

**EX-POST BENEFIT/COST ANALYSIS OF  
PROJECT No: 91/56, "GROW-OUT OF  
SOUTHERN BLUEFIN TUNA"**

**PREPARED FOR THE FRDC**

**By**



**November 1998**

## Non-technical Summary

This report describes the results of an ex-post benefit/cost analysis of an FRDC funded project “Grow-out of Southern Bluefin Tuna”, implemented in 1991.

The need for the project resulted from a decline in the southern bluefin tuna (SBT) stock and catches in the early 1980s, and a subsequent restructuring of the industry. Lower catches, combined with heavy debt incurred in the industry restructuring process resulted in many of the larger South Australian tuna fishing companies being placed in receivership in the late 1980s. These firms realised that if they were to survive they would have to stop supplying SBT to canneries and pursue a value adding strategy, focused on the production of sashimi grade tuna for airfreight to Japan.

As part of this value adding strategy, the Australian Tuna Boat Owners Association (ATBOA), in collaboration with the Overseas Fishery Cooperation Foundation of Japan and the Japan Tuna Federation, carried out feasibility studies on SBT farming. The results of these studies were positive. In response to a request from ABTOA, FRDC partially funded the next phase of the research, which focused on the “grow out” of SBT under commercial conditions.

The research project covered aspects of the capture of wild SBT, their onboard transport to the farm site, grow-out in cages, harvesting and test marketing and environmental monitoring. The main findings of the project were as follows:

- Purse seining and subsequent towing of large pontoons (containing the catch of SBT) to the farms were the preferred methods of capture and transport. These methods led to higher survival rates, compared to fish caught by poling and stored onboard. This was because the fish tended to be larger sized and were less prone to injury and stress during capture and transport due to the lack of direct handling.
- For the first 30-45 days after transfer to farms, feed consumption was low and the fish experienced a 25% weight loss. Thereafter, average weight gain was 0.3-1.0 kg per month in winter, increasing to 2.5–3.5 kg per month in summer. It was concluded that to take advantage of higher growth rates, early summer capture of SBT was desirable.
- Demand for pilchards for use as SBT feed resulted in the development of a pilchard fishery based in Port Lincoln. Catches rose from 145 tonnes in 1991/2 to over 3,500 tonnes by 1996/97.
- The quality of farmed SBT was assessed by 81% of Japanese experts to be either good or very good. There were no responses of poor or very poor.

- With regard to environmental impact, the farms had a pronounced, but localised, effect on the seafloor and benthic community and a relatively minor localised effect on the water column.

The total research cost of the project was just under \$1.6 million, of which FRDC contributed 14% (\$220,336). The benefits of the project can be divided into two areas. First, is the profit earned by SBT farm operators and the wages paid to labour employed on the farms, provided that labour would have otherwise been unemployed. The second comprise the profits earned in the South Australian pilchard fishery and the payments to the crews of pilchard vessels.

SBT farm profits were estimated to have increased from \$75,000 in 1991 to nearly \$64 million in 1998<sup>1</sup>, associated with an output of 5,100 tonnes. Farm employment grew substantially from 144 in 1994/5 to 240 in 1996/97. Unemployment statistics show that the average duration of unemployment is 27 weeks in South Australia. Therefore, wages paid to labour for the first 27 weeks of their employment were counted as economic benefits. From 1991 to 1998, total wages paid to farm labour is estimated at \$39 million<sup>2</sup>, of which around \$5.8 million is assessed to represent economic benefits.

The development of tuna farms was, in turn, responsible for the development of the South Australian pilchard fishery. The total net economic benefits derived from the pilchard fishery to date are estimated at between \$1 million and \$3 million per year<sup>3</sup>. With the increase in the TAC to 11,500 tonnes in 1998, the potential net economic benefits from the fishery are likely to treble.

Estimation of the net economic benefits of the project is based on annual costs and benefits of the project over the period 1990-1998. This is a highly conservative approach as it does not recognise the probable continuation of a positive net benefit stream well beyond 1998.

The project is estimated to have delivered net economic benefits of over \$107 million between 1991 and 1998. This is equivalent to a discounted net present value of \$55 million (using a 10% discount rate). The net present value of total research expenditures is \$1.3 million. Given that approximately 14% (\$0.2 million) of the research effort was funded by FRDC, 14% of the discounted net benefits (\$7.9 million) are also attributable to FRDC. This is equivalent to a benefit cost ratio of 41: 1.

---

<sup>1</sup> Data based on Morison (1997), An Economic Impact of Aquaculture and Fishing Industry Activity on the Eyre Peninsula Region of South Australia.

<sup>2</sup> op cit.

<sup>3</sup> Based on estimates of valued added and household income associated with the pilchard fishery by Morison (1997).

Discussions with industry representatives indicate that FRDC involvement in the project was pivotal in convincing the Overseas Fishery Cooperation Foundation of Japan to provide the bulk of the funding and expertise to the project – without which the SBT farming industry would not have gotten off the ground.

**EX-POST BENEFIT/COST ANALYSIS OF PROJECT NO: 91/56**  
**“GROW-OUT OF SOUTHERN BLUEFIN TUNA”**

**Research Agency: Tuna Boat Owners Association of Australia**

**FRDC program: Industry development**

### **1. Research Objectives**

- To assess the feasibility of capturing live SBT in a state from which they can survive under agistment conditions.
- To grow-out SBT in pontoons in the Port Lincoln area to assess: growth rates, total and in specific periods, feed conversion ratios and preferred feeds.
- To assess the influence of the SBT grow-out on the environment with water quality testing by the SA Government.
- To assess the quality and market acceptance of farmed SBT.
- To provide an example for other pontoon culturing or farming in Australia.
- To examine the possibility of breeding SBT.
- To provide a basis for sustainable biological research (eg. otoliths).

### **2. Background**

The introduction of ITQs in the SBT fishery in 1984, and the concomitant 30 per cent reduction in the size of the Australian TAC (from 21,000 tonnes to 14,500 tonnes), led to a rapid restructuring of the fleet with South Australian operators purchasing quota from Western Australian and New South Wales based fishers. Because of large acquisitions of quota, the South Australian industry became heavily in debt and had difficulty servicing its loans, a situation exacerbated by a further reduction in the TAC in 1986 (to 11,500 tonnes) and in 1988 (to 6,250 tonnes). As a result, many of the larger tuna fishing

companies were placed in receivership or under the direct control of banks. The industry realised that it would have to change from producing relatively low unit value products (from \$800 to \$2,000 per tonne), based on small sized SBT, for canning or export to Japan for frozen sashimi.

In 1990, a value adding strategy was developed by the Australian Tuna Boat Owners Association (ATBOA), "The Road to a High Value Added Tuna Industry", which had three aims: to develop longlining, in close cooperation with Japan; to develop SBT farms to produce fish for air-freighting to the Japanese sashimi market, and then diversification into further processing; and, to maintain a balance in the use of the quota between longlining, farming and other uses (such as poling) to reduce financial risk.

A central plank of the strategy was implemented through the establishment, by the ATBOA and Japanese industry association, of a joint venture arrangement under which Australian quota was leased to the joint venture. As well as providing cash flow to the Australian industry, the conditions of the joint venture agreement included training of Australian crew in longlining and the provision of experienced Japanese personnel to conduct experimental farming of SBT.

Assistance in the development of SBT farming was provided initially by the Overseas Fishery Cooperation Foundation of Japan (OFCF), with support from the Japan Tuna Federation. The South Australian Government supported the project by undertaking a range of environmental planning processes, such as the development of a management plan for Boston Bay, and through the provision of skilled personnel to advise on aspects of farm establishment and operation. The Commonwealth Government provided indirect support in the form of grants under the environmental research scheme administered by the Australian Fisheries Service. Feasibility studies carried out by the OFCF in 1990, involving the capture of SBT by poling, their transport to farms in the live holding tanks aboard SBT vessels and subsequent grow-out, proved successful, indicating the technical feasibility of SBT farming.

Following completion of feasibility studies in 1991, the OFCF was reluctant to become further involved in farm development, particularly as there was little apparent Australian

Government commitment to the project at that time (B. Jeffriess, pers. comm.) Without OFCF support, the continuation of the project would have been unlikely, particularly as the Australian industry was still in a difficult financial position, with two of the largest companies on the brink of insolvency.

Following the success of the feasibility studies, additional research was needed to develop commercial scale SBT farming and to assess the impact of the farms on their environment. In addition to the need for new research, Commonwealth Government financial support for the farming project was important to inspire OFCF confidence for their continued participation. These two factors led the ATBOA, in 1991, to apply for funding from the FRDC for a project (ie the project under review) with the objectives as outlined above to be undertaken at an experimental research farm in Boston Bay, near Port Lincoln.

### **3. Research Findings**

The research project was wide ranging, covering aspects of the capture of wild SBT, their onboard transport to the farm site, grow-out in cages, harvesting and test marketing, and environmental monitoring. The research findings are discussed under the headings of “capture and transport”, “grow-out”, “marketing” and “environmental monitoring”.

#### ***Capture and transport***

During 1991 and 1992, fish were caught using poling and stored in live holding tanks onboard the catcher vessels. An 88 per cent survival rate was attained during onboard storage in 1991, dropping to 83 per cent in 1992 due to an inadequate pumping system. The fish were held for up to 10 hours in the tanks during the trip from the fishing grounds in the Great Australian Bight to Boston Bay. There was little difference in the survival rates of large and small SBT.

Since 1993, the techniques of SBT capture and transport have changed radically. Poling was replaced by purse seining, and onboard storage was replaced by the use of a large pontoon in which the SBT are towed to the farms. Purse seine catches tended to be larger

sized fish which, because of the lack of direct handling, are less prone to injury and stress during capture and transport. Survival rates increased significantly.

### *Grow-out*

In 1991 and 1992 transfer of SBT from the catcher vessels to the farm pontoons resulted in high mortalities. Over this period, initial mortalities (within the first 45 days of stocking) ranged from 26 per cent to over 50 per cent mainly as a result of the extensive handling of the fish.

For the first 30-45 days after transfer, feed consumption was low and the fish experienced a weight loss of up to 25 per cent. Thereafter, their weights rose sharply. Within a year, the SBT had more than doubled their original weight. The average weight gain was measured as 0.3-1.0 kg per month in winter, increasing to 2.5-3.5 kg per month in summer. This suggested that early summer capture of the SBT would be desirable to take advantage of the higher summer growth rates.

Food conversion rates varied substantially between pontoons mainly as a result of initial over-feeding. By mid-1993, the feed conversion ratio had improved to around 15:1. Stocking density varied between 9.9 cubic metres per fish to 13.6 cubic metres per fish with little variation in fish quality between the pontoons<sup>4</sup>. Research on the effect of net fouling revealed that the level of dissolved oxygen in the pontoon was reduced by only 2 per cent by fouling organisms.

The SBT are generally fed on pilchards. These are obtained both from within Australia and from overseas. Demand for pilchards from the farms resulted in the development of a pilchard fishery based in Port Lincoln, catches from which grew from 145 tonnes in 1991-92 to over 3,500 tonnes by 1996-97. The TAC for the South Australian pilchard fishery has recently been increased to 11,500 tonnes.

---

<sup>4</sup> A condition on the licence permitting the operation of the farm specified that the stocking density must be within the range 2.5-4kg per cubic metre.



### ***Marketing***

Between August 1991 and May 1993, seven meat quality analyses were carried out on a farmed SBT and compared with two wild samples. Tests for moisture and protein content, lipid levels, carbohydrates and for freshness were carried out by the Japan Frozen Foods Inspection Service. A questionnaire based survey was also carried out on a range of experts in Japan. The quality of the farmed SBT was assessed by 81 per cent of the experts to be either good or very good, with no responses of poor or very poor.

In 1992, sales prices in Japan for air-freight, fresh SBT averaged around \$37/kg. Prices in subsequent years fell to around \$30/kg as the volume of production increased.

### ***Environmental monitoring***

The effect of the farms on the seafloor and benthic fauna and flora was monitored using sediment collectors, underwater photography, observations by divers and sediment samples. In general, the farms had a pronounced but localised effect on the seafloor and benthic community, and a relatively minor localised effect on the water column.

## 4. Benefit/Cost Analysis<sup>5</sup>

**FRDC expenditure:** \$220,336

**Total research cost:** \$1,592,336

In simple terms, to undertake the benefit/cost analysis, we need to estimate all economic benefits that flow from the research findings. Benefits are then compared to the financial cost of research, plus any economic costs that are required to capture the benefits.

### 4.1 Costs

The research results described above were obtained via an integrated package of research investments. Research commenced in 1990 with the implementation by the OFCF of feasibility studies on SBT farming. The costs of these pilot studies are unavailable. In 1991, the ABTOA gained Commonwealth Government support for the development of SBT farming through two grants, amounting to \$152,000, made under the "Environment Grants Scheme" administered by the Australian Fisheries Service. The OFCF subsequently invested \$1.2m, in 1992-93, in a joint project with the FRDC. The FRDC investment in 1991-92 and 1992-93 amounted to \$220,336. The total known research investment between 1990 and 1993 amounted to nearly \$1.6 million.

---

<sup>5</sup> There are two major components of net economic benefit in benefit/cost analysis - producer's surplus and consumer's surplus. Producer's surplus is a measure of net economic benefits created in the harvesting and processing sector from a specific research project. Although somewhat of a simplified explanation, producer's surplus can be thought of as additional profits generated. As well, if the research findings induce increases in production and employment, then to the extent that previously unemployed labour is employed, the associated wages would also be included as a benefit in producer's surplus.

Consumer's surplus is a measure of net economic benefits to consumers. For example, if a research project induces an increase in production and that in turn results in a decline in prices on the domestic market, then domestic consumers would be better off. Consumer surplus is simply a measure of this improvement in consumer well-being.

In an effort to keep technical jargon to a minimum, economic benefits are discussed in terms of increased profits, wages and other familiar concepts. As well, consumer's surplus is not particularly relevant to this study - because of the export-oriented nature of the SBT enterprises any possible gains in consumers surplus are not obtained by Australians.

Substantial costs were incurred in the commercialisation of SBT farming by the SBT farm operators. These are accounted for implicitly through calculation of the net benefits of the farms in the following section.

#### ***4.2 Research benefits***

Because the research applicant, ABTOA, represented the SBT quota holders and farmers, useful research results were quickly transferred and adopted in the development and commercialisation of the SBT farms. Many of the initial fish capture, transport, farm management and marketing practices were altered during the course of the project or shortly thereafter as a result of information gained from the research. In short, the research activities were well integrated with the commercial operations of the tuna farms.

There are two streams of direct net benefits attributable to the research. One is the profit earned by SBT farm operators and wages paid to labour employed on the farms<sup>6</sup>. The second comprises the profits earned in the South Australian pilchard fishery and the payments to the crews of pilchard vessels. Because a number of ancillary industries and service sectors have developed around the needs of the tuna farms<sup>7</sup>, it is likely that there are additional economic benefits generated in these sectors that are attributable to the research. These are not quantified in this study.

#### ***Farm profits and wages***

An economic impact study by Morison (1997), entitled “The Economic Impact of Aquaculture and Fishing Industry Activity on the Eyre Peninsula Region of South Australia”, provides estimates for 1994-95 and 1996-97 of “value added” and household income generated from the tuna farms and the associated pilchard fishery. From these estimates, SBT farm and pilchard fishery profits and wages can be derived for these years.

---

<sup>6</sup> Other minor components of “value added” not included in the benefit analysis are direct and indirect taxes, subsidies, interest and depreciation.

<sup>7</sup> Service industries that have developed include diving services for net cleaning, provision of tuna feed and feed storage facilities, and freight forwarding.

The relationships between SBT farm output, profits and wages for 1994-95 and 1996-97 were assumed to be relevant for other years for which value added data was unavailable.

Because the amount of SBT that can be caught by domestic vessels is limited by the TAC, diversion of increased quantities of purse seine caught fish to the farms results in lower availability of SBT quota for capture by longline and poling vessels for export to the Japanese sashimi market. Although there are some distributional changes in profits and wages, the same tonnage of SBT is being caught and sold from the wild fishery. In the estimates of farm profits, allowance is made for catcher vessels to be paid the same wharf price for tuna transferred to farms as that paid for fresh tuna sold to the fresh sashimi market. Hence, no allowance for any reduction in profits and wages for the tuna catching sector is necessary.

Profits are estimated to increase from \$75,000 in 1991 to nearly \$64 million in 1998, associated with an output of 5,100 tonnes. Rapid growth of production and profits was experienced until 1996 when a severe storm resulted in high tuna mortalities in the farms. As a result, losses of around \$22 million were incurred that year. Production and profits recovered quickly in 1997, reaching a level of around \$63 million in 1998. Farm production is expected to increase in 1999 to over 6,700 tonnes (pers. comm. Brian Jeffriess), but profits are expected to fall slightly as a result of lower SBT prices.

The wages paid to farm labour represent economic benefits, provided the labour would have been otherwise unemployed. If, on the other hand, there is a high demand for labour, and individuals can expect to get alternative jobs at similar wage rates to those paid by the SBT farms, then the wages paid to farm labour are not counted as benefits. Clearly, the true situation is somewhere between these extremes.

Australian Bureau of Statistics labour force data for 1998 in South Australia indicates that the average unemployment rate is around 10 per cent with an average duration of unemployment of 27 weeks. This suggests that the wages paid to labour for the first 27 weeks of their employment should be counted as economic benefits. This duration of unemployment is assumed to have applied throughout the 1990's.

Gross wages are taken from the data collected in Morison (1997) for the years 1994-95 and 1996-97, and a relationship between farm output and wages estimated and applied to other years. The number of people employed grew substantially from 144 in 1994-95 to 240 in 1996-97. Labour costs over the same period increased from around \$3.4 million to \$7.2 million. From 1991 to 1998, total wages paid to farm labour is estimated at \$39 million, of which around \$5.8 million is assessed to represent economic benefits.

***Pilchard fishery profits and wages***

The development of the tuna farms is said to be responsible for the development of the South Australian pilchard fishery. Therefore the net benefits flowing from the pilchard fishery are attributable also to the research which led to the establishment of the tuna farms. The fishery, which got under way in 1991, has produced around 3,500 tonnes per year over the period 1995-97, and the TAC has recently been increased to 11,500 tonnes for 1998.

Morison (1997) estimates the value added and household income generated by the pilchard fishery for the years 1994-95 and 1996-97. These figures are used in the same way as those for the tuna farms to derive estimates of pilchard fishery profits, payments to labour and economic benefits from labour (see Table 1). The total net economic benefits derived from the pilchard fishery to date are estimated at between \$1 million and \$3 million per year. With the increase of the TAC to 11,500 tonnes, the potential net economic benefits from the fishery are also set to treble.

*Table 1: Estimated costs and benefits of research project "SBT Grow-out"*

	1991	1992	1993	1994	1995	1996	1997	1998	Total
<b>Research costs</b>									
FRDC investment	113,216	107,120							220,336
Other research costs	152,000	1,220,000							1,372,000
<b>Total research costs</b>	<b>265,216</b>	<b>1,327,120</b>							<b>1,592,336</b>
<b>SBT farm output</b>	20	150	850	1,600	2,700	1,700	4,400	5,100	16,520
Value added rate \$/tonne	3,793	3,793	3,793	3,793	3,793	0 <sup>a</sup>	6,041	12,500	
Farm profits	75,852	568,889	3,223,704	6,068,148	10,241,100	-22,813,000	26,580,400	63,750,000	87,695,093
Farm labour rate (\$/t)	2,133	2,133	2,133	2,133	2,133	2,182	2,182	2,182	
Total labour cost	42,667	320,000	1,813,333	3,413,333	5,760,000	7,200,000	9,600,000	11,127,273	39,276,606
Adjusted farm net labour benefits	22,154	144,000	775,385	830,769	1,218,462	747,692	1,246,154	793,007	5,777,622
Total tuna farm direct benefits	98,006	712,889	3,999,088	6,898,917	11,459,562	-22,065,308	27,826,554	64,543,007	93,472,715
<b>Pilchard output</b>	145	1,230	2,377	2,803	3,708	3,428	3,500	11,500	28,691
Value added (profit) rate	389	389	389	389	389	389	389	389	
Total pilchard profit	56,405	478,470	924,653	1,090,000	1,442,412	1,333,492	1,361,500	4,473,500	11,160,432
Labour cost	66,732	566,072	1,093,946	1,290,000	1,706,500	1,577,638	1,610,774	5,292,544	13,204,206
Adjusted net labour benefits	34,649	259,273	274,088	101,797	216,260	0	17,205	1,911,688	2,814,961
Total pilchard net benefits	91,054	737,743	1,198,741	1,191,797	1,658,672	1,333,492	1,378,705	6,385,188	13,975,393
<b>Total net benefit of SBT farms and pilchard fishery</b>	<b>189,060</b>	<b>1,450,632</b>	<b>5,197,830</b>	<b>8,090,715</b>	<b>13,118,233</b>	<b>-20,731,816</b>	<b>29,205,259</b>	<b>70,928,195</b>	<b>107,448,108</b>

a) In 1996, a severe storm caused large-scale SBT mortalities in the farms, resulting in substantial losses being incurred.

### ***4.3 Net benefits<sup>8</sup>***

In estimating the total net economic benefits of the project, annual costs and net benefits from the years 1990 to 1998 are included. This is a highly conservative approach, as it does not recognise the probable continuation beyond 1998 of a positive net benefit stream from the project.

The project is estimated to have delivered net economic benefits totaling over \$107 million up to 1998 (see Table 1). This is equivalent to a discounted net present value of \$55 million<sup>9</sup>. The corresponding net present value of total research expenditures is \$1.3 million.

Discussions with Brian Jeffriess of the ATBOA indicate that FRDC's formal involvement in the project was extremely important in getting the project off the ground. OFCF, the major funding agency, having financed the successful feasibility studies in 1990, was reluctant to commit any more funds toward the further development of SBT farming unless there was continued and explicit Australian Government support for the project. In the absence of FRDC involvement at that time, it was suggested that the OFCF would have pulled out of the project. Without OFCF funding and expertise, and considering the dire financial circumstances of the Australian industry, further development of the SBT farms would certainly have stalled. For how long is uncertain, but discussions with ATBOA suggest that several SBT operators, who subsequently turned out to be the main innovators in developing the farm sector, would have been bankrupted.

In calculating the net economic benefits of FRDC's investment, it is assumed that in the absence of the entire research project, the tuna farming industry would not have developed. In this case, the financial contribution to research by all parties was necessary

---

<sup>8</sup> While subsequent research projects have been carried out, and are currently being undertaken, such as the research on the development of "pelletised" food and a project by OFCF on breeding SBT in captivity, the results of these projects are yet to be implemented. Therefore, all the benefits identified above as flowing from the tuna farms and from the development of the pilchard fishery, are attributable to the original research investments by FRDC, OFCF and the Australian Fisheries Service.

<sup>9</sup> Using a discount rate of 10%.

to the current state of development of farming. In this situation, the net benefits are allocated to each of the research-funding parties in proportion to their funding contribution.

Therefore, given that approximately 14 per cent of the research effort was funded by FRDC Project No. 91/56, 14 per cent of the discounted net benefits are attributable to the FRDC expenditure. As shown in Table 2, the returns to FRDC investment are estimated at \$7.9 million, equivalent to a benefit cost ratio of 41:1.

*Table 2: Summary of research costs and benefits*

<b>Research costs and benefits</b>	
Net present value of FRDC investment	\$0.2m
Discounted net benefits attributed to FRDC investment	\$7.9m
Benefit/Cost ratio	41:1

It is apparent that FRDC involvement in this project was highly beneficial in terms of research leverage, resulting in over \$1.2 million being invested by OFCF, and substantial net economic benefits being generated from the jointly sponsored project. OFCF are said to regard the SBT grow out project as one of the most successful that they have funded, and given the opportunity, would fund other ventures of this nature.



**"GROW-OUT OF  
SOUTHERN BLUEFIN TUNA  
(SBT)"**

**Tuna Boat Owners  
Association of Australia Inc.**

**FISHERIES  
RESEARCH &  
DEVELOPMENT  
CORPORATION**



**PROJECT No. 91/56**

## ***Acknowledgments***

This Report substantially draws on the data gathered and analysed by staff of the Overseas Fishery Cooperation Foundation (OFCF) of Japan. These staff, principally Takahiko Homano and Yoshio Koga, were funded totally by the OFCF, and worked with the Australian industry to make the FRDC Project such a success.

This Report also draws on information gathered and analysed by Mr Steven Clarke of the South Australian Research and Development Institute (SARDI). Mr Clarke's commitment and professional capacities accelerated the successful outcome of the Project, and have continued to contribute to the sustainability of tuna farming.

The Project was also underpinned by the contribution of the Port Lincoln tuna industry, most notably Ron Waller and Joe Puglisi who devoted many hours of unpaid personal work and equipment.

The Project would also not have been possible without the confidence and support of the Japan Tuna Federation, who initiated the farming concept in Australia as a contribution towards the optimum utilisation of the global SBT resource.

# Report on FRDC Project No. 91/56

## "Grow-Out of Southern Bluefin Tuna (SBT)"

(June 1991 - May 1993)

### Summary

1. Farm grow-out of SBT was the central plank in the high value added strategy adopted by the Australian tuna industry following the 67 per cent quota cut in the late 1980's. Though live capture and grow-out of larger SBT was generally not thought to be logistically and technically feasible, especially under Australian conditions, the Australian industry needed it to work if they were to survive.
2. The two year FRDC grant enabled the Tuna Boat Owners Association of Australia (ATBOA) to combine with the Overseas Fishery Cooperation Foundation (OFCF), a Japanese semi-government authority, in the experimental grow-out farm from 1991. The experiment followed detailed pilot studies on the feasibility of live capture and grow-out of SBT.
3. The experimental farm began in 1991 with two pontoons, fifteen tonnes of captured SBT and full participation of Japanese farm experts and Australian fishers. Over the next two years, the Project proved the physical feasibility of SBT farming. It also led to major engineering improvements by the industry which have made SBT farming financially viable. The work of the research farm has expanded considerably and remains the core research arm of the industry (eg pellet development).
4. SBT grow-out has grown as follows:

	<u>Input</u> <sup>(1)</sup> (Whole Tonnes)	<u>Production</u> <sup>(2)</sup> (Tonnes - gilled and gutted)	<u>Market Value</u> <sup>(2)</sup> (\$m)
1991	15	20	1
1992	138	150	5
1993	762	850	31
1994	1,497	1,600	48
1995	1,799	2,100	54
1996 <sup>(3)</sup>	3,274	1,700	50

(1) *Source:* Bureau of Resource Sciences except 1991 (ATBOA)

(2) *Source:* ATBOA

(3) Production reduced by major losses in April 1996 storm

5. Tuna farming has also led to major spin-off benefits for fisheries and communities on Eyre Peninsula. These include.

- (1) A demonstration effect for other holding/grow-out (eg. rock lobster is now being grown out).
  - (2) Creation of a new feed fishery (eg. pilchards).
  - (3) Creation of a farm research structure focusing on tuna nutrition, environmental monitoring and fish health, as well as the wider aquaculture research to be conducted in the new Lincoln Marine Science Centre.
  - (4) Initiation of a project to attempt to spawn SBT on the research farm.
  - (5) Creation of an independently estimated 993 direct and indirect jobs on Eyre Peninsula (*Econsearch, 1997* ).
  - (6) Farming has become a domestic and international tourist attraction.
  - (7) Farming has created a major refrigerated transport infrastructure to Adelaide and the Eastern States for other fisheries and industries to utilise.
6. This Report fulfils the requirements of the FRDC grant. It outlines:
- (1) The technical details of the farm innovations
  - (2) The developments in live fish capture
  - (3) The grow-out experience
  - (4) Harvesting and test marketing.
  - (5) Environmental issues
  - (6) Summary of technical and other developments subsequent to the end of the FRDC grant.
7. Please note that the Report does go into some detail on developments since the end of the Project funding (ie. mid-1993), so that the Project's importance can be put in a wider perspective.

ATBOA

## Background to the Project

### The Southern Bluefin Tuna (SBT) Fishery

1. SBT or *Thunnus maccoyii* (castelnaui) - (see *Figure One* ) is a highly migratory species ranging from the Western South Africa to New Zealand (see *Figure Three* ). It is almost certainly a single stock - with the only known spawning ground being south of Java in the Indian Ocean (see *Figure Two* ). The fish is now thought to live up to 45 years (CSIRO, 1996 ), and is known to reach up to 200kgs.
2. The slow-growing and late first spawning age of SBT (thought to be about 9 years) makes the fish vulnerable to over-fishing. Its very widespread geographical coverage also makes research very difficult and costly. The outcome is that, despite a large investment in research by Japan and Australia, scientists still often disagree on the actual stock situation.
3. SBT is fished largely by Australia, Japan and New Zealand who are the three Members of the international body managing the fishery under the Convention for the Conservation of SBT (CCSBT). The Commission meets annually to consider recommendations from its Scientific Sub-Committee, and to set quotas. These quotas, operating since 1984, were substantially cut in the late 1980's as follows:

#### Tonnes Per Annum (Australian Quota Years)

	<b>1987/88</b>	<b>1988/89</b>	<b>1989/90 to current</b>
Japan	19,500	8,800	6,065
Australia	14,500	6,250	5,265
New Zealand	1,000	450	420
	35,000	15,500	11,750

However, since the mid-1990's, the SBT stock has become heavily fished on the High Seas by non-Members of the CCSBT, mainly Taiwan, Korea and Indonesia. In 1996 their total catch was around 4,000 tonnes.

4. Almost all SBT quota holders and fishers in Australia belong to the Tuna Boat Owners Association of Australia (ATBOA). The Members of ATBOA had borrowed heavily to rationalise the industry after the quotas were introduced in 1984. The initial 14,500 tonne Total Allowable Catch (TAC) was well below the catch levels of the early 1980's. The introduction of fully tradeable Individual Transferable Quotas (ITQ's) in 1984-85 resulted in major transfer of quota and catching from New South Wales and Western Australia to South Australia (ABARE, 1989 ). In 1997, over 85 per cent of the Australian quota was owned by Port Lincoln operators, and over 90 per cent of the Australian catch was under their control.

## FIGURES

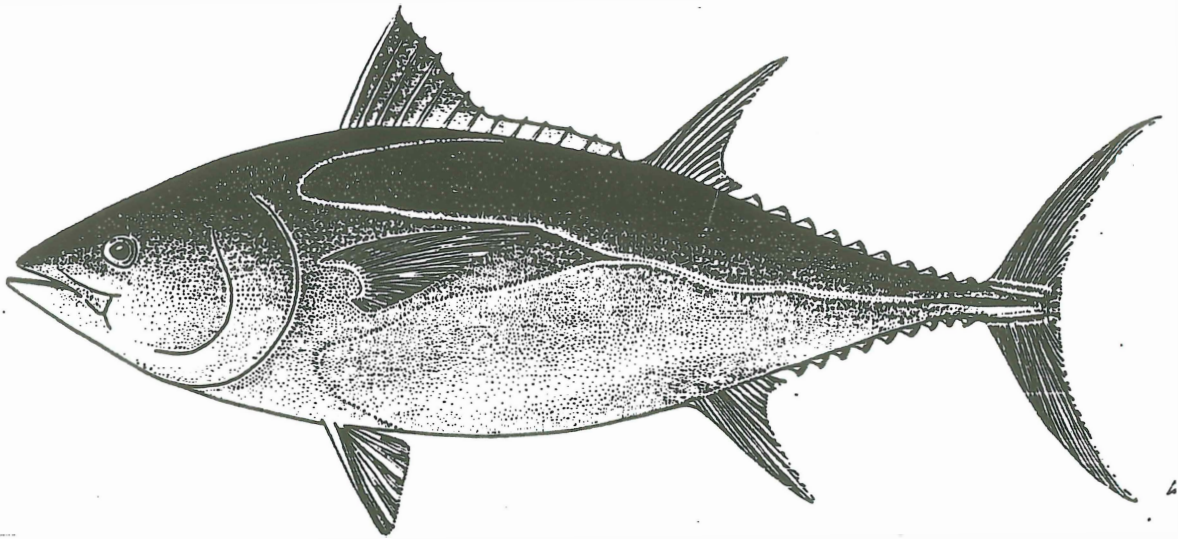

**Fig. 1.** Southern bluefin tuna, *Thunnus maccoyii* (Castelnou, 1872). (Line drawing courtesy FAO; from: FAO species catalogue, Vol. 2, Scombrids of the world; an annotated and illustrated catalogue of tunas, mackerels, bonitos and related species known to date, by B B Collette and C E Nauen, FAO Fisheries Synopsis No. 125)

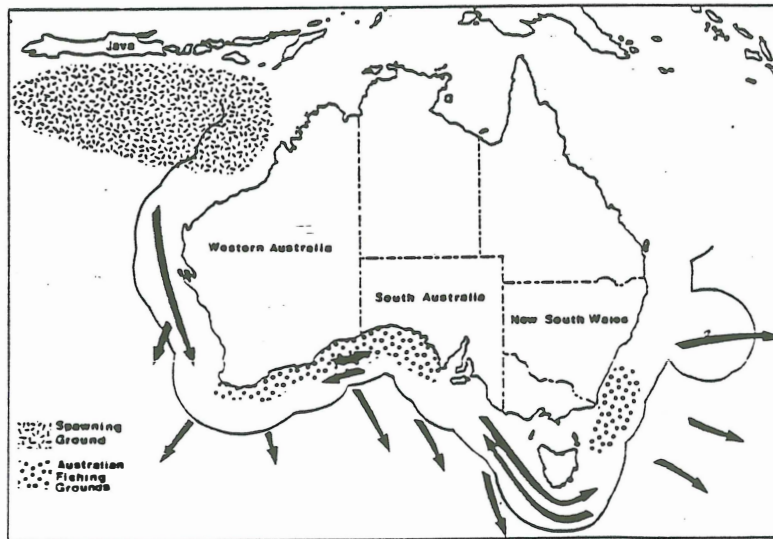

**Fig. 2.** SBT spawning ground and Australian SBT fishing grounds; arrows show dispersal through and from the Australian Fishing Zone. Source: Caton, 1991.

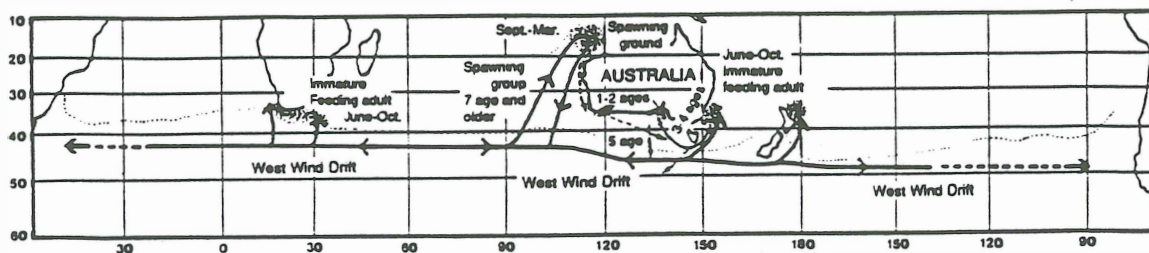

**Fig. 3** Schematic representation of the presumed migratory routes of southern bluefin tuna. Source: Caton, 1991.

5. The quota cuts in the late 1980's and the heavy debt overhang resulted in many substantial operators entering either receivership or bank control. To recover required a major re-adjustment in the Australian industry. Traditionally the industry had used SBT for either canning (\$1.30/kg) or small fish sashimi exports to Japan (\$4/kg). The industry needed to move to high value-added product to survive. The strategy - *"The Road to a High Value Added Tuna Industry"* was formally developed by the ATBOA in 1990 and has remained the core strategy of the industry since. It has three arms:
  - (1) The development of longlining, in close co-operation with Japan.
  - (2) Pioneering of farming of SBT for air freight export of whole fish to Japan initially, and then diversification into further processing .
  - (3) Maintaining a balance in use of the quota between longlining, farming and other uses (eg. poling), so reducing the financial risk.
6. For detailed information on the fishery and quota movements refer to:
  - (1) *"Individual Transferable Quotas and the Southern Bluefin Tuna Fishery"*, ABARE Occasional Paper No. 105, April 1989.
  - (2) *"Southern Bluefin Tuna - Scientific Background to the Debate"*, BRR Bulletin No. 3, January 1990.

### Tuna Farming Elsewhere

7. The Port Lincoln project was the first real attempt to farm SBT anywhere in the world, although it is understood that it was considered at Esperance in 1987 and at Albany in 1988. Elsewhere in the world:
  - (1) In Japan, Northern Bluefin Tuna (NBT), a sister species to SBT, is captured with high mortality at around 200gms, and then raised to around 8kgs in Southern Japan. They are then marketed or transported for accelerated fattening in warmer waters (eg. Okinawa).
  - (2) In North America, Europe and Northern Africa, Atlantic Bluefin is grown out. The fish is traditionally captured by netting off the bays after the fish have spawned, are in very lean condition, and swim into the bays. In 1995 and 1996 groups of Australian and Japanese transferred the Port Lincoln technology of capture by purse seine to farms in Spain and Croatia.
8. The techniques required for Port Lincoln, or anywhere in Australia, were totally different from that traditionally used in the rest of the world. The Australian industry, because quota is measured at the catching point, could not afford significant mortalities - and does not have access to post-spawning fish. Feed is also expensive in Australia. Fundamentally what was required was a farming system catching larger live fish, transporting them long distances with very low mortalities, and then achieving rapid weight gain. If the initial problems could be overcome it was always expected that the industry could later develop cheaper feed sources (eg. pellets), and higher volume catching methods.

9. As noted above, there was extreme doubt in Australia from scientists, managers and industry whether tuna farming could be financially and/or physically viable. The confidence that it was achievable was largely generated by Yuichiro Harada of Japan Tuna Federation (JTF) and Akira Suda of the Japan Sea Farming Association.

### **Partners in the Project**

10. After the ATBOA value-adding strategy was developed, ATBOA sought expertise from Japan on both farming and longlining. The result was that the farm experiment initially became a partnership between ATBOA and the Overseas Fishery Cooperation Foundation (OFCF) - an arm of the Government of Japan - with support from Japan Tuna Federation, the tuna industry group in Japan. The South Australian (SA) Government was initially only a tripartite nominal partner in the project, though it later was to become a very active participant through the SA Research and Development Institute (SARDI). The Commonwealth Government declined to become actively involved in the project although it became indirectly involved through the grants from the environmental research scheme and the Fishing Industry Research and Development Corporation (FIRDC).
11. OFCF's continuing participation in the project was dependent on active support from an Australian Government body. It became clear that the unwillingness of the Commonwealth and South Australian Governments to be actively involved was a threat to the project, as was the very difficult financial situation of the Australian industry. Without FIRDC's participation the project would not have continued.
12. FIRDC was initially reluctant to fund the project because of the widely held view that aquaculture requiring wet feed could not succeed in Australia because of the shortage of baitfish, and because of doubt over the experimental design of the Project (see Australian Fisheries). However, after exhaustive scrutiny, FIRDC agreed to provide funds for the project from July 1991, though at a much lower level than requested.
13. OFCF contributed two farming experts to the term of the OFCF project from January 1991 to May 1993. One Mr Takahiko Hamano was manager of an NBT farm in Japan and acknowledged as one of the world experts at the time in tuna farming. The other, Mr Yoshio Koga, came with wide experience in farming of other species. The total OFCF financial contribution over the 2.5 years of their participation was around \$1.5 million.
14. The Tripartite Agreement operated formally through a Project Management Committee (PMC) with overall responsibility for the Project. The PMC consisted of Members from the Australian industry, from OFCF and from the South Australian Government.



## Initial Developments

### Choosing the Location

15. In late 1989, ATBOA and OFCF developed a feasibility study outline, and on 14-31 January 1990, an OFCF/ATBOA/Japan Tuna team visited various alternative sites such as Albany, Esperance, Eden and Port Lincoln. The OFCF team was led by Dr Akira Suda, formerly Executive Director of the Japan Sea Farming Association. Their reports are in Attachments Two and Three.
16. Boston Bay, adjacent to Port Lincoln was chosen because of the proximity of schooling larger fish, the concentration of the Australian industry in Port Lincoln, and the engineering infrastructure in the area. Boston Bay itself is a north-south aligned bay situated on the south-western side of Eyre Peninsula (see *Figure Four*). It is approximately 15km long and 6km wide. Boston Island, owned locally, is 5km long and 2km wide, and situated in the middle of the Bay. The Research Farm, and most other farms until 1995, were sited on the western side of the Island. Channels at the northern and southern ends of the Island allow exchange between Boston Bay and Spencer Gulf, and the eastern and western sides of the Island. (*Note* : from 1996 farms increasingly moved east of Boston Island).
17. Winds for most of the year are gentle breezes (ie. less than 10 knots). Current data suggest that currents are strongly influenced by local wind and atmospheric effects. (For a detailed analysis of currents in the area, see *Noye, 1996*). Current speed is much slower inside the Bay (less than 2.5cm/s 75 per cent of the time), than in the southern channels (less than 12.5 cm/s 75 per cent of the time) (*Petrusevics in Bond 1993*). Flushing time in Boston Bay is around 9 days in winter and 24 days in summer (*Petrusevics in Bond 1993*). Boston Bay is well mixed during winter with salinities about 35 parts per thousand and water temperatures which range from 12°C to 23°C (*Bond 1993*).
18. Port Lincoln, although having a population of only 13,000 people, is the centre of a major fishing and rural production area. The ex-wharf value of seafood alone is around \$150 million, including tuna, prawns, rock lobster, abalone and other marine scale species such as snapper (*Econsearch, 1997*). Tuna and rock lobster grow-out, and abalone farming, are likely to underpin an aquaculture production of over \$200 million per annum by the end of the decade.
19. With the co-operation of Lincoln Cove Development Company Pty Ltd, a number of fish were captured by poling, and 35 were placed in the Dangerous Reef Platform. To show the evolution of the Project, a summary of the observations of these fish by the Australian catchers is in *Attachment One*. A Japanese expert (Tsugihiko Kobayashi from OFCF) attended and reported that the results of the experiment justified a full-scale pilot trial. After consideration of detailed reports and a further study mission (18 March to 3 April 1990), Port Lincoln was chosen because of:

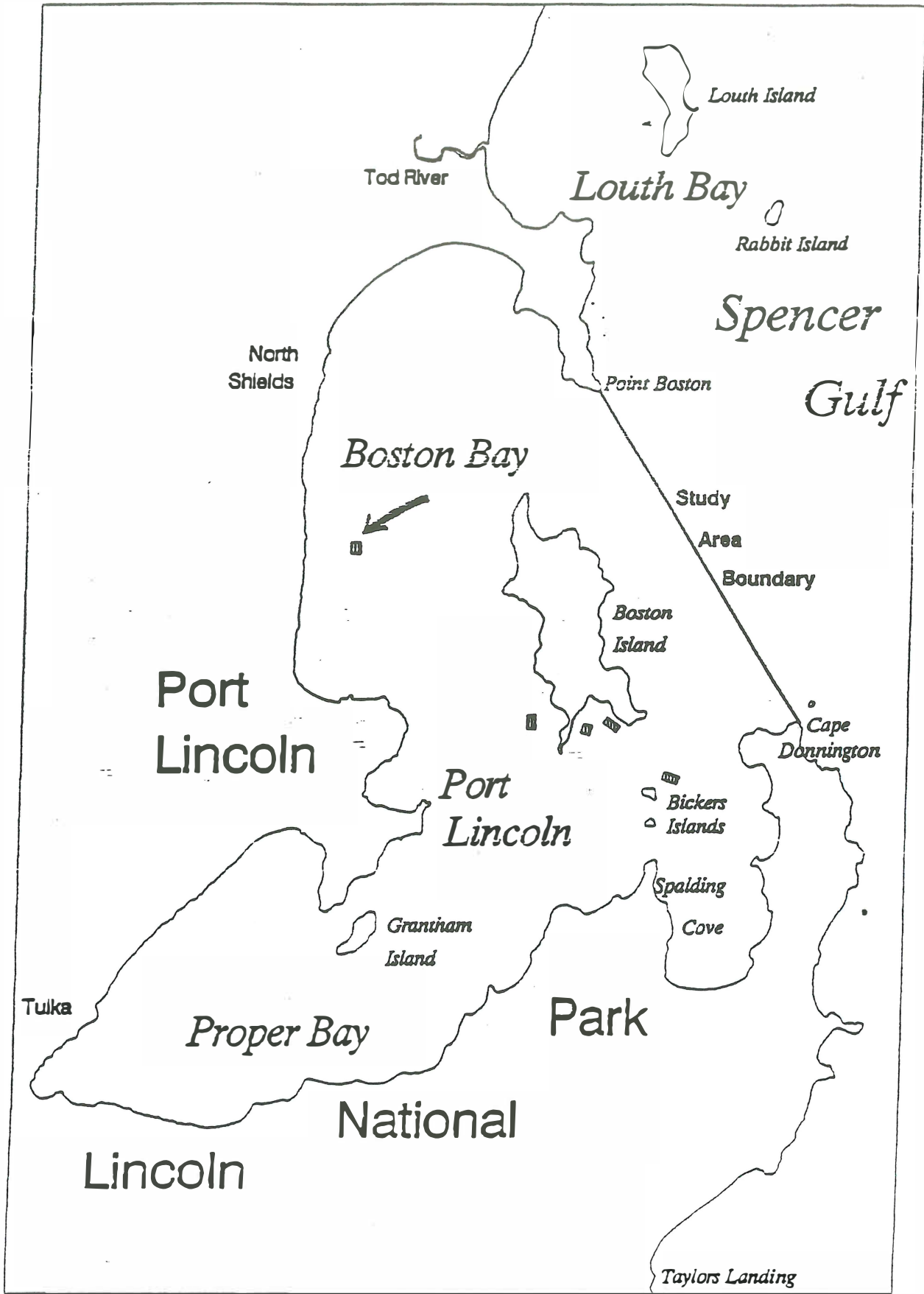

**Fig 4** Chart of implementation of the southern bluefin farming project in Boston Bay, Port Lincoln

- (1) The proximity of suitable fish for the experiment.
- (2) The infrastructure in Port Lincoln for catching and farming.

The Reports of the study missions are in Attachments Two and Three.

20. The actual location in Boston Bay (Port Lincoln) for the farm was chosen for its deeper water, current flow and proximity to infrastructure. The site was 6.25 hectares with a depth of 17 metres, and at 34° 04' 30" south and 135° 52' 02" east 1.4km offshore. On the site the pontoons were arranged on the NE-SW diagonal because of the heavy seas from the northwest in winter.
21. After extensive formal consultation with the SA Aquaculture Committee, a research and development licence was granted for the Project. On 6 November 1990 substantial conditions were placed on the use of the site - they are in *Attachment Four*.

### **Equipment Used**

22. **Pontoons:** After visiting Tasmania, the project group decided to use the polarcirkle pontoon design (see *Figure Five* ) used widely overseas and in the Tasmanian salmon industry. These contrast with the rectangular and lower specification pontoons used for farming tuna in Japan. The initial polarcirkle pontoons used were 30m diameter with a total flotation of 7.4 tonne less the weight of the unit, 2.62 tonnes. It was made of high density black polyethylene plastic (HDPE), of 280mm diameter pipe (30 metre lengths), with either plastic moulded or galvanised steel staunchions. They consisted of two concentric HDPE "pipes" (250-280mm in cross-section) that float on the water's surface and are held in place by the staunchions. A third pipe (100mm in cross-section) was held approximately one metre above the water's surface by the staunchions and provides a hand rail. The first two research pontoons in 1991 were supplied by Plastic Fabrications Pty Ltd. from Tasmania. These frames were \$31,430 each, made up in Port Lincoln. Later Global Systems Pty Ltd (Tasmania) and Sarriba Pty Ltd (Port Lincoln) have also supplied pontoons.
23. Note that this type of pontoon remains the favoured structure in tuna farming. Other configurations have been tried but only the Bridgestone Hi-Seas hexagonal pontoon is still being used (see *Figure Six* ). The latter is a highly specified unit designed for heavy duty towing from the catching grounds, and increasingly doubling up as a static pontoon. The Bridgestones can be extended to a larger cubic metre area by insertion of extra pipe. In 1992, the research farm did also experiment with a 25 metre square single pipe pontoon, similar to those used in Japan. This was not successful for the reasons that the fish did not adjust to the cornered design, and because of swell pressure on the joints.
24. The pontoons are moored (see *Figure Seven* ) either individually (greater than one pontoon diameter apart) using up to 16 large anchors (eg. rail lines) per pontoon, or in a few recent cases, moored together in a group (two or four) using large cement mooring blocks. The first research pontoons each had four single fluke anchors of 250kg each (see *Figure Eight* ). Floats 8 x 200L Black 14kg's were purchased from Plastic Fabrications. Details of the mooring and setting the anchors are included in Figures Nine, Ten and Eleven.

Fig. 5. Polarcirkle pontoon design

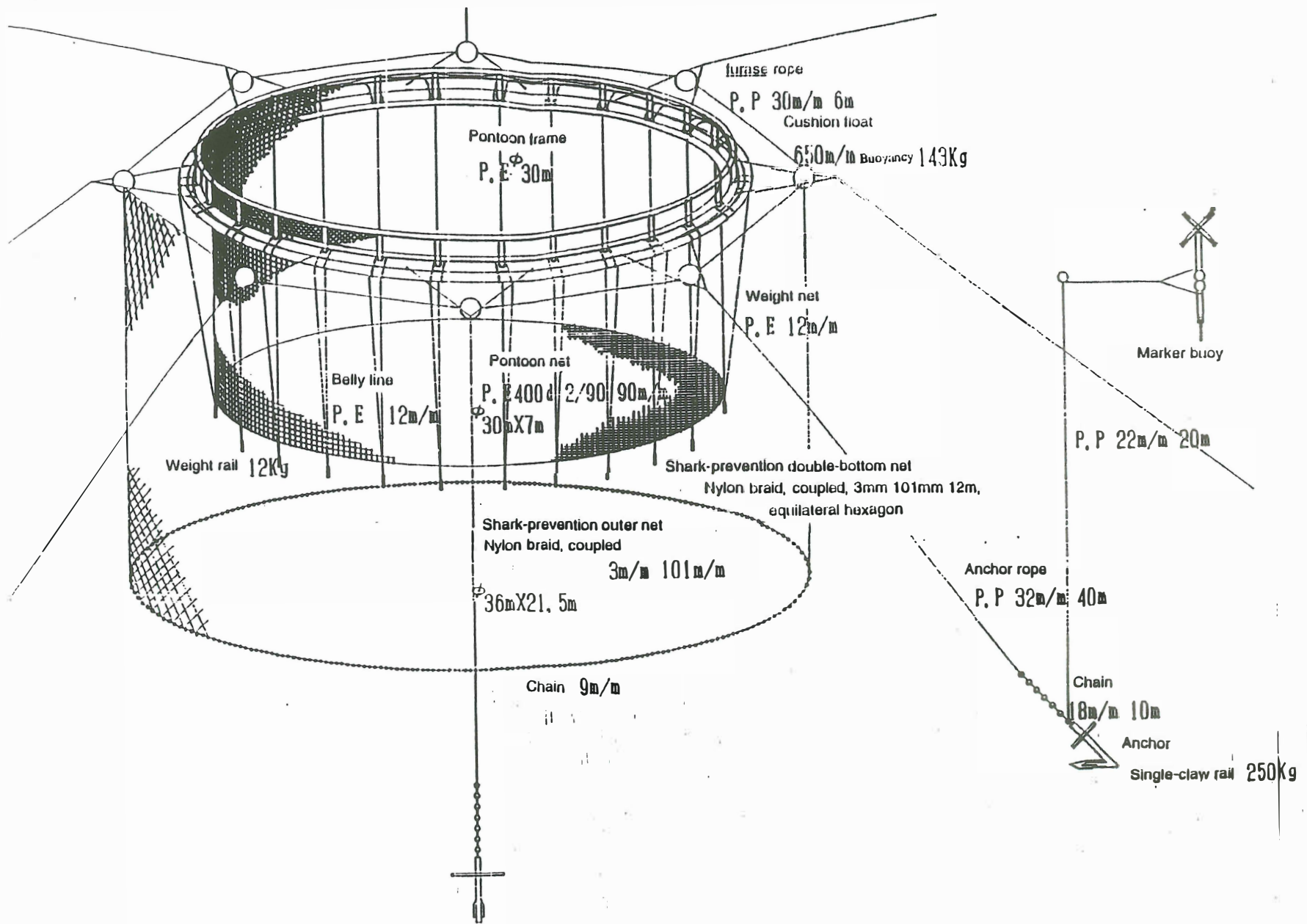

Fig. 6. Bridgestone Hi-Seas hexagonal pontoon

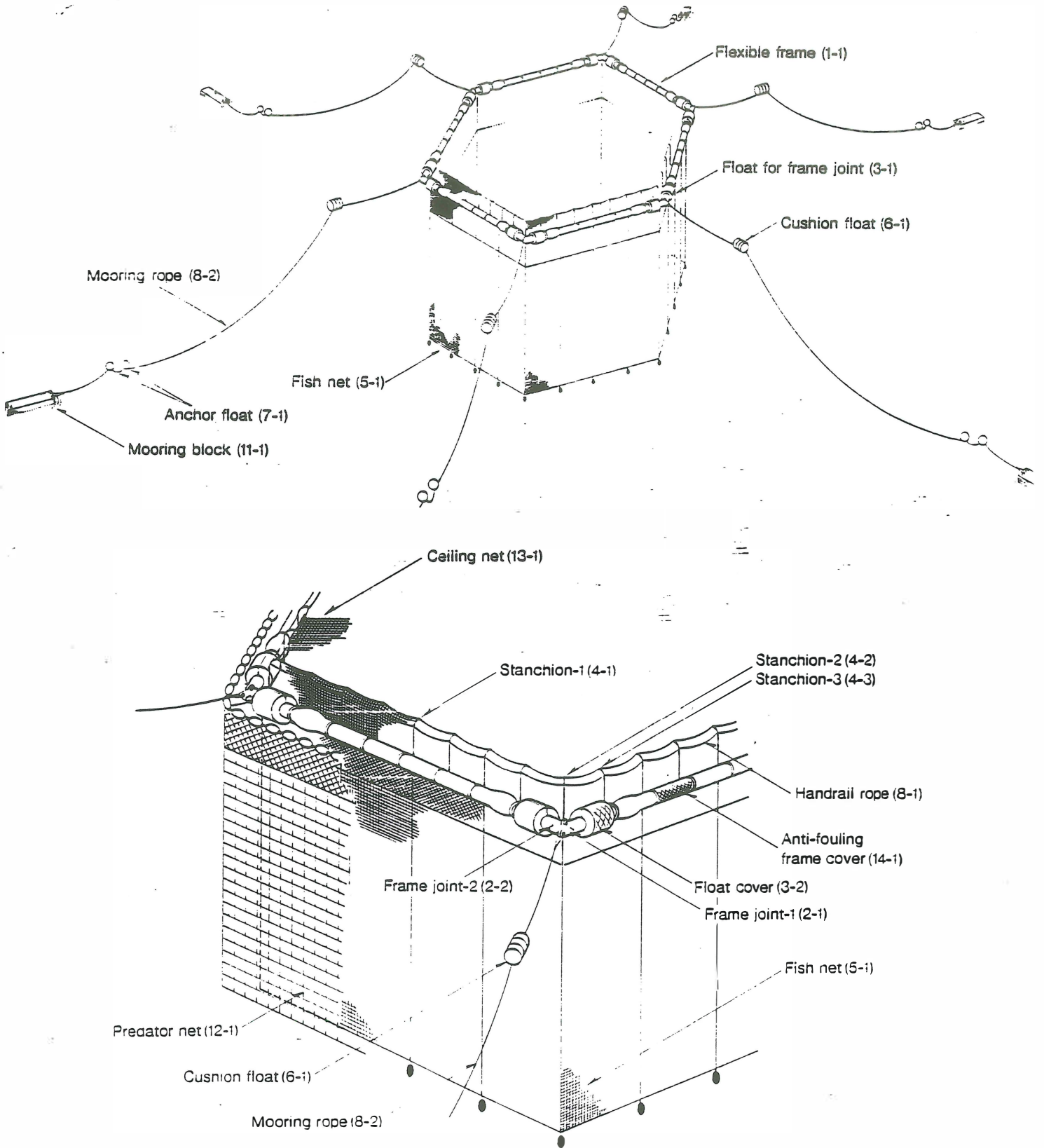

Fig. 7 Towing and temporary mooring of pontoon frames

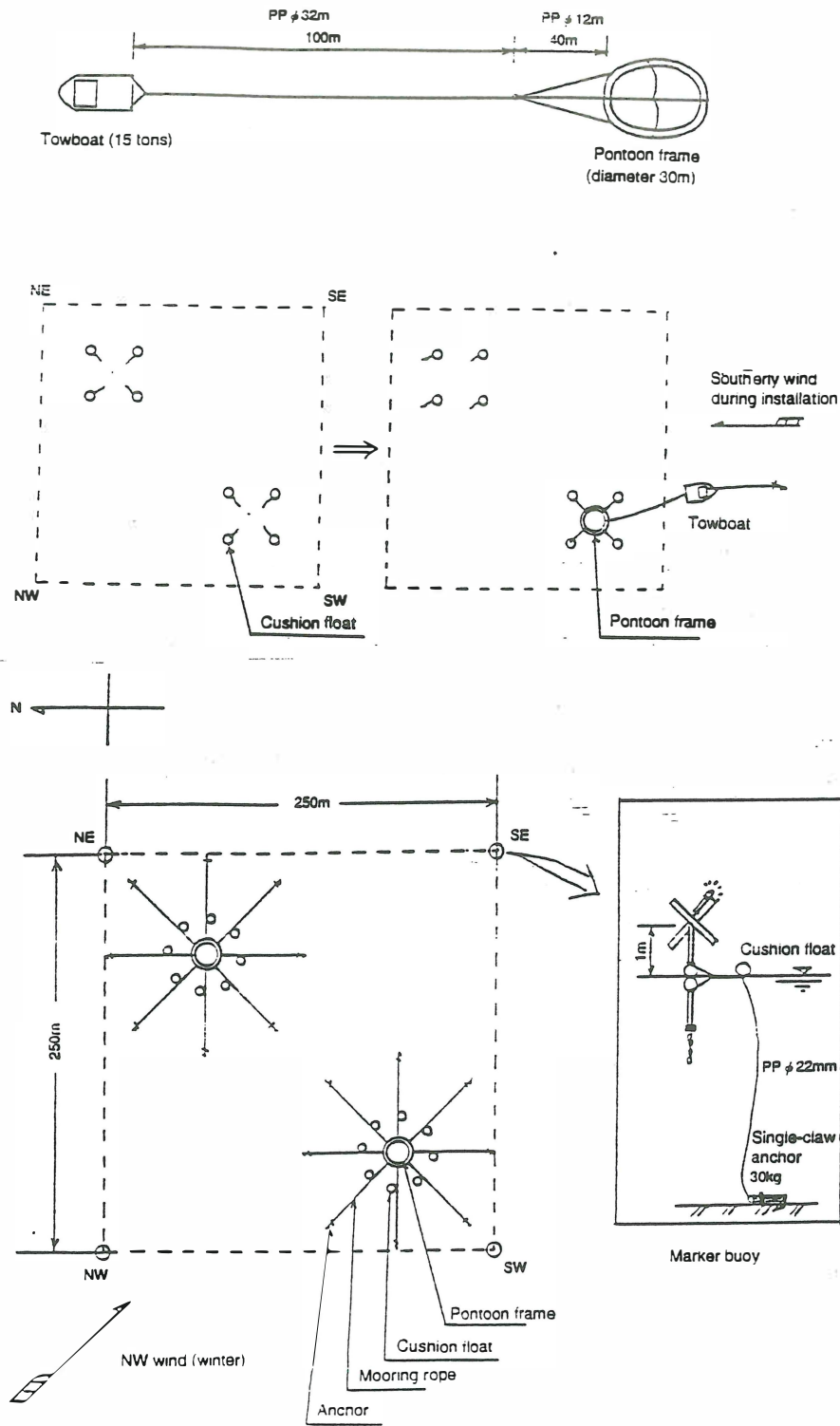
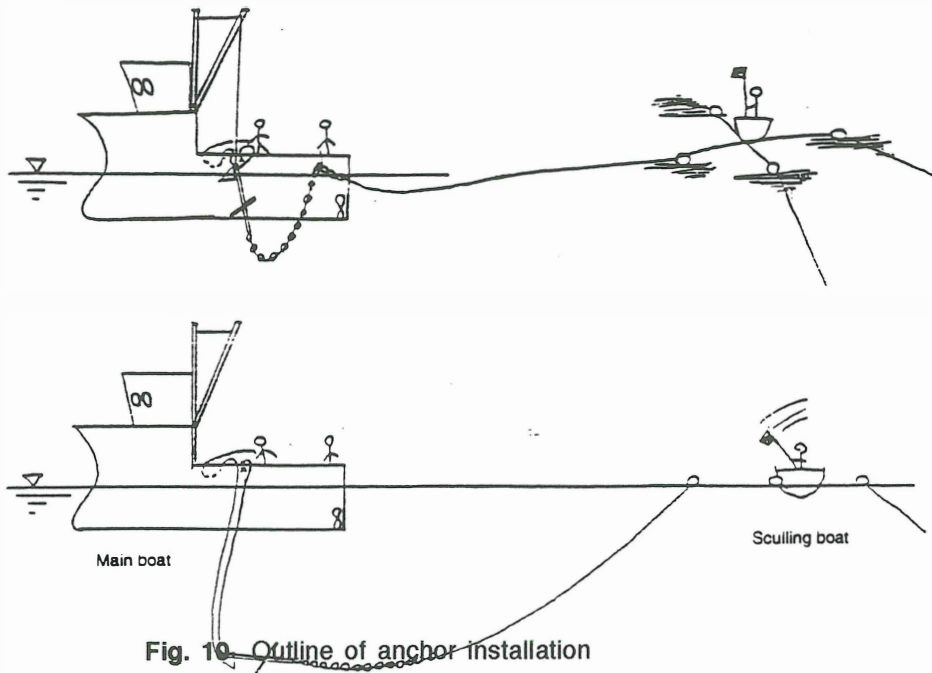
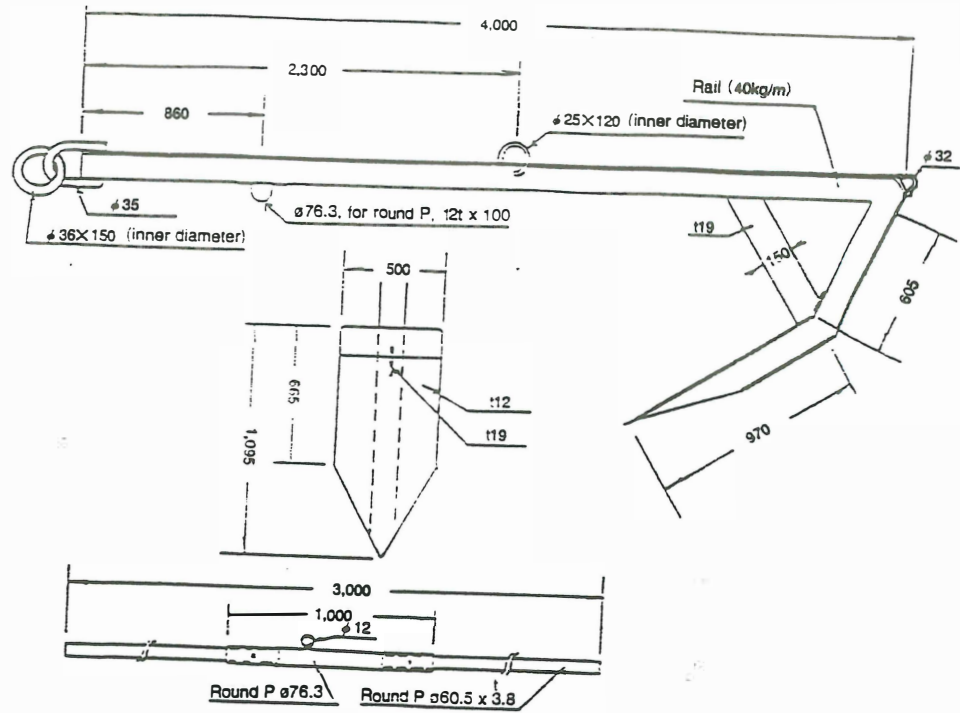

Fig. 8 Arrangement of farming pontoons on the lease area

**Fig. 9** Steel anchor, single-claw, 250kg (unit: mm)



**Fig. 10** Outline of anchor installation

**Explanation**

- The main boat holds the anchor over its broadside
- Instructions for direction and distance are relayed from the sculling boat to the main boat
- The main boat lowers the anchor and waits in anchor-suspended condition
- On a signal from the sculling boat to cast anchor, the anchor is dropped

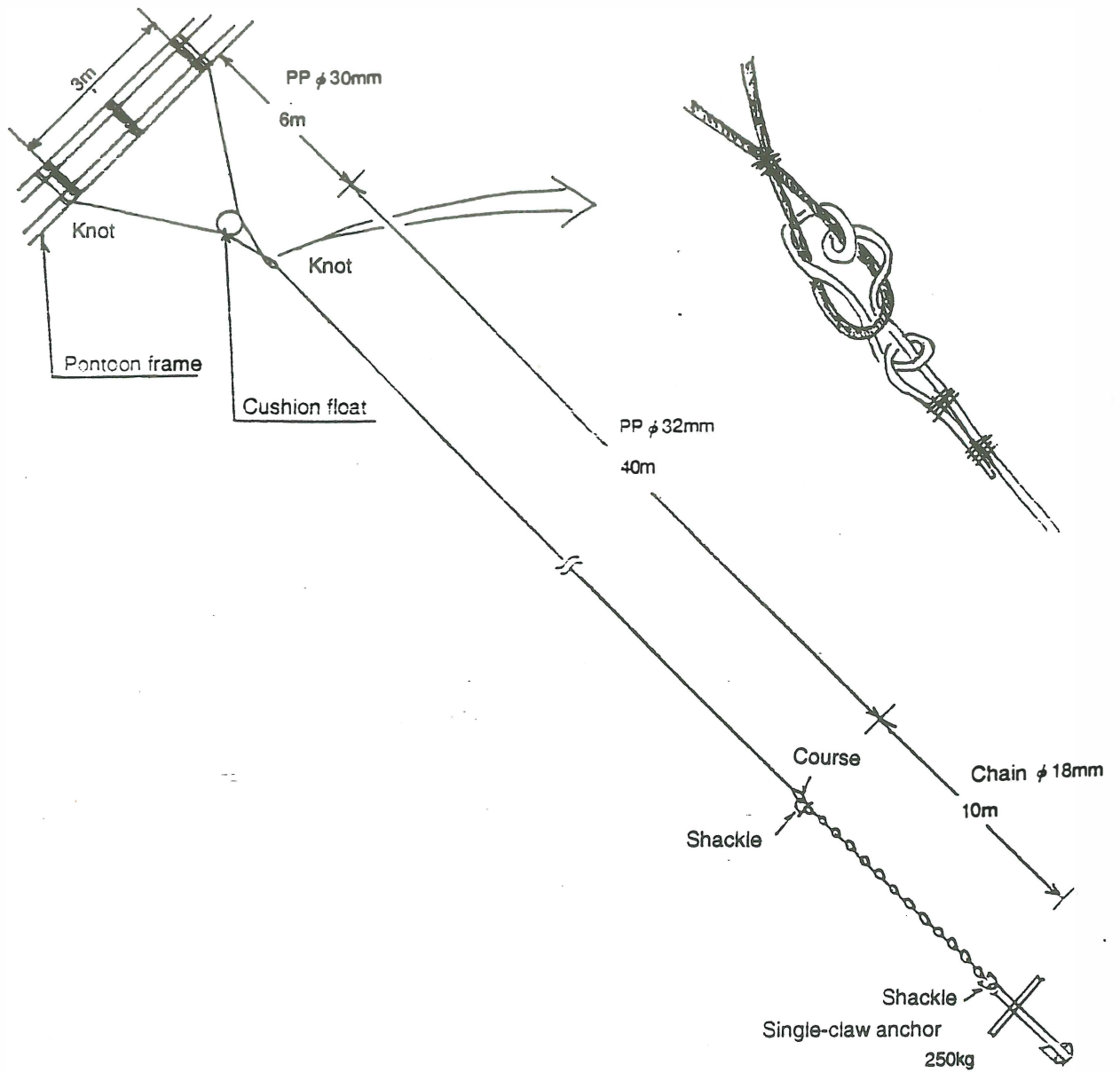

Fig. 11 Specifications of mooring rope



25. The first research farm nets were imported from Japan in quarters - made of black 100 per cent polyethylene 400d, 2/90, 90mm mesh, 30m x 7m. These were imported in 4 panels per net with an fob price of ¥3,275,000 per net. Two nets were suspended from the floating pontoons. The inner net, which contained the fish, ranged from 60mm to 90mm mesh. Outer predator nets ranged from 150mm to 200mm mesh. The inner nets had a side drop of seven to ten metres, and the bottom of the net was designed to be at least five metres from the bottom. The predator net falls straight to the sea floor with a bottom chain. One other option recently tried is a predator net supported by a large submerged mid-water frame which holds both the predator net and inner net in place. Yet another option allowed under the Management Plan for the industry, is pegging both nets to the bottom, but no one has yet tried it. Assembly of the inner net and joining to the pontoons are outlined in Figures Twelve, Thirteen, Fourteen and Fifteen.
26. For any given depth of net, the volume available for rearing fish in a 40 metre diameter pontoon is approximately 56 per cent greater than for a 32 metre pontoon. In general, the larger the structure, the more cost-effective production will be. What larger pontoons also allow is lower stocking rates and less diving for a specific tonnage of fish. The only limits on pontoon size appear to be:
- (1) Net changing, though if more nets are changed in situ (as in Tasmania) this will be less a problem.
  - (2) The very large risk exposure in one pontoon, for fish health and weather reasons.
27. Examples of comparative net volumes are:

<u>Diameter of Pontoon</u> (m.)	<u>Net Depth</u> (m.)	<u>Water Volume</u> (Cubic m.)
32	12	9,651
40	12	15,080
45	12	19,085
50	12	23,561

28. The predator nets (see *Figures Sixteen and Seventeen* ) were trialed from the first days of the research project. The initial predator net was second-hand, black, nylon plaited and knotted purse seine net, with 3mm diameter knots, and 101mm mesh, 300 G/106m, 132m long and 20m deep, with a frame rope of 16mm diameter polypropylene. A zinc plated 9mm chain was fitted to the face on the sea floor, with the net separated from the pontoon by about 3m, and draped in a curtain fashion from the cushion floors attached to the anchors. Three to four weights from a tuna longliner were fitted between the eight cushion floats. The same netting was used to create a double thickness floor. This was replaced in May 1991 by a net from Netcraft Pty Ltd (Tasmania) - of green polyethylene, 6ins x 5mm braid, , 20m (H) and 110m (L) (Cost, delivered to Port, \$10,946).

Fig. 12 Assembling the pontoon nets

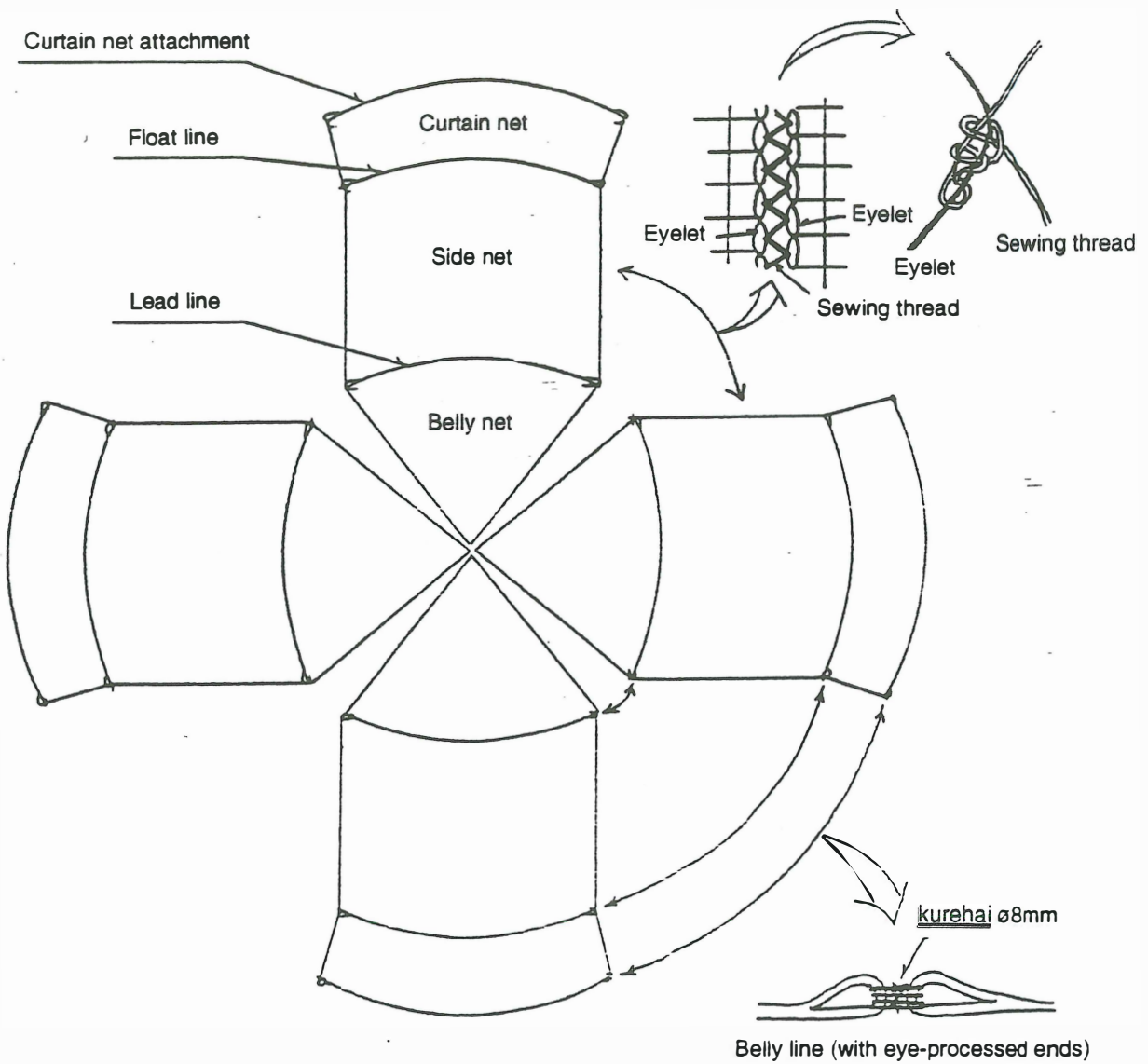

Fig. 13 Jointing the towable pontoon and main pontoon nets

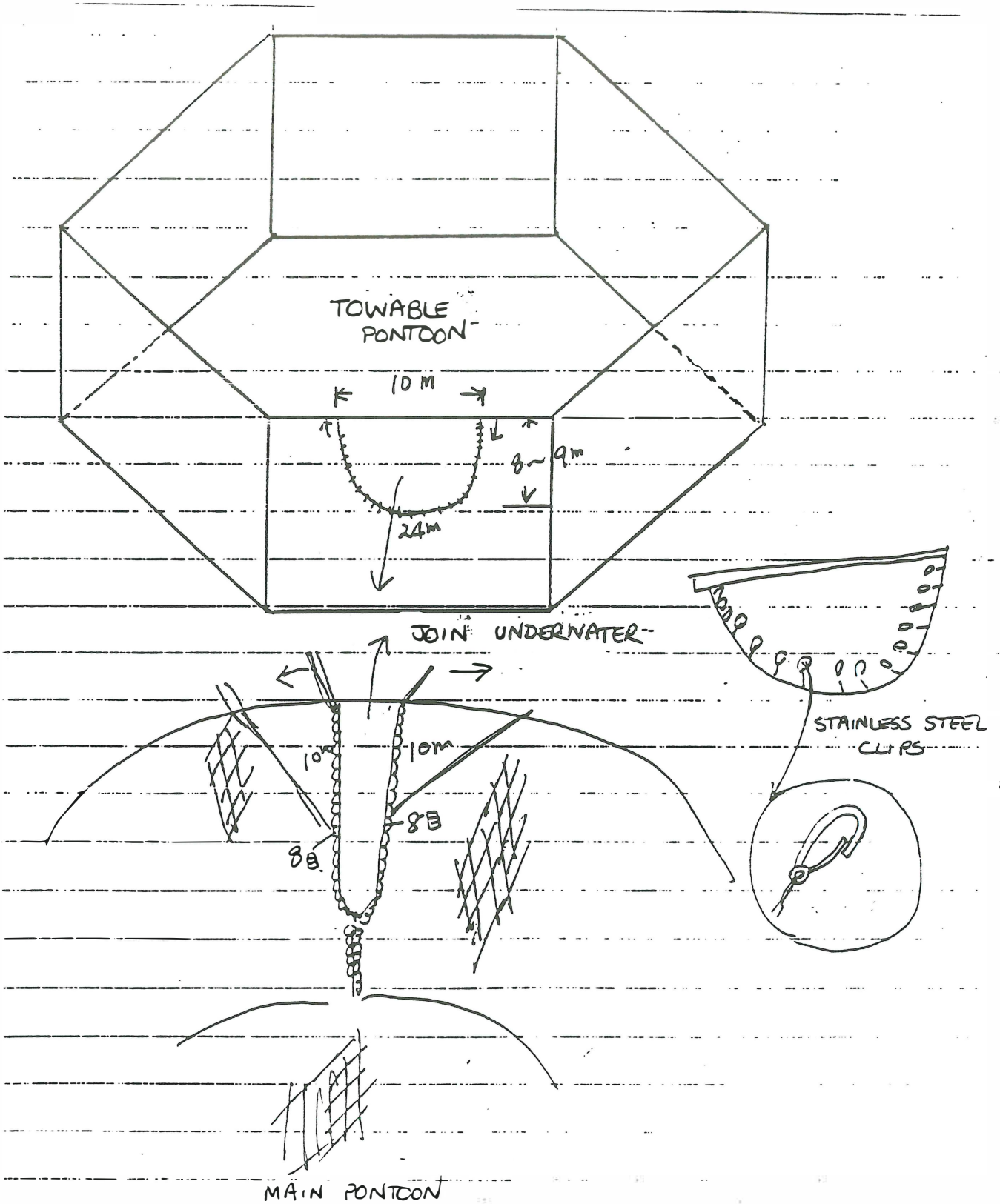

Fig. 14 Fitting the net

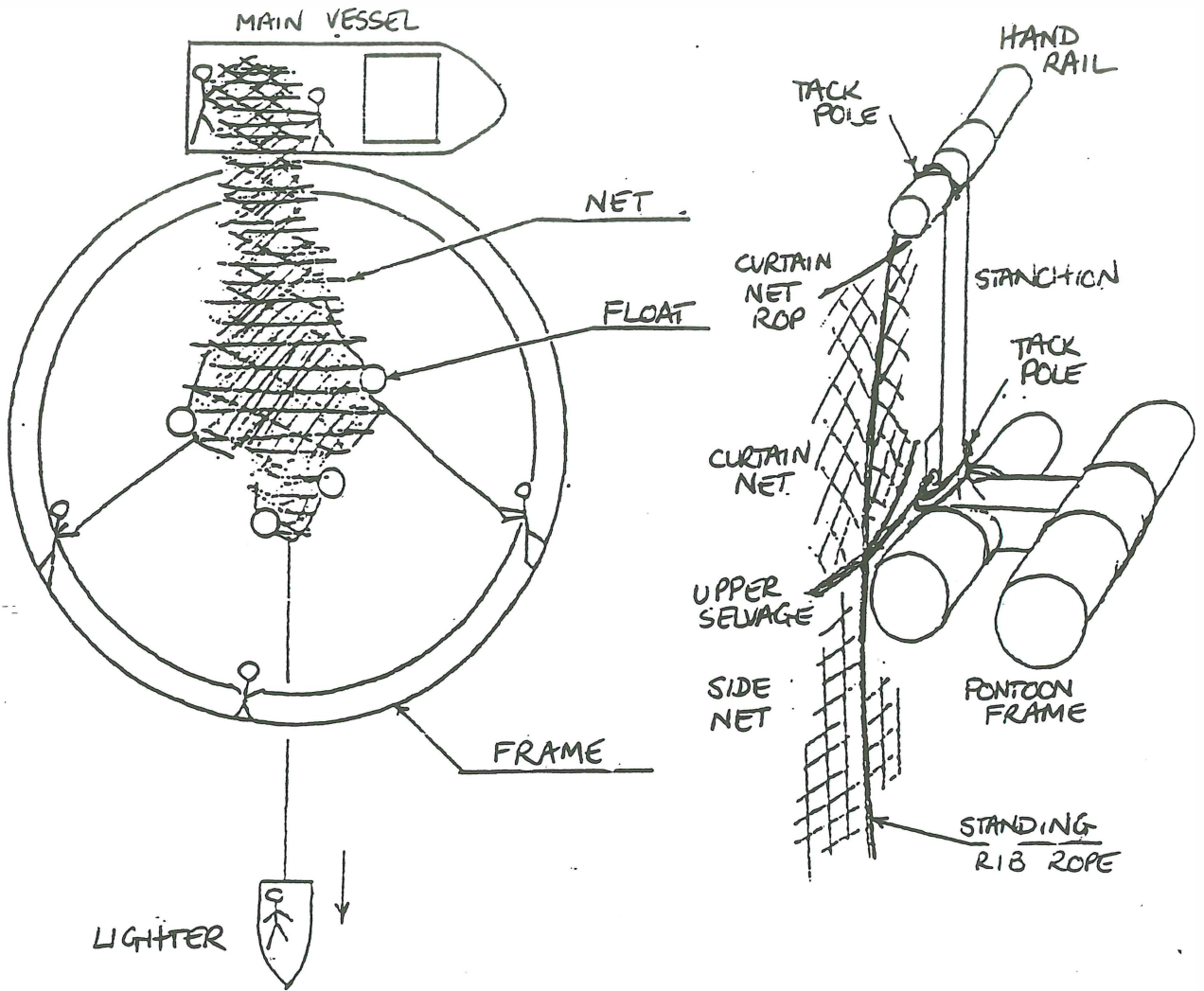
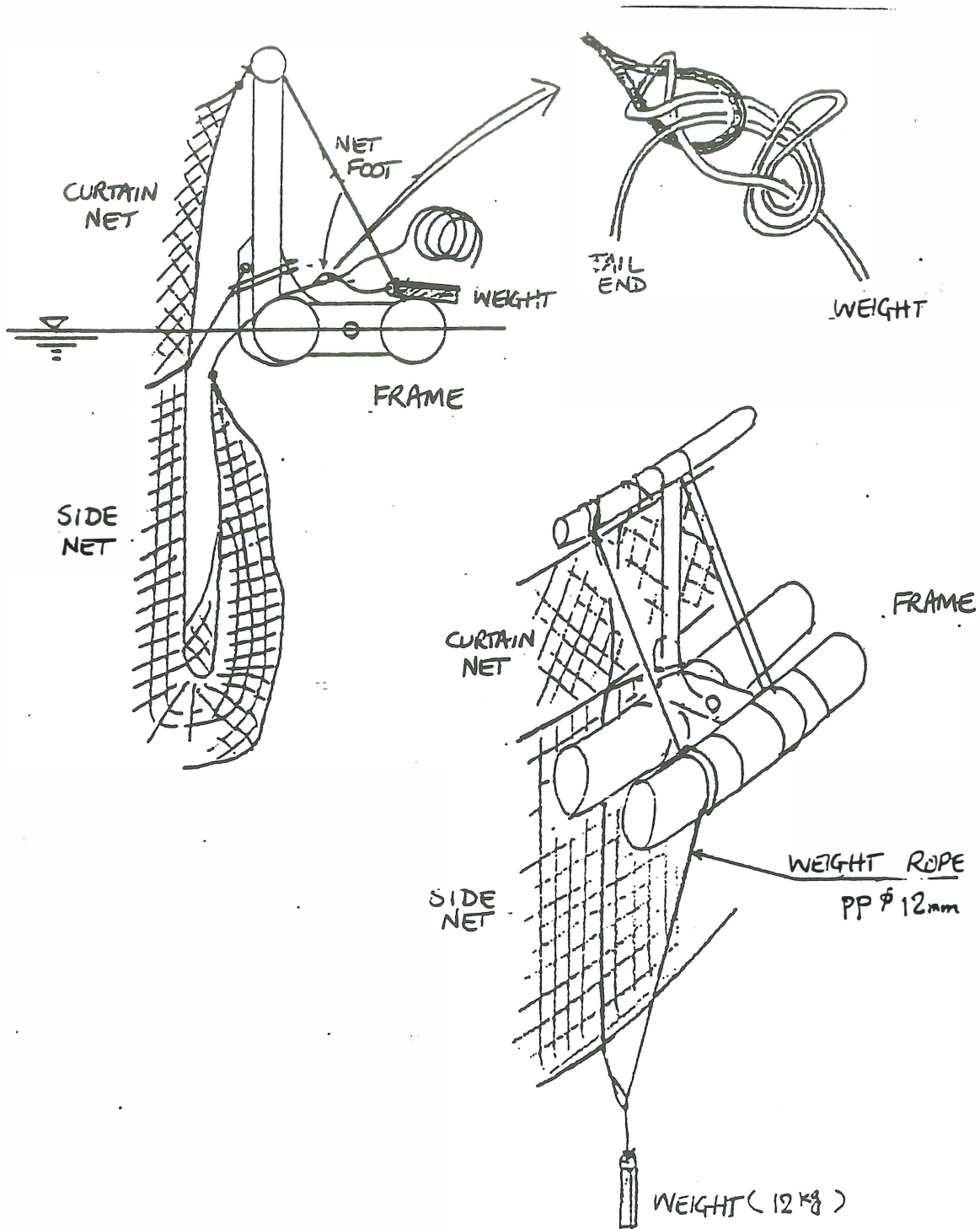

Fig. 15 Fixing weights to the net foot

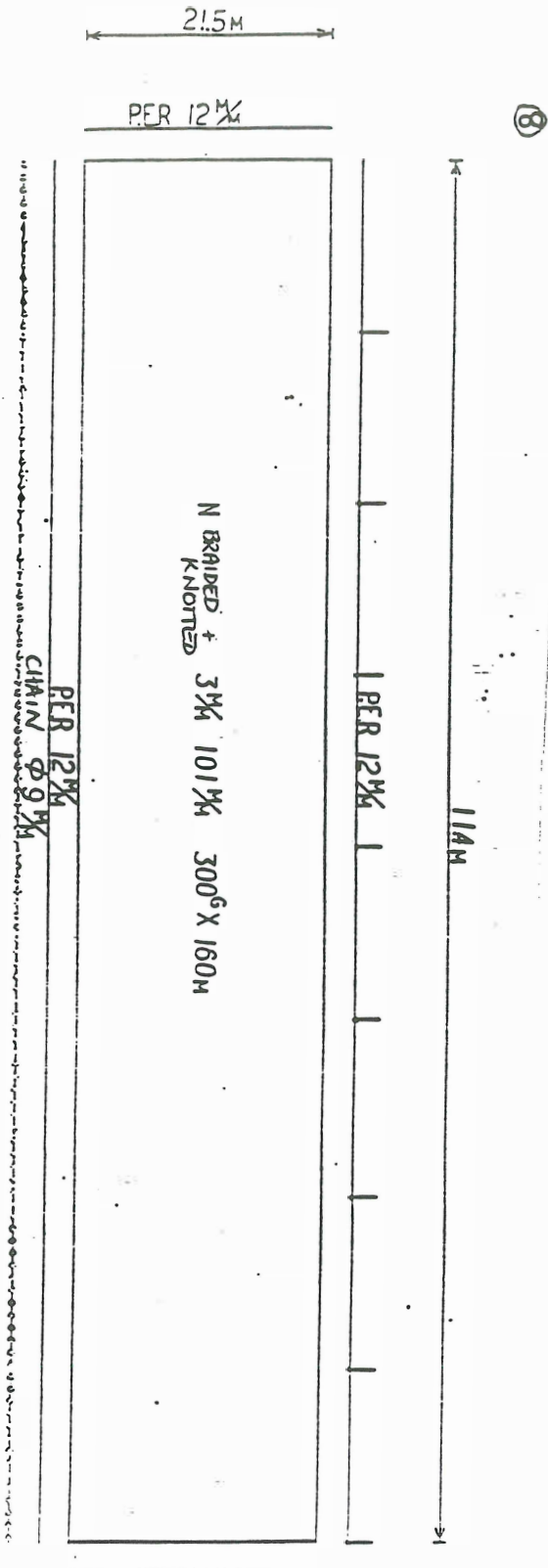

**Fig. 16** External sharkproof net  
(36m  $\phi$  x 21.5m)

28 February 1991

9mm  $\phi$  chain

Braided and knotted net  
3mm, 101, 300mm, 300G x 160m



**Fig. 17** Double thickness sharkproof bottom net (12m side, octagonal)

Braided and knotted net 3mm, 101mm, 400G x 40.4m

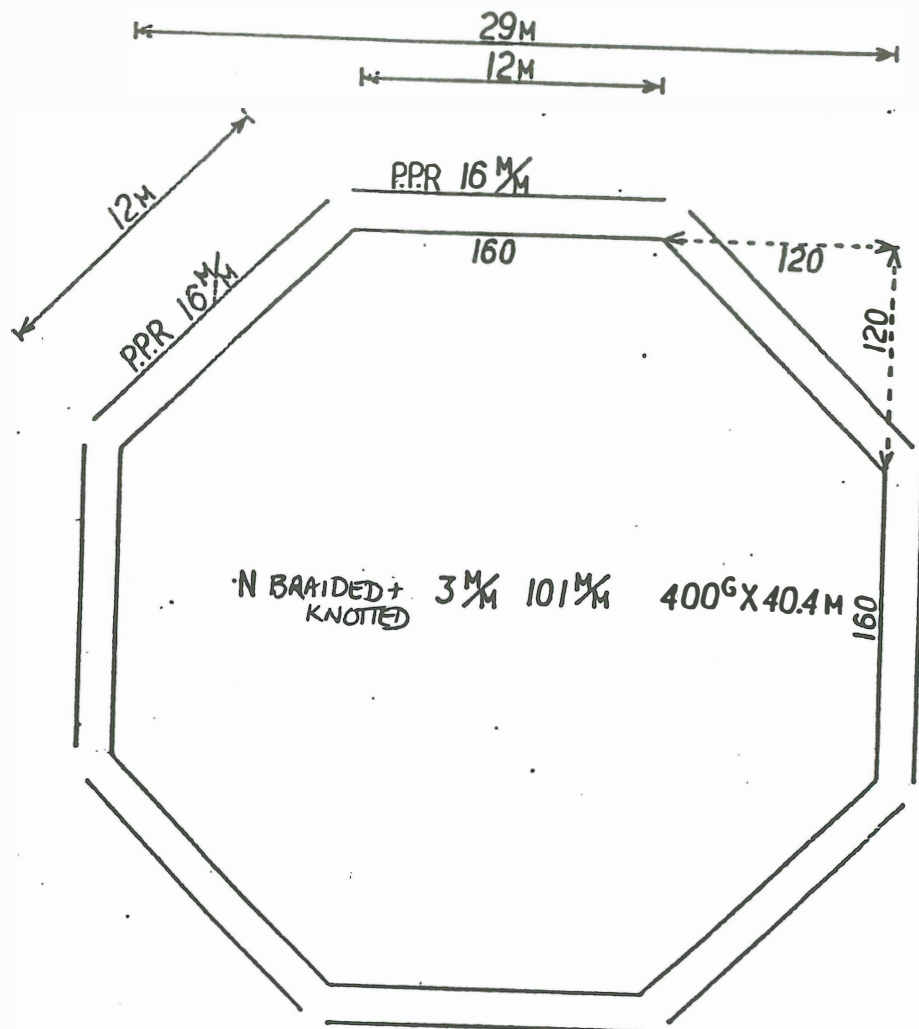

- 29 After construction on site, the first research pontoons in 1991 were towed into position. A belly rope was tied in a cross shape across each pontoon frame to minimise warping during towing, and to prevent the frame from breaking up. Each pontoon took one hour to be towed the seven km to the farm site from the shore construction area. The detail of the operation is in *Figure Thirteen*.

## Fish Capture and Transport

30. **Fish Capture and Transport:** The experimental farm started by capturing fish by poling and transporting them to the farm in the boat tanks. The type of boats used were:

- (1) 1991 - "Empris Lady", 171 tonnes owned by Bluefin Exporters Pty. Ltd.
- LOA 24.5m (DWL 21.5m)
  - Breadth 7.3m
  - Depth 3.51m
  - Rake of keel 18.5m
  - Displacement to 3,200 WL 241 91 tonnes
  - Lightship - 123.09 tonnes
  - Deadweight to 3,200 WL - 118.88 tonnes.
  - Gross tonnage - 171.22 tonnes
  - Four live-fish tanks with each 5 cubic metre  
Tanks 1 and 2 (total 17.8 cubic metres) and 3 and 4 (5 cubic metres)
  - Seawater circulating pump system with total change-over of 15 minutes.
- (2) 1992 - "Fina K" owned by Fina K Fisheries Pty Ltd
- LOA 27.25m
  - Breadth 7.3m
  - Depth 3.7m
  - Engine 1050 HP
  - Six live fish tanks (98 cubic metres in total).

31. Both vessels operated effectively though there were early problems with "Fina K". The coils in the "Fina K" tanks initially damaged the fish until the coils were covered with marine plywood (again covered in turn with dark green vinyl-coated canvas). In addition, when the initial pump capacity of 1080/min for all six tanks proved inadequate, a 1800/min pump was fitted,



and then a 2300/m. This created on-going problems with the suction intake. On the second voyage the suction intake was improved. On the third voyage various other remedial methods were tried including pointing the suction intake to the rear. The gain was only marginal and in the end almost all pumps were replaced.

33. **Equipment for Handling Live Fish** (see *Figures Eighteen, Nineteen and Twenty* for sketch examples): This included:

(1) Vinyl-coated canvas water tank.

- Model 1 - 1200 x 350 x 700mm diameter steel tubing, sky blue 1.00m vinyl sheet.
- Model 2 (improved version): 2000 x 1200 x 450mm. The frame was made of one-inch steel tubing with blue, vinyl-coated canvas sheet of thickness 1.0mm, with the upper steel tube surfaces covered with the same protective sponge used on boat cooling tanks to prevent injury to the fish. Also, 100mm thick urethane matting was laid on the floor of the tanks to minimise injury.
- Model 3 (improved version) was the same basic specifications but the frame height was raised 180mm. When captured, fish were guided into the tank where the hook was removed, hook injury locations identified and a decision made whether to keep the fish for grow-out. If selected the individual fish was calmed in this temporary tank before transfer to the main tanks.

(2) Stretcher

- 1991 - 1,000mm long, 500mm wide, 200mm deep with 200mm handles on each side. The material was 1.00mm thick vinyl-coated canvas sheeting - the handle was 40mm thick bamboo. Holes - 20-25mm diameter - were punched at 30mm intervals to assist drainage.
- 1992 - changed to 1,000mm length, 300mm width, 150mm (H) to ease handling. The fish were not only calmed in the stretcher but it was used to transfer fish to the main tanks. Two people were required at all times.

(3) To get fish out of the boat tanks into the farm pontoons we tried a range of buckets. The final model used was an upper frame of 25mm steel tubing and three ropes made of 12mm polypropylene. Netting was fitted to the upper 90mm. When transferring fish the bucket was lowered into the hold then a spoon net (see below) was used to guide the fish into the bucket which was then winched up. The research project went through a series of developments to find the correct structure. For example, in the second model the four rope support was reduced to three to avoid the fish becoming tangled. Even the final model was never an optimum way of extracting the fish from the tanks.

- (4) Spoon net - this was improved over the years to 600mm diameter, 150mm depth, and nylon raschelle net 210 d/25, 13mm mesh with a 2-inch thick bamboo handle 2,500mm long. The spoon net was used to guide fish in the hold into the submerged bucket by placing it in front of the fish. By 1993 this had been further improved to a basket concept which scooped up the fish from the hold onto vinyl canvas and then into the pontoon.
- (5) In 1992, the research project developed a scoop basket to replace the scoop net. Using the basket the fish were scooped up and directly transferred in the vinyl coated canvas.

### Capture Methods/Area

33. The capture method used during 1991 and 1992 was poling. This was largely replaced in 1993 and 1994 by purse seining the fish (see below). Therefore the details of the poling system is for largely history only, though it is still used for about 2 per cent of total capture.
34. The research farm used normal Australian poling systems - with fibreglass rods 2.0-2.5m long nylon monofilament lines 1.5-2.0m long. The Australian traditional hook was used first but resulted in excessive injury around the eyeball. A replacement Japanese hook (No. 22 sea bream hooks from Saganoseki in Kyushu) was more successful.
35. The grounds fished were mainly around Rocky Island - 35° 50' south/134° 43' east - and Cabbage Patch - 35° 17' south/135/31' east. These are traditional inshore fishing grounds, 5-10 hours steaming to Port Lincoln and with smaller (more manageable) fish. The season at Rocky Island extends from February to June and between April to June at Cabbage Patch.
36. The number of fish caught on each trip varied with fish size, sea condition and fish availability. On average only 60-70 fish (average weight 13-16kgs) were transported in "Empris Lady" and "Fina K." However, as technology improved and bigger vessels were used (eg. "Sea Princess") over 100 fish were regularly brought in per trip. Each trip lasted roughly 36 hours - at a cost to OFCF and ATBOA of around \$5,000/trip.
37. As above, the fish were poled into the vinyl-coated canvas sheet tank. The tank already contained two or more stretchers. The crew then took the nylon gut and guided the fish into the stretcher. In the stretcher the hook injury was checked, the hook removed, and fish assessed for:
  - (1) Heavy bleeding
  - (2) Hook penetrating the upper jaw, and the optic nerve status
  - (3) Hook swallowed, or hook stuck in the lower jaw.

After pacifying the fish, generally by placing the hands over the eyes, two crew lifted the stretcher and the fish was slid into the hold.

38. When transferring each fish into the hold, the fish already in the hold were observed to see whether any were bleeding, or floating to the top, or swimming differently from the others.

Fig. 18 Sketches of equipment used for handling fish

Small tank

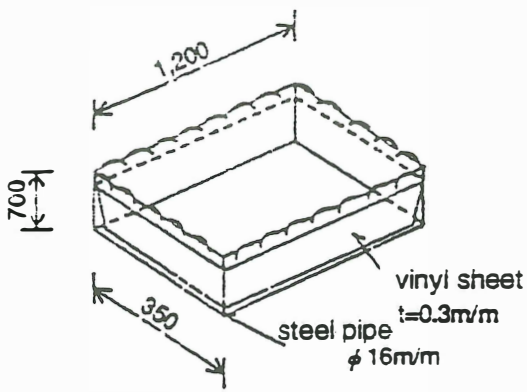

Small tank (improved version)

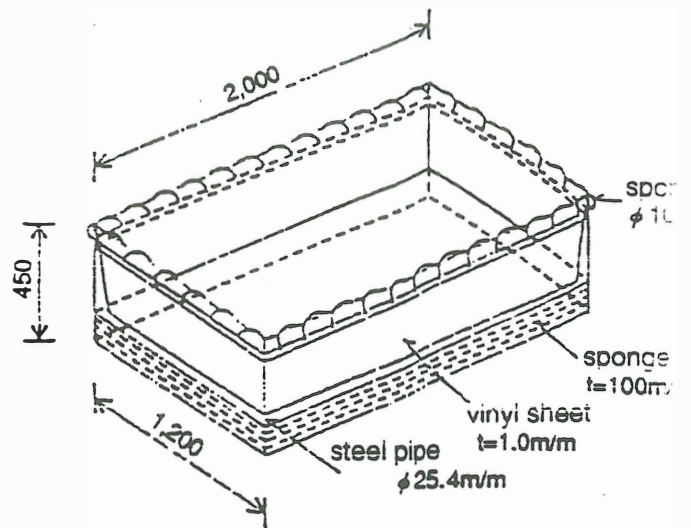

Stretcher

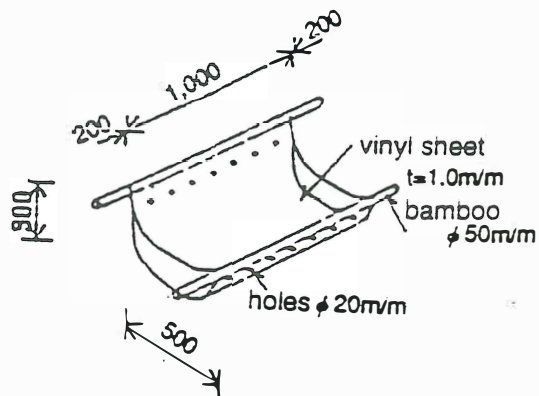

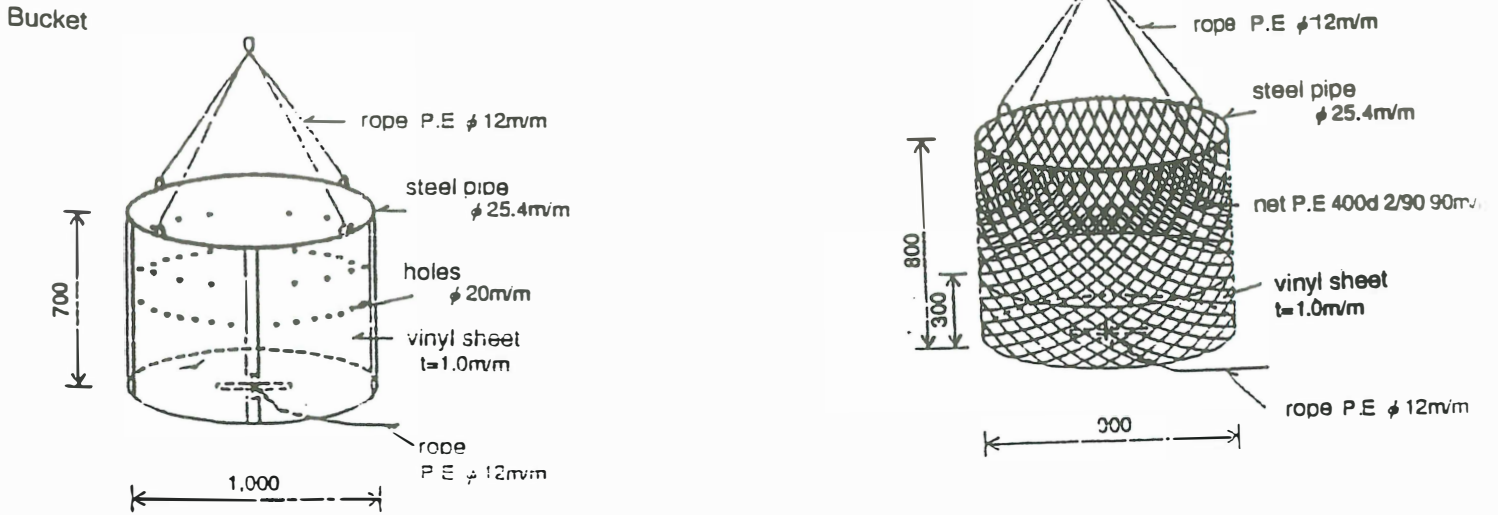

Aerator

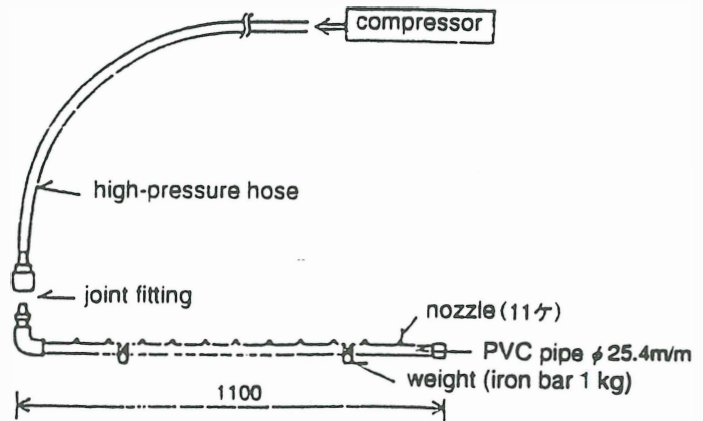

Fig. 19 Sketches of equipment used for handling fish

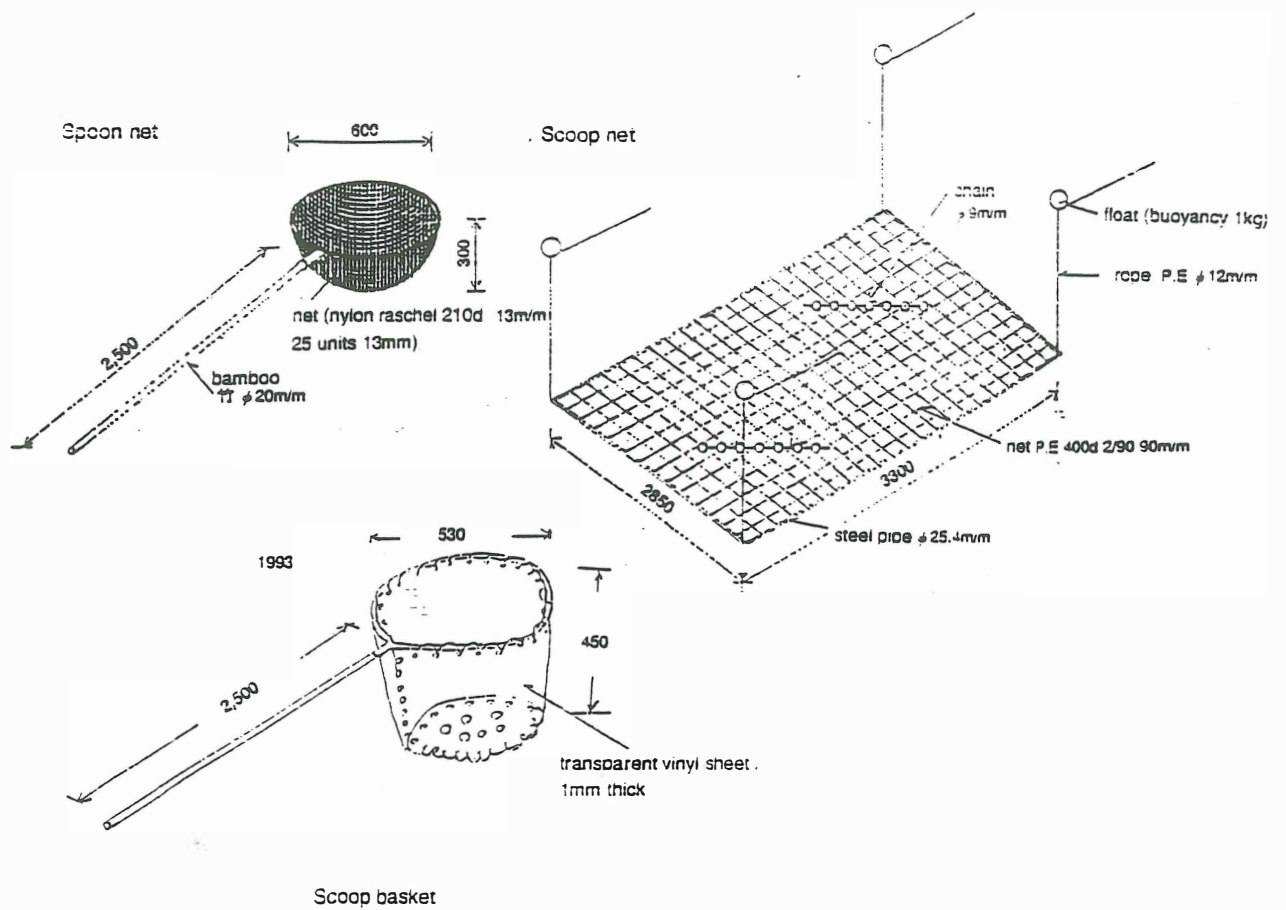

Fig. 20 Sketches of equipment used for handling fish

## Transport and Transfer of Fish

39. The sea-water in the live fish holds was replaced during the trip by using sea-water circulating pumps (see above). Changes in the dissolved oxygen content of the water in the holds were comparatively slight - a good example is from 9.7 mg/l before capture to 7 mg/l during the trip to Port Lincoln (see *Table One* ).
40. During darkness, underwater lights were turned on in the holds so that the fish would not panic and hit the walls.
41. On arrival at the farm the vessel was always moored on the leeward side of the pontoon, for efficiency reasons. For transfer of the fish, the water level in the holds was reduced and, in 1991, the bucket lowered into the hold. The fish was guided into the bucket by the spoon net (see above). The time taken depended on sea conditions but was generally about 1.5 hours for 70 fish.
42. Note that the progress to a scoop basket in 1992, and to using the small tank as a transition to the pontoon, meant the fish were more relaxed. During the small tank period, the fish were bathed for two minutes in dissolved 125g/100ltr of liquid tetracycline hydrochloride. While this seemed to provide some medicinal benefit to the fish, this was probably outweighed by the increased handling and time out of the water.
43. The results of the catching and transporting in 1991 and 1992 are detailed in Tables Two, Three and Four as gathered by OFCF staff. The survival rates were much higher than expected, though relatively poor compared with the new method (from late 1992) of towing a pontoons of fish largely caught by purse seine (see below).
44. Transfer to the farm pontoons is often more difficult as the fish are more relaxed. Again, the towing and farm pontoons are joined together. To entice the fish, sometimes bait fish are scattered close to the exit of the towing pontoon exit panel. Other methods used in the past including lifting the nets either manually or by using air bags.
45. Poling has largely been replaced by purse seining, and towing to Port Lincoln in large pontoons. It is this change which has enabled the industry to move to large volume. The towing pontoons and transfer techniques developed throughout 1993 and 1994 to the point where trips can bring over 100 tonnes each.
46. The purse seiner operates by shooting the net around the school of tuna, drawing it as far as possible without damaging the fish and bringing alongside the towing pontoon. The seine and towing nets are then laced together by divers and the fish are enticed into the tow net by chumming and/or the diver. The pontoon is then towed back slowly (1-2 knots for up to 14 days) to the farm where the fish are then again transferred to another pontoon, or the tow pontoon is anchored and used for grow-out. The actual towing specifications used from early 1993 are in *Attachment Five*.
47. These new methods also have the big advantages of catching bigger fish, and equally important the fish are generally never handled, meaning less stress and less injury.

**TABLE 1****Changes in Dissolved Oxygen and Water Temperature in Holds of Carrying Boat During Transit (1)**

Time	Tank 1			Tank 2			Tank 3			Tank 4		
	No. Fish	D.O. (ml/l)	Water Temp. (°C)	No. Fish	D.O. ml/l	Water Temp. (°C)	No. Fish	D.O. (ml/l)	Water Temp. (°C)	No. Fish	D.O. (ml/l)	Water Temp. (°C)
10:20	0			0	9.7	19.4	0			0		
10:40	0	9.8	19.4	0			0			0		
11:13	3			3	9.5	19.6	2			2		
11:26	6			5	9.2	19.5	5			5		
11:43	9			9			9			8	7.8	19.4
11:57	13			12	8.1	19.5	10			10		
12:00	14			14			11			11	7.1	19.5
12:20	17	7.4	19.6	17	7.6	19.6	11	6.9	19.6	8	7.2	19.6
13:00	17	7.4	19.4	17	7.3	19.4	11	7.1	19.4	6	7.5	19.4
15:00	13	8.2	19.9	17	8.0	19.9	10	7.8	19.9	6	8.9	19.9
17:00	13	8.7	18.3	17	8.4	18.2	9	8.2	18.3	6	8.9	18.5
19:00	13	8.1	20.3	17	7.8	20.2	6	8.3	20.3	6	8.4	20.3
21:00	13	8.0	21.3	17	7.6	21.3	6	8.1	21.4	6	8.2	21.4
22:00	13	7.8	22.5	17	7.6	22.5	6	8.0	22.7	6	8.2	22.6

Source: OFCF Experts

- (1) Based on transport of fish from Rocky Island, around 10 hours from Port Lincoln, on 25 February 1991.

**TABLE 2****Results of Catching, Transport and Tank Stocking -  
Data for 1991 (1)**

Hold No.		1		2		3		4		Total		Survival	Caught
Hold capacity m <sup>3</sup>		17.8		17.8		9.6		9.6		54.8		Rate (%)	Place (2)
Trip	Date	In	Mort	In	Mort	In	Mort	In	Mort	In	Mort		
1	25/2	17	5	17	2	12	8	11	7	57	22	61.4	R I
2	19/3	10	5	14	8	-	-	-	-	24	10	58.3	R I
3	16/4	23	0	23	1	11	0	14	6	71	25	690.1	C P
4	17/4	24	15	24	2	12	3	11	5	71	25	64.8	C P
5	18/4	21	1	24	1	12	1	12	0	69	3	95.7	C P
6	19/4	25	0	25	0	14	1	14	1	78	2	97.4	C P
7	20/4	27	2	27	11	14	1	13	1	81	15	81.5	C P
8	29/4	24	10	24	0	14	5	-	-	62	14	77.4	C P
9	3/5	24	4	24	1	14	2	14	0	76	7	90.8	C P
10	4/5	27	0	27	1	14	3	14	6	81	10	87.7	C P
11	10/5	14	0	12	1	7	0	6	0	39	0	100	C P
12	11/5	26	1	27	0	15	3	13	4	81	8	90.1	C P
13	13/5	27	0	27	0	14	1	13	3	81	4	95.1	C P
14	14/5	21	0	21	0	10	0	11	2	63	2	96.8	C P
15	20/5	30	0	30	3	14	0	13	0	87	3	96.6	R I
16	21/5	28	1	28	2	13	1	10	2	79	6	92.4	R I
17	22/5	28	0	29	1	13	0	12	0	82	1	98.8	R I
18	23/5	25	1	27	0	14	1	13	0	79	2	97.5	
Total		421	45	430	34	217	30	194	37	1261	141	88.8	
Average per trip		23.4	2.50	24.2	1.88	12.8	1.76	12.1	2.31	70.0	7.83		
Survival rate (%)		89.3		92.1		86.2		80.9		88.8			
Stocking (fish/m <sup>3</sup> )		1.3		1.2		1.3		1.3		1.3			
Kg per m <sup>3</sup>		18.0		17		18.3		17.8		17.6			

Source: OFCF Experts

- (1) Trips by "Empris Lady". Fish average FL 86.7cm and 13.77kg - 79 samples  
 (2) R I = Rocky Island : C P = Cabbage Patch



**TABLE 3 - Results of Catching, Transport and Tank Stocking -  
Data for 1992**

Hold No.		1		2		3		4		5		6		7		Survival
Hold capacity		10m <sup>3</sup>		10m <sup>3</sup>		18m <sup>3</sup>		18m <sup>3</sup>		20m <sup>3</sup>		20m <sup>3</sup>		96m <sup>3</sup>		rate
Trip	Date	In	Mort	In	Mort	In	Mort	In	Mort	In	Mort	In	Mort	In	Mort	%
1	1/4	9	9	10	10	13	13	18	18	15	15	15	15	80	80	0
2	5/4	7	6	7	7	15	12	12	9	15	10	15	13	71	57	19.7
3	12/4	4	1	3	1	6	0	8	0	9	1	9	0	39	3	92.3
4	13/4	5	0	3	0	10	6	10	2	10	2	10	3	48	13	72.9
5	14/4	5	1	4	1	10	1	12	0	9	0	10	1	50	4	92.0
6	16/4	5	0	5	0	11	3	11	1	11	1	11	1	54	6	88.9
7	17/4	7	0	6	4	11	3	11	2	14	0	13	2	62	11	82.3
8	18/4	3	0	2	0	5	0	7	0	5	0	6	0	28	0	100
9	23/4	5	0	5	0	11	1	11	0	12	0	12	0	56	1	98.2
10	24/4	7	2	6	2	12	4	12	2	12	0	12	1	61	11	82.0
11	25/4	5	1	5	1	9	2	10	2	13	1	12	1	54	8	85.2
12	26/4	3	0	3	0	9	2	8	0	8	0	8	0	39	2	94.9
13	28/4	6	0	5	0	11	2	11	1	13	1	11	2	57	6	89.5
14	29/4	7	2	8	2	13	6	12	3	23	1	13	5	66	18	72.7
15	5.9	8	3	7	0	15	2	14	4	14	0	12	1	70	10	85.7
16	10/5	6	0	6	0	11	1	12	1	12	0	12	0	59	2	96.6
17	14/5	11	0	9	0	20	5	20	0	21	3	22	7	103	15	85.4
18	18/5	8	4	8	2	12	4	13	5	12	5	17	6	70	26	62.9
19	19/5	6	1	6	1	12	4	13	3	14	2	15	4	66	15	77.3
20	20/5	6	0	6	0	13	4	12	3	10	0	13	0	60	7	88.3
21	21/5	8	1	7	0	12	2	12	0	14	1	14	0	67	4	94.0
22	22/5	7	0	7	0	13	1	12	0	14	0	14	1	67	2	97.0
23	23/5	7	0	8	0	13	0	13	2	14	1	14	1	69	4	94.2
24	23/5	7	1	9	1	14	0	16	0	16	1	17	1	79	4	94.9
25	2/6	9	0	9	0	15	0	15	0	18	0	20	0	86	0	100
26	6/6	10	1	10	1	17	1	16	0	20	1	20	1	93	5	94.6
27	7/6	12	0	13	0	17	0	18	0	21	0	25	1	106	1	99.1
28	8/6	12	0	12	0	18	0	18	0	24	0	26	0	110	0	100
Total		195	33	189	33	348	21	357	57	383	46	398	67	1870	315	83.2
Survival Rate %		83.1	16.9	82.5	17.5	94.0	6.0	84.0	16.0	88.0	12.0	83.2	16.8		16.8	
Fish/m <sup>3</sup>		0.7	0.12	0.68	0.12	0.69	0.04	0.71	0.11	0.68	0.08	0.71	0.12	0.7	0.12	
kg/m <sup>3</sup>		7.6	1.3	7.3	1.3	7.5	0.5	7.7	1.2	7.4	0.9	7.7	1.3	7.6	1.3	
Average														66.8	11.3	

**TABLE 4****Summary of 1991 and 1992 Catching, Transport and Tank Stocking**

Catching Year	Holds on Boat (No.)	Total Capacity of Holds (m <sup>3</sup> )	Av. No. Fish Carried/Trip	Av. Wt. Fish Carried/Trip (kg)	Av. No. Morts./Trip	Stocking in Tanks (fish/m <sup>3</sup> )	Stocking in Tanks (kg/m <sup>3</sup> )	Survival Rate (%)
1991	4	54.8	70.0	965	7.8	1.3	17.6	88.8
1992	6	96.0	66.8	912	11.3	0.7	9.5	83.2

Source: OFCF Experts

48. The towing specifications (see *Attachment Five* ) were developed by the tuna farmers and by Graham Johnson (Tasmania), through work on the AMC flume tank. These specifications were then refined in co-operation with the then SA Department of Marine and Harbours. The towing speed is generally 1-2 knots, with trips of up to 10 days. The fish are fed on the way, though there is normally a short period in which they will not feed.

### Results of Capture and Transport

49. Table Four summarises the results of the transport of the fish from catching to the farm. Survival rates were high but did worsen between 1991 and 1992. The reason for this was the inadequate pumps used to recirculate the sea-water.
50. In 1991, of the 1261 fish placed in the holds 141 died, an 88 per cent survival rate - a good result compared with NBT but still inadequate. The average fish density in the holds was 18.1 kg/cubic metre - or 1.2-1.3 fish per cubic metre - spread equally across the holds.. The trip from Rocky Island area was 10 hours compared with 5 hours from Cabbage Patch but there was little difference in survival rates.
51. As above, the survival rate worsened to 83 per cent in 1992 due to the inadequate pumping system. Note again also that to try to better manage fish injury some tetracycline powder was used in 1992 on transfer from vessel to the farm pontoon, but as above, there was probably no net benefit because of the increased handling required.
52. Surprisingly, the larger fish (15kg) and smaller fish (8kg) had a close survival rate. This was the opposite of the NBT experience where larger fish had very high mortality.

## The Grow-Out Results

### Results of Initial Grow-Out

53. There were high mortalities in both 1991 and 1992 between 10-30 days after transfer to the farm pontoons. Mortalities before 45 days were attributed to transfer mortality, and to natural mortality after that.
54. The results are outlined in *Table Five*. The initial mortalities seemed due to a diverse range of factors - some pure accident. For example, during a transfer in June 1992 the boat moved away from the pontoon with the very strong lights still on. The fish panicked, hit the net and 181 died in the following 8 days.

**TABLE 5****Grow-out Data**

No.	PONTOON No.	1	2	3	4
1	Grow-out dates	13/5-17/12 (92)	19/3-23/5 (93)	5/4-23/5 (93)	19/5-22/3 (93)
2	Days of grow-out	219	797	413	338
3	No. of fish into pontoon	488	632	750	805
4	Average weight into pontoon (kg)	13.77	13.77	15.4	11.5
5	Total weight into pontoon (kg)	6,720	8,703	11,550	9,258
6	Initial loss (45 days from stocking)	123	137	315	415
7	Total weight of (6) above (kg)	1,694	1,886	4,851	4,773
8	Normal mortality (after 45 days)	12	12	5	19
9	No. of fish harvested	353	269	94	371
10	Total weight harvested (kg)	5,888	5,763	2,115	7,153
11	Estimated remaining fish	-	214	336	-
12	Estimated average weight (kg)	-	45.0	32.0	-
13	Estimated total harvested weight (kg)	-	9,630	10,752	-
14	Weight increase (kg)	862	8,576	6,168	2,668
15	Total feed given (kg)	53,299	265,937	137,693	54,302
16	Survival rate (%)	72.3	76.4	57.3	46.0
17	Food conversion rate	61.8	31.0	22.4	20.3
18	Grow-out area per fish (except initial losses) m <sup>3</sup> /fish	13.6	9.9	11.4	11.4
19	Area of pontoon (m	4,946	4,946	4,946	4,375

Source: OFCF Experts

## Results of Longer Grow-Out

55. For the first 30-45 days in the pontoons, feed consumption was very low, and there was an initial weight loss of up to 25 per cent. Thereafter the weights rose sharply. For example, despite the initial weight loss, the 13.7 kg fish placed in the pontoons in May 1991 had grown to 30-32kg one year later. They further increased to 40-45kg in the following year, and four years after transfer were up to 90kg.
56. The weight gains are roughly the same as for NBT - where a grow-out of 17kg fish reached 29kg in one year and 40kg in 2 years (pers. comm. Koga).
57. The average weight gain was 0.3-1.0kg./month in winter (July/September) and 2.5-3.5kg in summer (December to February). Subsequent experience after the Project is that high summer growth can be over 5kg/month. This suggests there is a big advantage in early summer capture - now from late-November, although the impact of sustained higher water temperature (eg over 25°C) on juvenile SBT may be negative.
58. The Feed Conversion Ratio (FCR) differed sharply between pontoons. For example:

	<u>Feed Conversion Ratio of Kgs of Pilchards to Achieve a Kg of Tuna Growth</u>
<u>1991</u>	
Pontoon One	61.8
Pontoon Two	31.0
<u>1992</u>	
Pontoon One	22.4
Pontoon Four	20.3

The 1991 results largely reflect both overfeeding, and the fish being transferred close to winter with very little summer growth.

59. When pontoon one is excluded, the SBT growth rates were roughly the same as NBT ie. between 8.8-28.6 FCR (pers comm. Koga).
60. Variations in demand feeding in 1991 are outlined in Tables Five to Seven. Unexpectedly the feeding rate (kg/body weight) was high in early winter (June) at around 10 per cent. We now recognise that this was unusual and reflected the compensatory feeding after the sharp loss in weight after capture. With improved capture techniques and little stress, subsequent years have shown the rate peaking in mid-summer and sliding gradually to a low in mid-winter.
61. Tables Eight to Nine detail feed rates in various pontoons and relationships with air and water temperatures. This is shown graphically in Figures Twenty One to Twenty Six.

## **Stock Density**

62. The stocking density varied very little between 1991 and 1992 - averaging 11.4 cubic metres of water per fish. In 1991 - pontoon one was 13.6 cubic metres/fish, and pontoon two only 9.9. Despite the difference there was very little variation in the fish quality between the pontoons.

## **Grow-out Management**

63. This was relatively simple:
- (1) Diving in the pontoons took place every day in the first one and a half months to remove dead fish.
  - (2) Feeding was twice per day (generally 9:00 am and 4:00 pm) for six days a week. The SBT have tended since 1992 to eat daily up to 12 per cent of their body weight in the peak of summer, reducing to around 4 per cent in winter (see *Feeding* below).
64. Currently, divers tend to do inspection dives at least once every two days, depending on other work requirements. On the original research farm, after the initial period of intensive diving, the pontoon was inspected every day for dead fish, and once every 7-8 days to assess net fouling, and net tears.
65. In contrast to the regular net cleaning required in Tasmanian salmon, net fouling in the Boston Bay area is only moderate, despite the slower current speeds. This means the nets are cleaned only once a year - generally by splitting them into panels and cleaning onshore or offshore away from the farms. No anti-fouling is used. Farms are constantly experimenting with different mesh and braid specifications. Where some cleaning is required during the year, this can be done by a net cleaner but as yet no automatic cleaner has been satisfactory. Some farms use more simple methods such as tyres roped to the pontoon to take advantage of the current. The research farm purchased a Idema net cleaner with one high pressure connecting hose and aluminium 3 metre telescopic extension handle (\$4,640), plus a K'Archer HD 1050 pressure pump with inlet filter to power the unit (\$3,690). The unit proved only partly satisfactory because it was labour intensive and required constant maintenance.
66. Subsequent research (*Cronin, 1995* ) found that oxygen exchange of the net fouling contributed less than 2 per cent to oxygen depletion in a pontoon. However, the fouling in most nets would be expected to have a significant effect on mass water exchange through the pontoon with an associated oxygen loss from normal flow.











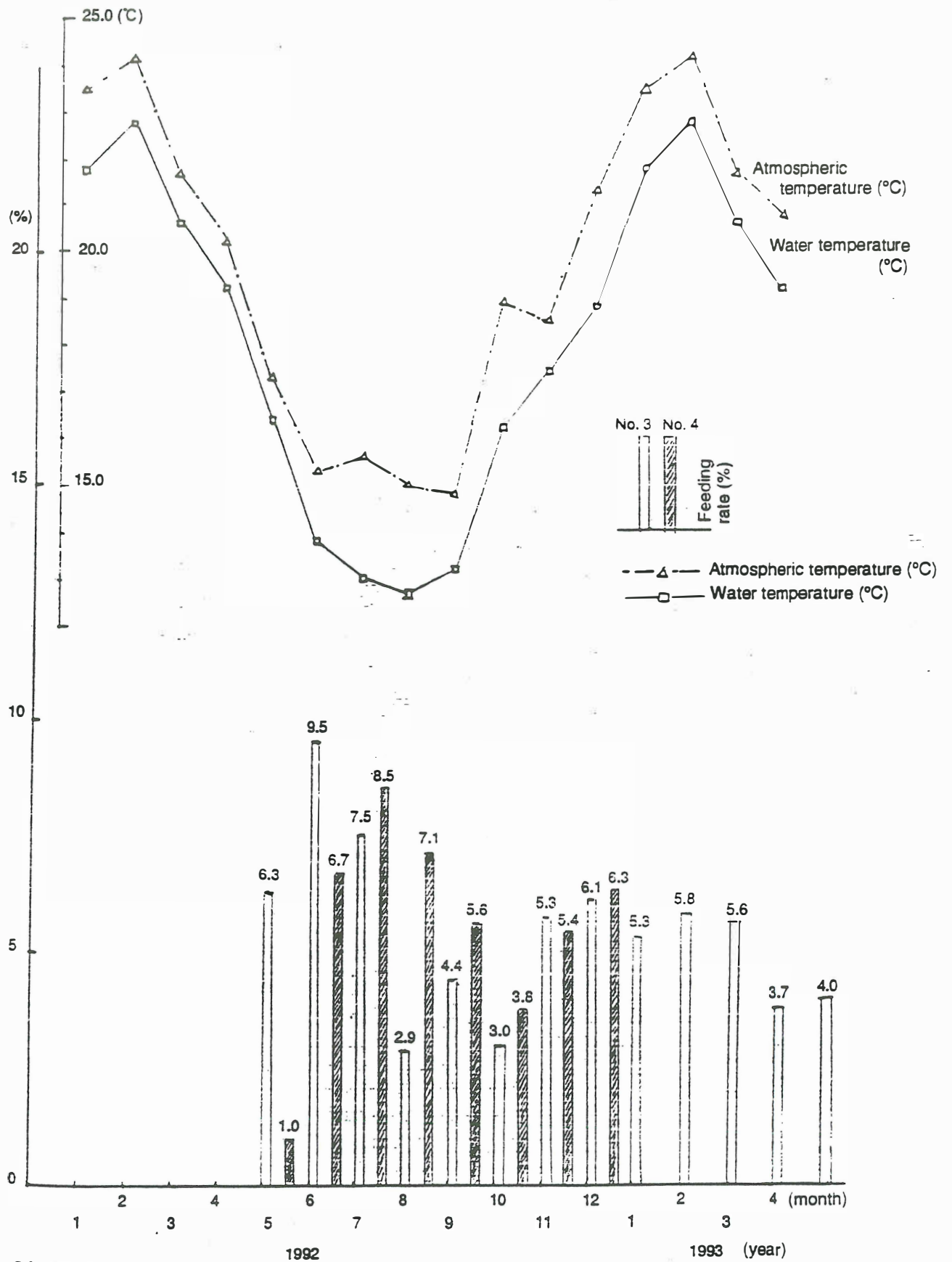
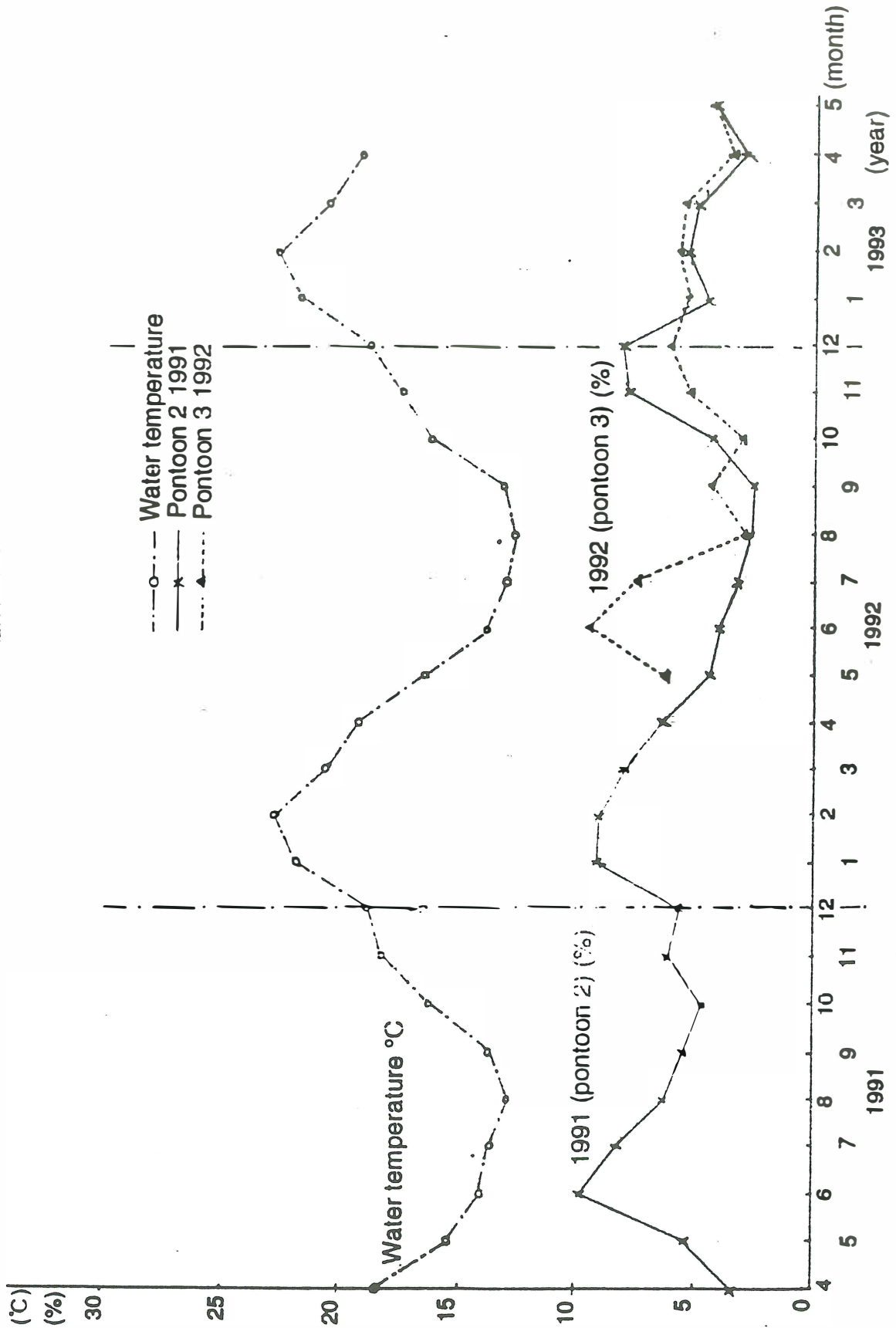
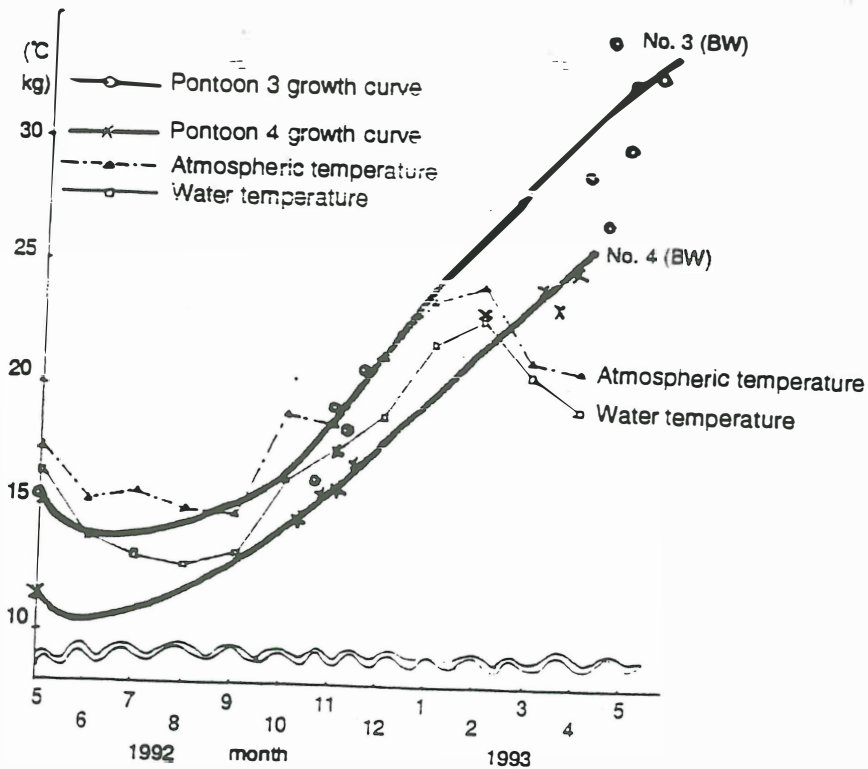
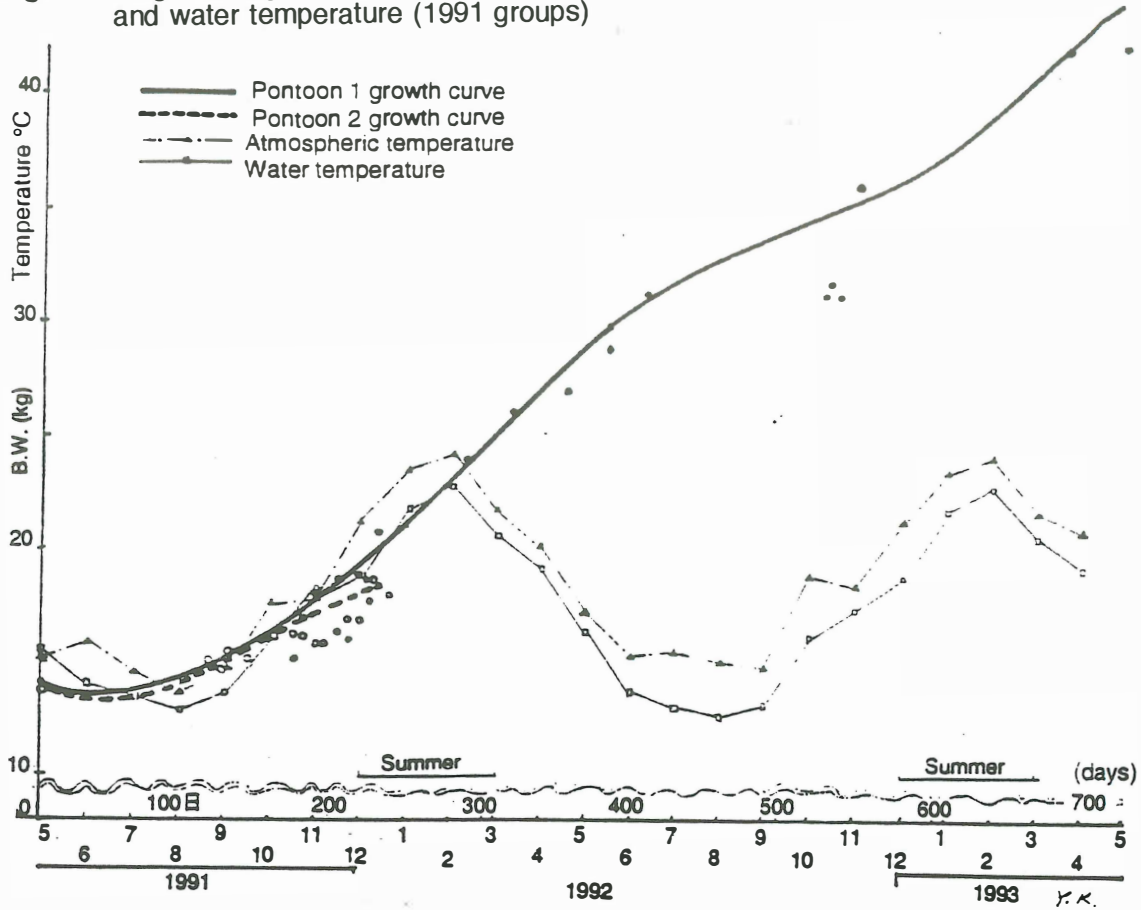

Fig. 21 changes in atmospheric & water temperature and average daily feeding rates pontoons 3 and 4 (1992-93)

Fig. 22 Changes in water temperature and average daily feeding rates in pontoons 2 & 3, featuring long-term rearing



**Fig. 23** Progress of growth of farmed southern bluefin tuna and changes in atmospheric and water temperature (1991 groups)



**Fig. 24** Progress of growth of farmed southern bluefin tuna and changes in atmospheric and water temperature (1992 groups)

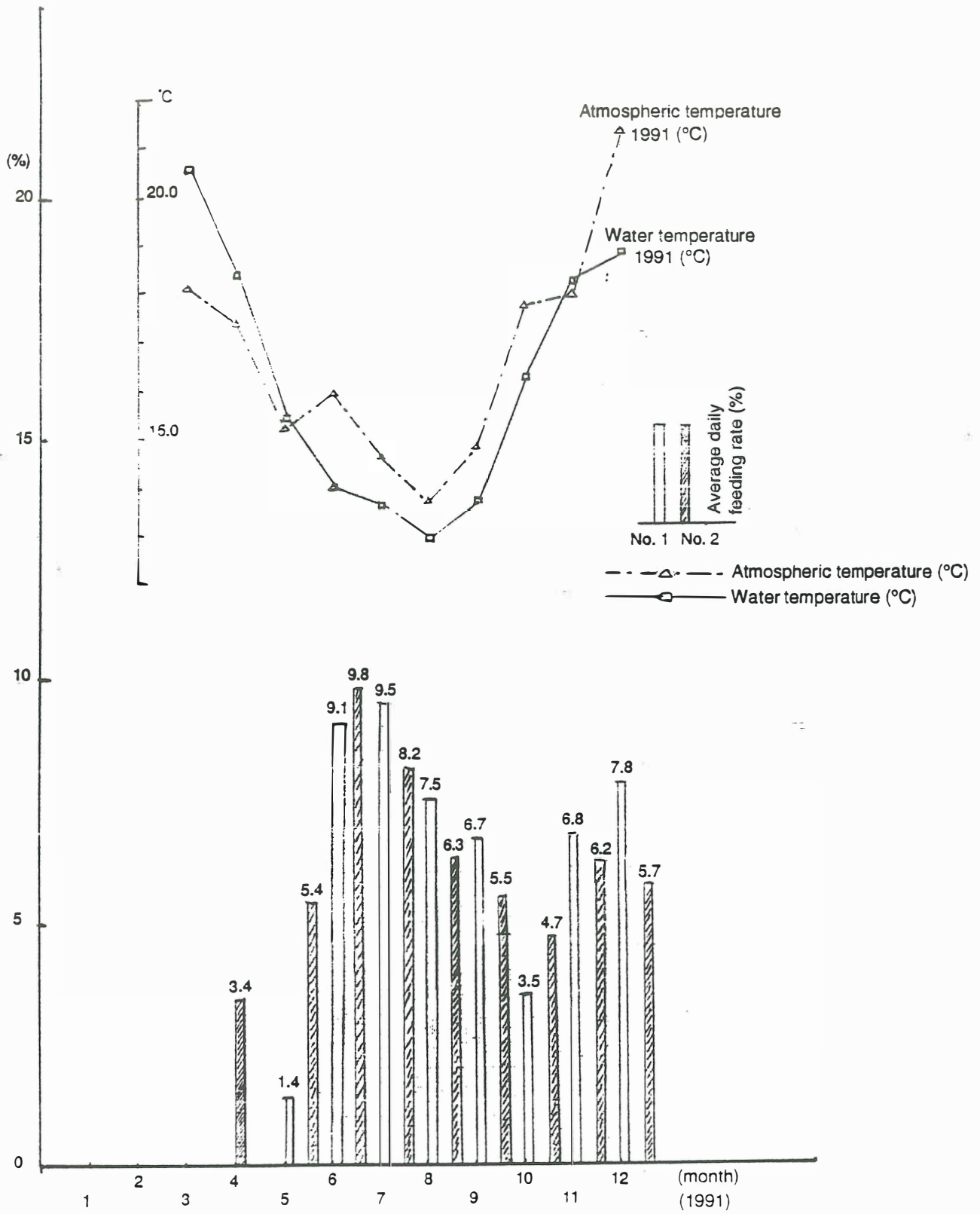

**Fig. 25** Changes in atmospheric & water temperature and average daily feeding rates (1991 groups) pontoons 1 and 2

## Feeding

67. In general, the feed has not changed over the 1991-95 period-being largely pilchards from Port Lincoln and WA (*Sardinops neopilchardus*) - and more recently imported pilchards and herrings from Europe and pilchards from California. Other points are:
- (1) The pilchards are generally 10-22cm in length.
  - (2) FIRDC's initial scepticism of this proposal centred on obtaining adequate feed within Australia. This was justified. Points are:
    - (a) The small amounts of pilchards required for the initial project were caught under a special licence issued by the SA Government. Previously only tuna boats catching live bait for fishing operations had been allowed to take pilchards commercially. Even with the development of a 3,500 tonne Port Lincoln pilchard fishery, this is inadequate to supply the farms. Even a further 5,000 tonnes from Western Australia has not been adequate.
    - (b) During 1993, one major farmer tried Tasmanian jack mackerel but it has the problems of:
      - Availability is uncertain.
      - It is generally too big and needs to be cut up.
      - When landed in Victoria and trucked to Port Lincoln it is more expensive than other options.
  - (3) Imported feed is readily available at competitive prices from Africa but require very large shipments beyond the freezer capacity in Port Lincoln. In contrast pilchards from Japan (until 1995), Europe and California, with regular container loads, have the advantages of not having to hold large stocks, and so are of better quality. *Note*: Importing feed from Japan also has the advantage of providing a natural currency hedge against fluctuations in the \$/Yen exchange rate (ie. for tuna prices). The reduced cold store capacity in Port Lincoln - down to 3,000 tonnes in 1993 - was a problem. However, another 1200 tonnes was built in 1995 and 1996.
68. The ATBOA has a strong link with the CRC program on nutrition (see later), targeting at finding a suitable pellet for the tuna. From 1994 to 1997 the research farm has been testing a range of pellets. The latest results show competitive costs, but growth rates are far below that of pilchards. Another initial major problem was weaning the fish onto pellets - at first they took up to two weeks and lost condition in that period, as well as weakening their resistance to any health problems. This problem has been largely overcome by the use of attractants in the pellet.
69. The feeding techniques developed by the research farm in 1991 and 1992 were as follows. The frozen pilchards were taken from cold storage for thawing one or two days before use. Obviously assessing how much the fish

would eat on the day was largely guess work. The thawed bait was then transferred to the farm in the work boat. At the farm the pilchards were mixed with the vitamin (see below) powder which contained a sticky substance for adhesion of the powder. The feed was then scattered across the surface of the pontoon by a shovel.

70. Although wet feed remains the dominant feed, the method of feeding has sometimes changed from the shovel technique to thawing of blocks (about 15kgs) in a small cage in the centre of the pontoon. This saves the need to thaw the feed up to 24 hours before feeding, but has proved to have some problems. These include:

- (1) Uneven growth between fish in the pontoon, as there does appear to be a feeding hierarchy.
- (2) More environmental problems under the pontoons.

Feeding techniques are moving back to shovelling, or to blowers to get a more even spread of feed across the pontoon.

71. The research farm, from the start, used a supplementary vitamin powder mixed with the wet feed at a 1:100 ration. Initially the powder was imported from Japan (¥550/kg fob) but has now been replaced by local powders. The imported powder ingredients were tochlorophenol, thiamine nitrate, riboflavin, pyridoxine hydrochloride, nicotine-acid amide, calcium pantothenite, folic acid, iron peptide, xanthan gum, starch, seaweed powder, silic acid (*anhydride*) and beer yeast powder.
72. There is some doubt how much these supplements accelerate injury recovery because of the loss of powder in the water. However, recent evidence is that they are reasonably effective in stress and injury recovery, and in maintaining better flesh colour. Obviously the system of thawing in the pontoon itself excludes the use of supplements.
73. The feed conversion rates in 1991 and 1992 were extremely high because of the method of transport which led to a significant period of not eating due to stress. The feed conversion ratio (FCR) was gradually improved from the early research farm days to be around 15:1 in mid-1993. Since then, it has been substantially improved by the capture of the fish earlier in the summer (eg. December/February). This has enabled growth of up to 5kg/month, with high daily feed/body weight levels, but nevertheless a much better FCR.
74. Note that:
- (1) Feed must be block frozen - freezing in brine had serious effects on the tuna because of salinity. Brine-freeze feed caused fish on the research farm to swim with the dorsal and tail fins breaking the surface, and show little appetite.
  - (2) A 1994 study by IFIQ of changes in the protein and other qualities of frozen tuna feeds showed significant thawing losses and the impact of poor storage practices. This has led to a reassessment of the techniques used (see *Attachment Eight* for a summary of the recommendations in that Report).



## Harvesting

### Harvesting

75. The first research farm harvest took place on 20 August 1991. The harvesting techniques differed little from the pole and line traditionally used. It was only in 1994 that some of the industry moved towards harvesting by net. The merits of the line and net methods (crowding the fish) are still being assessed. The issues remain:
- (1) When harvesting large numbers (eg. over 80 fish), netting is the only effective method.
  - (2) In winter it is very difficult to attract the fish to bite, and netting is the only effective harvesting method.
  - (3) Netting sometimes requires divers, but with new systems developed by Australian Bluefin Pty Ltd, diving is not necessary.
  - (4) However, with netting it is difficult to precisely estimate the numbers harvested, so affecting freight and processing schedules. Note that bigger operators have no difficulty handling this.
76. The techniques used on the research farm (*Figure 26* ) were:
- (1) Harvest of around one tonne usually took 5-6 operators for fishing, diving, gaffing, gilling and gutting or other processing, scaring birds, etc. The gaffs used were stainless steel 8mm diameter, 35-40cm long. The fish were gaffed in the head (except in the gill covers). The blood-draining spike was inserted 5-7cm behind the root of the pectoral fins on both sides.
  - (2) Catching was by poling and line. Killing was by spiking and the blood drained by cutting behind the base of both pectoral fins. The spikes used were stainless steel, 10mm diameter, 35-40cm long. Since then the spiker has been improved, including use sometimes of a serrated edge (see *Figure Twenty Seven* ). Fish were then put in the cooling tanks. On the research farm traditional methods were used. On harvest day a two-tonne FRP cooling tank was prepared using 20kg bags of crushed ice (around 200kg total) and 12kg or rock salt, followed by 1.2 tonnes of pure water, and circulated with a recirculating pump (180 l/m) with a sprinkler-type nozzle attached. The slurry used to cool the harvest fish was generally at 12 to 15° C . Four to five hours after harvest, the water was exchanged to avoid possible freezing and to eliminate accumulated blood and slime. The fish were cooled for 24-28 hours before processing - with body temperature around 0.8-1.2° C. (*Figure Twenty Eight* measures the changes in the body temperature of two sample fish).

- (3) At the processing plant, measurements were taken of the fork length, body weight and body temperature. Again traditional processing methods were used. A knife was inserted in the anus and cut about 5-10cm towards the vertical fins - ensuring a clean cut with no ragged edges. The fingers were used to pull out the intestines which were cut off at the root to ensure nothing remains. Testes or ovaries can often stick to the roof of the anus, and were always removed to ensure freshness. The gill covers were then opened wide and a cut made through the central membrane of the gills and internal organs from the head to the rear of the mouth, following the line of the gill cover. An air filled drill fitted with a nylon brush head (No. 150 to 250 gut) was used to clean around the interior of the gill covers, rinsing with water at the same time. The belly and gill cavities were then washed in a water-ice pool, using a cloth to remove slime and excess moisture. The fish were then packed one or two to a box, with one or two 500-600g bags of ice into the gill cavity.
- (4) As the emphasis is on reducing the temperature of the fish at a fast but consistent pace, different processing methods are continually tried. It is still not clear whether full or part gill and gutting on the grounds is the best approach. Part processing on site (including bleeding), overnight cooling and then full processing next day, is the method practiced by some farmers. Others process almost fully on the grounds. In both cases all waste is carried to shore.
- (5) Typical times from harvest to market during the research project are outlined in *Table Ten*.

## Product Quality

### Meat Quality Data

77. Between August 1991 and May 1993, seven meat quality analyses were carried out on a farmed SBT and compared with two wild samples. The tests were carried out by the Japan Frozen Foods Inspection Service. The experiment followed the procedures from the Japan Foodstuffs Standard Composition Tables. The exception was the metmyoglobin analysis, based on the Simplified Bito Method from the Tokai Regional Fisheries Research Laboratory Bulletin (1976). The K value was determined by colour chromatography (pers. comm. Koga).
78. The normal sampling portions for SBT and NBT are shown in Figure Twenty-Nine. *Table Eleven* shows the standard official constituents in Japan for SBT and NBT. *Table Eleven* summarises all the results of the tests. The comments on the data are in the following paragraphs.

Fig. 26 Sketch of final harvesting from pontoon nets

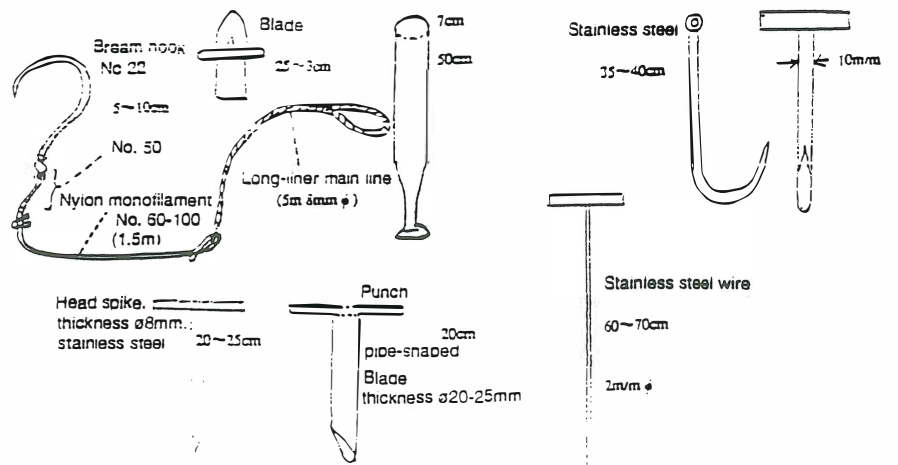
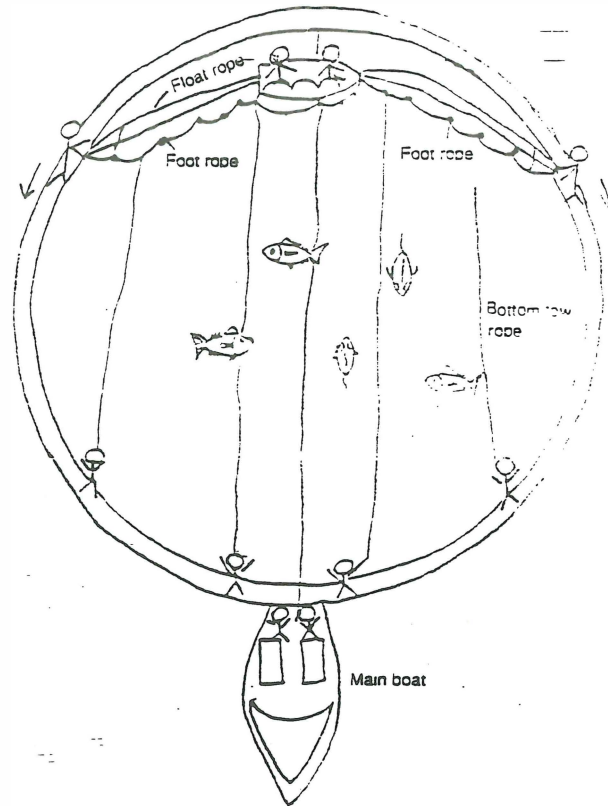

Fig. 27 Tools needed for harvesting

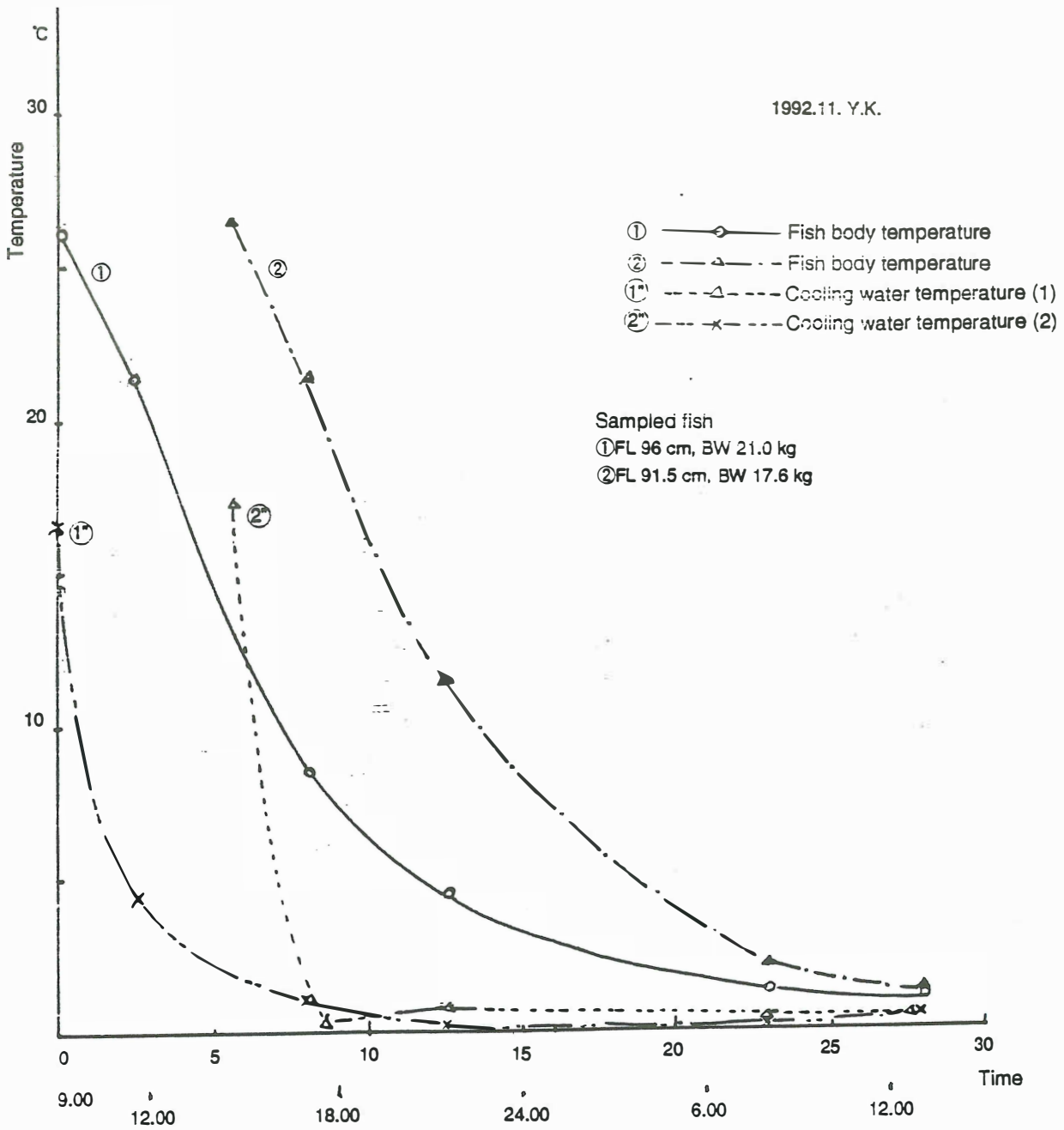

Fig. 28 Changes of fish body temperature during iced water cooling (Nov. 1991)

**TABLE 10****Research Farm Experience of Harvest/Market Schedules**

Process	Aug. 1991-Nov. 1992			Nov. 1992-May 1993			Comment
	Day	Time	Time Taken	Day	Time	Time Taken	
Harvesting	One	9-11	2	One	9-11	2	
Cooling		11-14	3	Two	11-14	27	
Processing/ Packing		14-15	1		14-15	1	
Cold Storage		15-17	2	15-17	2		
Road Freight	Two	17-13	20	Three	17-13	10	Syd/Tokyo
Air Freight	Three	22-08	10	Four	22-08	10	Syd/Tokyo
Customs (Narita)		08-12	6		08-12		
Market	Four			Five			Various Japan

Source: OFCF Experts

79. **Moisture Content:** *Figure Thirty* shows the seasonal changes in moisture content and lipid level for farmed tuna - showing a clear inverse relationship. During the period when lipids accumulate, moisture content falls. In many cases the two values sum to between 70-80 per cent. The trend is similar to NBT observations (pers comm. Koga).
80. **Protein Content:** Compared with the *Standard Composition Tables* the variations between the akami and toro parts are significant, overall greater than the Tables. Wild-caught SBT had a higher protein content than the early farmed SBT
81. **Lipid Levels:** These vary between 0.6 per cent and 27.6 per cent. These lipid levels are roughly equivalent to the levels of the oil in NBT. For farmed SBT there are significant seasonal variations in lipid levels - with differences within summer, and higher average oil levels in winter. Unfortunately the number of tests did not allow definitive conclusions.
82. **Carbohydrates (sugars):** The SBT farm levels varied between 0.1 and 1.4 per cent compared with 0.1 per cent in the wild tuna *Composition Tables*. The difference is presumably due to the much shorter time (30-60 seconds) between capture and kill of farmed SBT. Rapidly killed fish consume little glycogen, and therefore sugar levels remain high.
83. **Freshness Indicators (K Levels):** K level is the measurement commonly used for freshness measuring. Adenosine triphosphate (ATP), a chemical dispersed throughout the muscle fibres of fish, has a number of crucial biochemical roles. Immediately after death, ATP decomposes successively through enzyme action to adenosine diphosphate (ADP), adenosine monophosphate (AMP), inosinic acid (IMP), inosine (HxR) and hypoxanthine (Hx). Therefore, if we know how much ATP has decomposed, we can measure the time elapsed since the fish's death (ie. freshness). The degree of decomposition of ATP, or alternatively, the level of accumulation of the decomposition products HxR and Hx, is represented by the K value shown below.

$$\text{K value percentage} = \frac{\text{HxR} + \text{Hx}}{(\text{ATP} + \text{ADP} + \text{AMP} + \text{IMP} + \text{HxR} + \text{Hx})} \times 100$$

In short, as freshness drops, so do the ATP, ADP, AMP and IMP concentrations whereas the HxR and Hx values rise, thus making the K value higher. Comparing the K values for farmed SBT with other marketed tuna produces the following results:

Farmed SBT (Tokyo Market)	7.8-17.8 %
Top quality tuna (Tokyo Market)	0-35 %
Commercially available sashimi	0-37 %

84. The K value deteriorated when the new processing methods were adopted. From August 1991 to end October 1992 the SBT were cooled for four to five hours on the day of harvest, then processed, packed and shipped. From late 1992, they were cooled for 24-28 hours after harvest and then processed.

**TABLE 11**

**Standard Constituents of Northern and Southern Bluefin  
as Provided in Japan Food Standard Constituent Tables  
(g/100g of edible parts)**

<b>Item</b>	<b>Moisture</b>	<b>Protein</b>	<b>Lipid</b>	<b>Carbohydrates</b>	<b>Ash</b>
<b>Type</b>					
NBT (red meat)	68.7	28.3	1.4	0.1	1.5
NBT (fat)	52.6	21.4	24.6	0.1	1.3
SBT (red meat)	65.6	23.6	9.3	0.1	1.4
SBT (fat)	63.9	23.1	11.6	0.1	1.3

*Source: From 4th Revision Japan Food Standard Constituent Tables*

**Fig. 29** Portions sampled for muscle specimens in meat quality tests (excluding bone, skin, and red muscle)

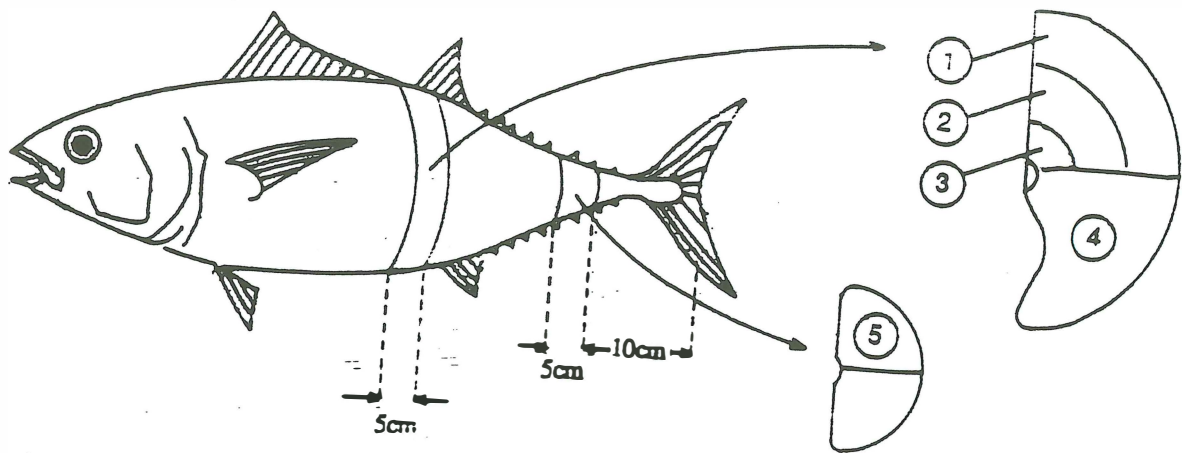



**Table 11**

Meat quality constituent analysis results for farming-reared southern bluefin tuna

Test Item	Date & Weight (g.g.)	1991.8.27 12kg					1991.8.27 14.0kg				
	Test Portion	(1)	(2)	(3)	(4)	(5)	(6)	(7)	(8)	(9)	(10)
Moisture g/100g		57.6	63.5	67.7	-	-	58.5	63.5	68.1	-	-
Protein g/100		22.8	27.4	28.3	-	-	23.4	27.4	27.9	-	-
Lipid g/100		18.2	7.6	2.5	10.7	6.5	16.8	9.6	2.4	4.3	9.9
Carbohydrates	Non-fibrous g/100g	0.3	0.3	0.3	-	-	0.3	0.3	0.3	-	-
	Energy kca/100g	0	0	0	-	-	0	0	0	-	-
Ash g/100		1.1	1.2	1.2	-	-	1.0	1.2	1.3	-	-
Energy kcal/100g		269	188	144	-	-	258	180	142	-	-
K value %		-	7.8	-	-	-	-	9.4	-	-	-
The Metmyoglobin to Total Myoglobin Ratio %		22.0	20.5	24.0	-	14.5	13.5	15.0	18.5	-	27.5

**Table 11 Cont.**

Test Item	Date & Weight (g.g.)	14.4kg					18.8kg				
	Test Portion	(1)	(2)	(3)	(4)	(5)	(1)	(2)	(3)	(4)	(5)
Moisture g/100g		55.9	65.0	68.4	-	-	61.8	69.9	70.4	-	-
Protein g/100		23.4	26.1	28.0	-	-	24.7	27.2	27.1	-	-
Lipid g/100		19.4	7.4	2.1	4.9	7.0	11.8	1.2	0.6	7.4	4.4
Carbohydrates	Non-fibrous g/100g	0.3	0.2	0.2	-	-	0.5	0.4	0.5	-	-
	Energy kca/100g	0	0	0	-	-	0	0	0	-	-
Ash g/100		1.0	1.3	1.3	-	-	1.2	1.3	1.4	-	-
Energy kcal/100g		283	181	139	-	-	217	128	122	-	-
K value %		-	9.1	-	-	-	-	10.1	-	-	-
The Metmyoglobin to Total Myoglobin Ratio %		21.5	25.5	24.0	-	22.5	40.5	32.0	31.3	-	41.0

**Table 11 Cont.**

Test Item	Date & Weight (g.g) Test Portion	1991.12.10 19.0kg					1992.2.11 24.2kg				
		(1)	(2)	(3)	(4)	(5)	(1)	(2)	(3)	(4)	(5)
Moisture g/100g		62.9	69.9	71.3	-	-	64.9	70.0	71.2	-	-
Protein g/100		24.1	27.2	26.6	-	-	22.9	24.6	23.6	-	-
Lipid g/100		11.7	1.3	0.7	10.9	5.2	9.2	2.2	1.5	7.3	4.7
Carbohydrates	Non-fibrous g/100g	0.2	0.3	0.1	-	-	0.5	0.9	1.2	-	-
	Energy kca/100g	0	0	0	-	-	0	0	0	-	-
Ash g/100		1.1	1.3	1.3	-	-	2.5	2.0	2.5	-	-
Energy kcal/100g		213	128	119	-	-	185	128	119	-	-
K value %		-	8.1	-	-	-	-	11.5	-	-	-
The Metmyoglobin to Total Myoglobin Ratio %		32.5	23.5	26.0	-	47.0	39.0	33.5	36.0	-	38.5

**Table 11 Cont.**

Test Item	Date & Weight (g.g.)	1992.3.10 22.8kg					1992.12.22 14.2kg				
	Test Portion	(1)	(2)	(3)	(4)	(5)	(1)	(2)	(3)	(4)	(5)
Moisture g/100g		60.2	67.8	69.9	-	-	56.7	65.4	69.2	-	-
Protein g/100		22.8	26.0	24.4	-	-	20.2	25.6	26.8	-	-
Lipid g/100		14.0	4.0	3.0	10.6	7.4	21.9	7.6	2.6	27.6	14.7
Carbohydrates	Non-fibrous g/100g	0.5	0.8	1.3	-	-	0.2	0.2	0.2	-	-
	Energy kca/100g	0	0	0	-	-	0	0	0	-	-
Ash g/100		2.5	1.4	1.4	-	-	1.0	1.2	1.2	-	-
Energy kcal/100g		230	151	137	-	-	292	180	138	-	-
K value %		-	14.2	-	-	-	-	-	-	-	-
The Metmyoglobin to Total Myoglobin Ratio %		26.5	29.0	24.5	-	41.0	30.8	30.5	29.0	-	33.0

**Table 11 Cont.**

Test Item	Date & Weight (g.g.) Test Portion	1992.12.22 27.6kg					1993.4.26 17.0kg					1993.4.26 29.6kg				
		(1)	(2)	(3)	(4)	(5)	(1)	(2)	(3)	(4)	(5)	(1)	(2)	(3)	(4)	(5)
Moisture g/100g		56.5	66.2	69.7	-	-	65.4	69.6	70.4	-	-	62.0	66.9	69.3	-	-
Protein g/100		21.2	26.2	26.5	-	-	24.5	26.7	27.2	-	-	23.0	25.6	25.9	-	-
Lipid g/100		21.2	6.2	2.2	27.5	13.3	7.3	2.1	0.7	4.9	0.4	13.0	5.8	3.0	7.5	3.8
Carbohydrates	Non-fibrous g/100g	0.2	0.2	0.3	-	-	1.4	0.3	0.3	-	-	0.6	0.3	0.3	-	-
	Energy kca/100g	0	0	0	-	-				--	-					
Ash g/100		0.9	1.2	1.3	-	-	1.4	1.3	1.4	-	-	1.4	1.4	1.5	-	-
Energy kcal/100g		290	170	134	-	-	178	134	123			222	164	139	-	-
K value %		-	-	-	-	-	-	14.9	-	-	-	-	17.8	-	-	-
The Metmyoglobin to Total Myoglobin Ratio %		34.7	38.7	47.5	-	42.5	41.1	37.3	64.5	-	71.7	56.9	48.5	62.9	-	68.8

**Fig. 30** Seasonal changes in farmed southern bluefin tuna moisture (portion 1) and lipid (portions 1 and 4) (1991-93)

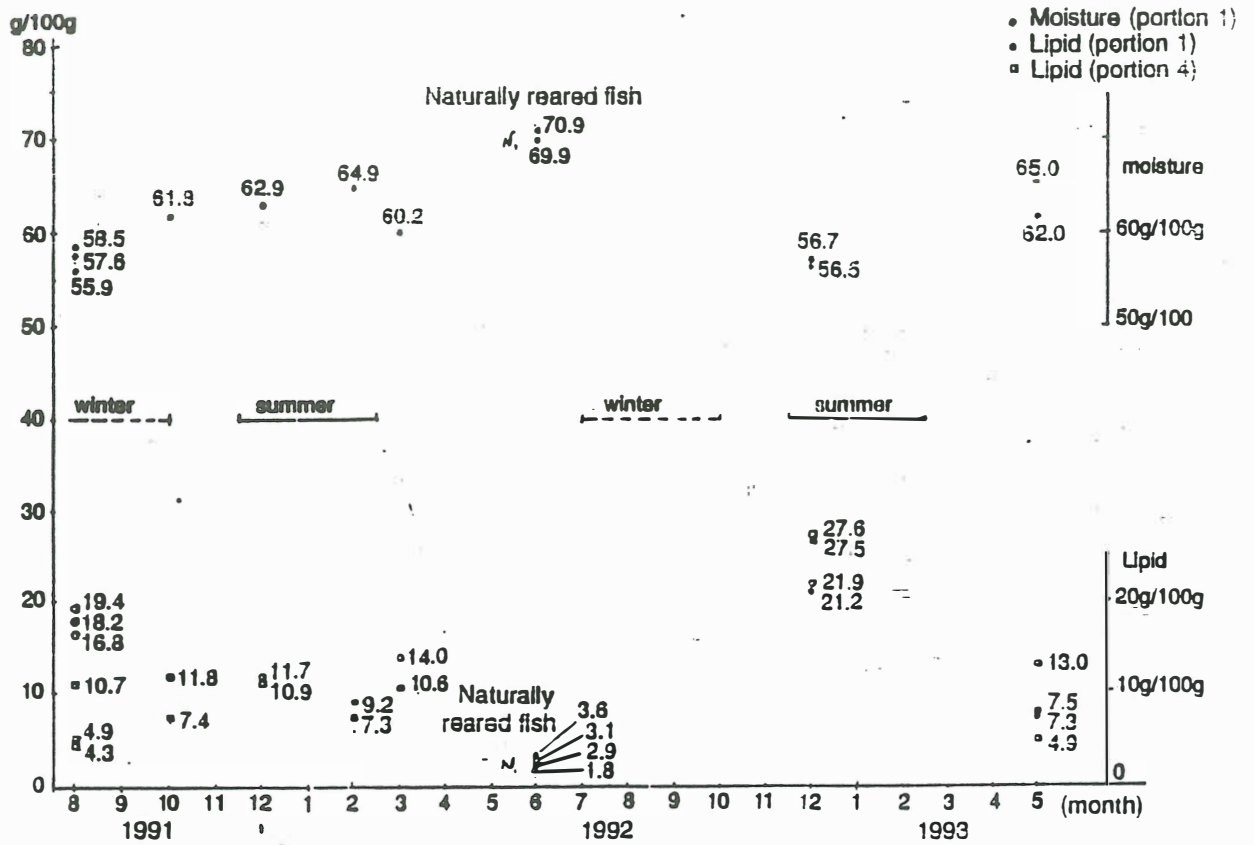

85. **Meat Colour** (Metmyoglobin formation): The muscle fibre pigment myoglobin (Mb) combines with oxygen in the atmosphere to form oxymyoglobin (MbO<sub>2</sub>) to give meat its brilliant red colour. However, if exposed to the air for a long time, MbO<sub>2</sub> is oxidised to form metmyoglobin (metMb) and the flesh colour changes to an unacceptable brown or blackish brown. The ratio of metmyoglobin formation represents the ratio of metMb compared with the total Mb.
86. *Figure Thirty One* shows a graph of the rate of formation of metMb for NBT (2 x 2 x 4cm strip) over a period of 5 days. This is close to the time it takes to deliver farmed SBT to the market after harvest. When the values for farmed SBT are assessed the results were good, except for one sample on 30 April 1993.

### **Farmed SBT - Questionnaire Results**

87. The test was on 5 September 1991 using a range of experts in Japan.
88. Extra to the attached questionnaire results (see *Attachment Six* ) the experts made the following comments:
- (1) **Colour:** 69 per cent answered good or very good on the akami with 9 per cent assessing it as pale. *Note* : The proportion of akami in farmed SBT is low compared with wild-caught SBT, though this gap narrows with fish size.
  - (2) **Oiliness:** 80 per cent answered good or very good, surprisingly high for smaller SBT. Some of the experts thought that the oil level was too high and heavy.
  - (3) **Texture:** 72 per cent answered good or very good. The 7 per cent judging it as poor assessed it as lacking a defined shape when it was cut into sashimi pieces and was too soft.
  - (4) **Freshness:** The experts knew about the short time between harvest and tasting - it is no surprise that 80 per cent assessed freshness as good or very good.
  - (5) **Overall:** 81 per cent assessed the quality as good or very good with no responses of poor or very poor.
89. Subsequent experience has been that high fat gain in summer has inevitably produced a paler meat, particularly compared with wild-caught SBT and wintered farm fish. At this stage there is no real indication that bigger fish have better colour. Therefore when frozen wild-caught SBT is compared with farmed SBT, the latter is preferred on oiliness and freshness, but frozen rates better colour.

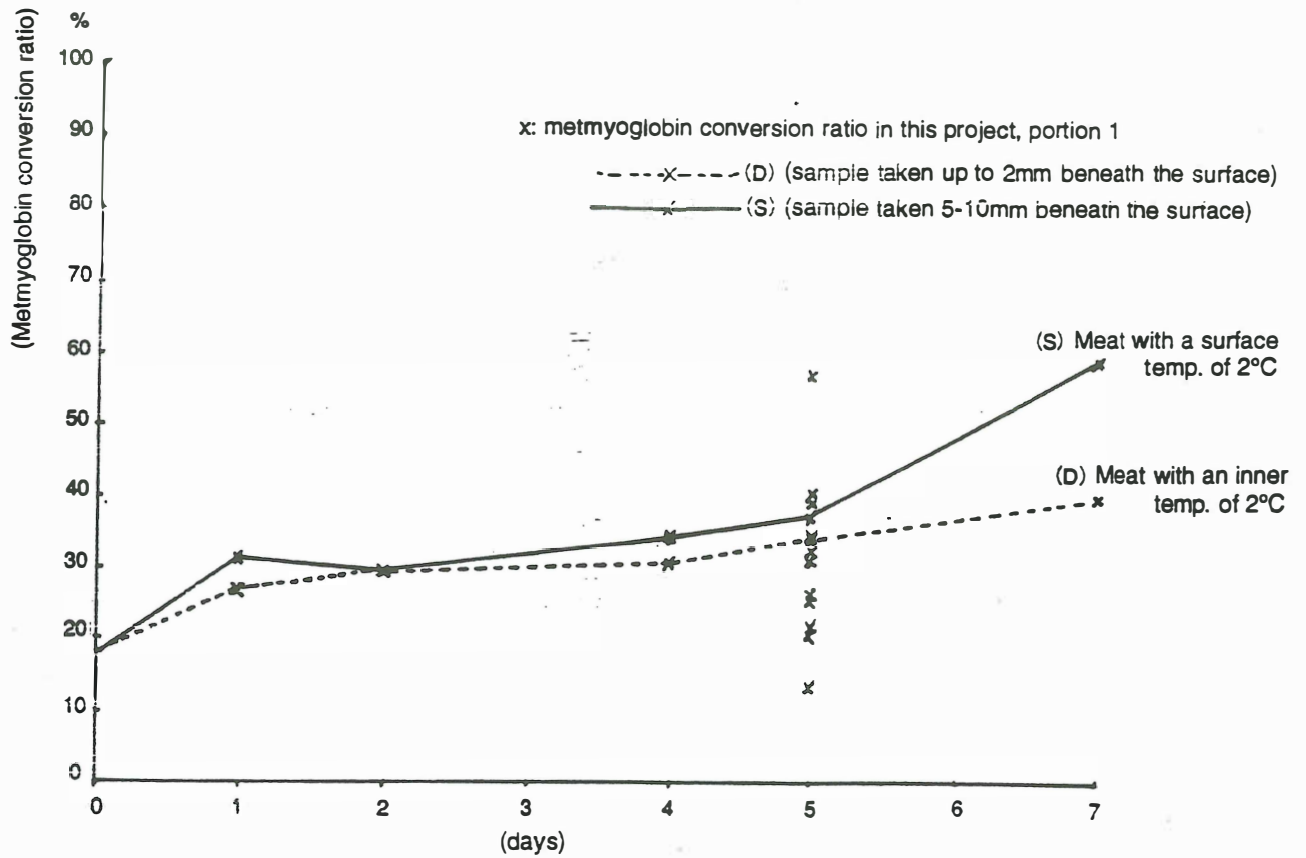

**Fig. 31** Time-lapse changes in the metmyoglobin conversion ratio of bluefin tuna stored at 2-30°C (except from Bito, 1976), and the metmyoglobin conversion ratio on the 5th day in portion 1 of southern bluefin tuna shipped in this project



## Management Issues

### Fish Health

90. During the project, and subsequently, there has been no evidence of serious health problems. Despite this the ATBOA has employed a full-time scientist on fish health to develop a long-term data base and respond to any crises.
91. During 1991 and 1992, of the 1,006 fish marketed, only 5 were reported to have the parasite kudoa (ie. 0.5 per cent), thought to be the most common parasite in tuna. It is not clear whether this is any different from wild-caught tuna because of the lack of data. However, subsequent surveys of farmed SBT showed:
- (1) Fish caught inshore off Port Lincoln (eg. Rocky Island, Cabbage Patch ) have a much higher incidence of parasites, including kudoa. All the experimental farm fish came from inshore.
  - (2) The incidence of parasites decreases with time in the farm (*Rough 1994* ). The exact reason for this is not yet clear, though it is thought to reflect freezing of the feed killing feed pilchard parasites. This is important when the incidence of heteraxiniasis and benedeniasis in the wild is considered (*Rough 1994* ).
92. Experience in Japan has emphasised the importance of vitamin supplements in fish health. In Australia, supplements of vitamins C, B, and E are particularly important as they are lost through oxidation of frozen pilchards.

### Predators

93. The only continuing incidence of "predators" during the research project was smaller species eating feed. These include Tommy ruff (*Arripis georgianus* ), Australian salmon (*Arripis trutta* ), White trevally (*Caranx nobilis macleay* ), Yellowtail (*Trachurus declivis* ). These species entered the nets when small and could not escape as they grew. Tommy ruffs were 6-7cm when they entered the pontoons and within a year had grown to 23-27cm, weighing 300-350g. Species such as Australian salmon and Tommy ruff possibly ate up to 4 per cent of feed.
94. Inside 2 years, one pontoon had an estimated 2-3 tonnes of tommy ruffs. Periodic netting produced 500kg on the first shot but it was difficult to catch more than 10-20kg per shot after that. One Port Lincoln company experimented with hand-line fishing of Tommy ruffs - about 20kg/time - and sent them for smoking. This experiment was stopped by marine scale fishery regulations.
95. The Australian salmon swam into the nets at around 20cm, became 1-1.5kg in 12 months and 4-4.5kg in two years. When small they try to catch the pilchards on the surface but once reaching 500g they tend to swim around the bottom of the pontoon, feeding on leftovers. One operator actually introduced large salmon into the nets to feed on the small Tommy ruffs.

## **Birds**

96. Seagulls and terns tend to disrupt feeding. In 1991, a 3-4mm thick polypropylene rope was strung through the rings at the top of the pontoon to discourage birds from diving into the water - but the birds quickly became used to this. Next a bird-proof net was tried but discontinued because when the supporting rope was tensed, the top rings of the pontoon frame bent.
97. The commonly used device is now a five metre bamboo pole with a thin nylon rope (4-5mm) attached. Using it in a whipping action creates a noise which drives the birds away. While this is safe and effective, it is labour intensive.

## **Sales of Tuna**

98. The experimental sales began in August 1991 and were periodic up until the end of the project. The initial prices were high, particularly for small fish (under 20kg) and it was difficult to separate the underlying trend from the novelty, and seasonal changes.
99. Prices for research farm fish generally dropped in 1992 to around Y3,500/kg as product was introduced from follow-up operations in Port Lincoln. Prices again dropped in 1993 as volume increased. However, larger fish clearly brought a higher price. *Attachment Seven* is a typical sales report for the research farm fish.
100. Prices have continued to fall as volume increased but appear to have stabilised around Y2,500/kg average in 1996 and 1997. This reflects a mixture of points:
  - (1) An increase in quality to significantly offset the big volume increases.
  - (2) Much earlier and larger marketings in the first half of the year, to spread sales over more months.
  - (3) Very strong domestic tuna catch in Japan in some years.
  - (4) Increasing competition from areas such as toro blocks from Indonesia, and Tunisia, and farmed tuna from the Mediterranean and North America.
101. It is therefore again very difficult to identify the long-term price trend for farmed SBT. The quality, size and market changes are moving so fast that it will probably be 1998 or 1999 before a benchmark price can be established. What is clear is that the quality (including size) of Australian farmed tuna is improving substantially each year, and that the market is preferring fresh fish to traditional Japanese caught frozen SBT and NBT. What is also clear is that there are large differentials between prices received by different Australian farms. This indicates the potential to considerably lift the average price.

## Environmental Management

102. This section draws directly on work developed for the ATBOA on the research and for the *Port Lincoln Aquaculture Management Plan (Bond, 1993)*. Under its licence the ATBOA committed to a comprehensive environmental monitoring program. This has continued beyond the initial experiment and is now conducted across all farms by a team from the SA Research and Development Institute (SARDI). The industry contributes over \$200,000 per annum to this program.
103. It is generally accepted that finfish farming requires continuous monitoring of stocking rates and the environmental impact. Under the very conservative stocking standards of the Management Plan governing SBT farming, the fish aggregation rates are probably no higher than in the wild. However, the pontoons are in a static position, and the feeding rates are higher in farms than in the wild.
104. When tuna farming was developed, the large majority of studies on the impact of finfish farming on the environment was for salmonids. Much of that was also based on operations using pellets, and based in freshwater.
105. These previous studies identified the main ways in which tuna farming could impact on the environment. These all need to be continuously studied, and included:
- (1) The effect of waste products on the bottom (sediment) and biota, both underneath and away from the pontoon.
  - (2) The impact on dissolved oxygen levels.
  - (3) The more general effects of nutrients on the water quality in the area.
106. In general, waste nitrogen compound and organic carbon are the wastes generally considered to have the greatest impact (*Bond 1993*). In soluble form they can be excreted in urine and via gills, or particulate form (eg. uneaten food, mucous, faecal pellets) or material leached from solids as it sinks.
107. Studies in Scotland on salmonids have estimated that 50-80kg of dissolved oxygen is produced per tonne of fish production each year (*University of Stirling 1988*, as reported in *Bond, 1993*). *Bond 1993*, also notes that a number of studies in Norway, the United States, Ireland and Scotland have reported localised increases in ammonia at farm sites (*Gowen and Bradbury 1987, University of Stirling 1988*). In Norway, studies at six farm sites reported total ammonia and inorganic phosphorous concentrations at the cages of 8 to 9 times background, to a level of 70ug/l.
108. Overseas experience (*Bond 1993*) has been that such elevated levels of nutrients are very localised (within 50 to 100m of the pontoons) and there was no evidence of widespread nutrient enrichment from sea-pontoon operations in open water bodies. Woodward et al. (1991) - from *Bond 1993*, concluded that there was no evidence to suggest that the accumulated fluxes of nutrients from pontoons in the Huon estuary in Tasmania contribute to eutrophication, and phytoplankton levels in the pontoons were well within

the normal ranges for southwest Tasmanian waters. Similarly *Gowen and Bradbury* (1987) concluded that there was no evidence to suggest that the occurrence of toxic phytoplankton blooms in Scotland and in Norway are related to fish farming (*Bond 1993* ).

### **Port Lincoln Nutrient Studies**

109. Background nutrient levels in Boston Bay were known to be elevated, presumably largely by the untreated effluent sewage discharge from the Billy Lights out fall (*Bond 1993* ). This was treated from 1993. However, before that the Engineering and Water Supply Department (EWS) had identified the nutrient levels in *Table 1* below (*Bond 1993* ).

#### **Nutrient Levels in Boston Boston Bay (1979-1986)**

<u>Parameter</u> (mg/l)	<u>Outfall</u>	<u>North Shields</u> (closest to Research Farm)
Tot-P	0.064-0.147	0.018-0.023
NH <sub>3</sub> -N	0.140-0.249	0.017-0.025
Ox-N	0.010 (1)	0.010 (1)
TKN	0.530-1.070	0.220-0.610

*Source: Engineering and Water Supply Department (1989) from Bond 1993*

(1) Lowest detectable concentration

110. Results (*Bond 1993* ) from the Research Farm and one commercial farm suggest an increase in TKN and ammonia within the pontoons and up to 25m from the pontoon.

	<u>Pontoon Area</u>	<u>Control Area</u>
TKN (MG/L) (1)	0.19-0.64	0.15-0.36
NH <sub>3</sub> -N (1)	0.018-0.11	0.017-0.035
NH <sub>3</sub> -N (2)	0.13	0.084

*Source: Various (from Bond 1993)*

(1) Research Farm  
(2) SA Marine Farm area

111. These research data are supported by modelling done during the Project, and since, by Petrusевичs (see *Bond 1993* and below). Petrusевичs based loadings and diffusion on actual commercial feeding rates and oceanographic work.

112. Petrusevics (*Bond 1993*) estimated nitrogen loading in the water column from a single pontoon. Using a feed rate of approximately 270 tonnes per 8 months, production of 13 tonnes and assuming a 3 per cent conversion of waste to protein nitrogen, a nitrogen concentration of about 1.3 mg l<sup>-1</sup> (neglecting diffusion) was calculated within the volume of the pontoon and its projection to the seabed. Note that Petrusevics use of an FCR of 20:1 was different from current (1995) rates of around 15:1 because of the evolution towards feeding over higher weight gain summer months (see below).
113. Taking into account diffusion/dispersion, Petrusevics (*Bond 1993*) calculated the total nitrogen concentration in a single pontoon using the one dimensional diffusion and advection equation. Based on an advection rate of 5 cm s<sup>-1</sup>, diffusion co-efficient of 0.9 m<sup>2</sup> s<sup>-1</sup> and dilution factor of .002 the total nitrogen concentration at a distance of 1000m was calculated to be about 0.003 mg l<sup>-1</sup> at a distance of 100m and 50m the dilution factors are approximately 0.006 and 0.009, and the total nitrogen concentrations are 0.008 and 0.012 mg l<sup>-1</sup> respectively.
114. Petrusevics (1996) has more recently modelled the area inside the western side of Boston Island.

### **Phytoplankton**

115. In the first two years of the research farm roughly the Project period, there were no problems with phytoplankton blooms in the vicinity of the Research Farm (*Bond 1993*) and chlorophyll (a) levels in the vicinity of the tuna operations have been of no concern (0.21 - 1.26 ug/l). Cysts of the toxic dinoflagellae *Alexandrium minutum* have consistently been found in the sediments around the main wharf (*Hallegraff 1995*) and the only reported phytoplankton bloom in the study area was of this species at the main wharf. Clarke (*Bond 1993*) notes that the localised nature of that bloom and its location suggests that it may have been linked to ballast water discharge, which has been shown to be one of the principal methods by which such cysts are transported around the world.
116. Clarke (*Bond 1993*) further notes that more frequent or widespread blooms of dinoflagellates (*Alexandrium minutum*) in the study area were not expected as some of the crucial physio-chemical conditions conducive to large scale germination (salinities 14-26 ppt) and proliferation (stable/stratified water column with little mixing) are not present. However, Clarke noted that insufficient information existed to be certain of the effects of aquaculture on all species of phytoplankton.

### **Impact of Particulate Organic Matter**

117. In *Bond 1993*, it is noted that the main impact of sea-pontoon operations on the marine environment are the changes brought about to the physio-chemical and biotic characteristics of the sediments within the vicinity of the pontoons by the particulate organic wastes.

118. **Physio-Chemical Changes:** In *Bond 1993*, it is noted that under natural conditions marine sediments consist of an overlying aerobic (oxygenated) zone and an underlying anaerobic zone. The depth of the interface between the two is dependent on the balance between the consumption of oxygen by heterotrophic organisms (principally bacteria) and the supply of oxygen through diffusion and bioturbation. As the supply of organic material to the sediments increases, so too does the respiratory requirements of the benthic organisms that break down such material. With continued organic input the oxygen demand of the sediments will eventually exceed the oxygen supply and the depth of the aerobic/anaerobic zone will diminish until the sediments become oxygen deficient or anoxic.
119. At this stage (1996), there is no evidence of oxygen demand from sediments becoming anoxic
120. **Benthic Community Changes:** In *Bond 1993*, it is noted that the first impact on benthos of organic enrichment is an increase in the bacterial biomass and productivity. As enrichment continues the number of species within the benthos decreases. Literature on other species indicates usually a gradient effect of organic enrichment on the benthos, with there being an azoic zone organisms remain, an opportunistic zone restricted to the immediate vicinity of the pontoons (up to 30m from the site), and a return to background communities over 30m from the pontoons. Occasionally impacts on the benthos were identified up to 100m away from pontoons.
121. Field studies during the Project period to assess benthos changes utilised sediment traps and photographic techniques (*Bond 1993*). Sedimentation rates of up to 4.6 times that of control areas have been recorded directly under pontoons at the Research Farm, and between 2.2 and 6.6 times that of control areas for the commercial Lincoln Marine Farm Pty Ltd, depending on stocking rates. A gradient effect on benthic communities was evident with distance from the pontoon centre in any one operation. The observable density and diversity of pre-stocking communities was reduced most notably directly beneath the pontoons with highest stocking levels (<2kg/m<sup>3</sup>) but the detectable changes stopped within metres of the edge of the pontoon.
122. Subsequent research (*Cheshire et al 1996*) showed higher ranges of impact as follows. In general the epibenthic communities were impacted up to 150m from the pontoons. Surveys at 200m indicated that epibenthic communities were not different from those on the control transect. Effects on infaunal communities were significant within 20m of the pontoons.
123. **Seafloor:** The effect of the farms on the seafloor was monitored using sediment collectors, underwater photography and sediment samples.
124. The data from the sediment collectors indicate that the area in which the research farm was located was characterised by deposition levels of 10-20 g/m<sup>2</sup>/day. Deposition rates were about six times greater than background levels beneath the pontoons, but returned to normal within 20-40m of the perimeter of the pontoons. Note that the data obtained did not included the whole pilchards fed to the tuna which were sometimes seen decomposing on the seafloor, but did include substantial amounts of material from the plant and animal communities which colonise the predator and fish nets used on the farm.

125. The data on sediment accumulation from in situ measurements on the seafloor were considered unreliable because of the techniques used and farm management practices applied over the sampling period. Visual observations, however, indicated that sediments did accumulate below the pontoons, particularly near the nets at the perimeter. Contact between the predator net and the seafloor can lead to occasional erosion and sorting of these sediments.
126. Photographic data and in situ observations by divers indicated that the sediments in the area of the research farm naturally have only a shallow aerobic layer at the surface and became progressively more anoxic beneath the pontoons. Data from chemical analysis of sediment samples suggest that total organic carbon, total phosphate and total kjeldahl nitrogen increased with time below the pontoons.
127. **Fauna and Flora:** Photographic data and in situ observations by divers indicated that a relatively low diversity plant and animal community characterises the deeper, silty environment where the pontoons were sited. This community, dominated by moderate cover of the heavily epiphytised red alga *Botryocloida obovata*, was substantially impacted under and adjacent to the sea-cages. Initially, the percent cover of red alga decreased, and the abundance of a number of opportunistic species (eg. tubeworms, holothurians, and the green alga (*Ulva sp* )) increased. Within six to twelve months from initiation to farming operations the area beneath the pontoons was devoid of macro flora and fauna except for spider crabs which were abundant. The recorded impacts probably resulted from a combination of factors: a reduction in light due to the pontoon nets and the accumulation of fouling organisms on them, the deposition of organic matter which creates anoxic sediments, and physical damage from contact between the predator net and the seafloor.
128. In summary (*Bond 1993* ), the sedimentological data shows that the effects of the research farm were pronounced beneath the pontoons and decreased rapidly with increasing distance away from the cages. In general, the effects of the farm were not detectable beyond about 40m from the centre of a sea-cage. While the natural assimilative capacity of the seafloor is exceeded beneath the sea-cages, the scientific literature on the topic suggests that management procedures such as seafloor fallowing will satisfactorily maintain the quality of the site in the long term.
129. **Water Column:** Hydrology: A multisensor data logger was deployed on two separate occasions to record direction and speed of water movement (*Bond 1993* ). The data obtained confirmed visual indications that tidal currents were strongly influenced by local winds, often diurnal in nature, primarily from the south west and north west, and on average less than 2cm/sec in speed. Such current speeds are low and are unlikely to disperse material settling to the seafloor. In situ observations by divers suggested that the choppy wave conditions often experienced at the sea surface do not cause re-suspension of seafloor sediments.

130. **Water Chemistry:** The near surface water quality data collected in the vicinity of the tuna research farm was based on the measurement of total (TP) and soluble phosphate, total kjeldahl nitrogen (TKN), ammonia, nitrate and nitrite (*Bond 1993* ). The data collected supported E&WS information in indicating that nitrogen and phosphate levels in Boston Bay are higher than for most coastal South Australian waters.
131. The data also suggests that the research farm on occasions has elevated ammonia, total kjeldahl nitrogen soluble phosphorus and total phosphorus concentrations within the pontoons (about twice background levels on TKN and TP) and to a lesser degree to about 40m from the centre of the cages. Trends are however, masked to a degree by inter-sample variability and differences between sampling times (*Bond 1993* ).
132. Data on near-surface dissolved oxygen, pH and turbidity did not reflect any trends which could be attributed to the farm (*Bond 1993* ).
133. Chlorophyll data was collected to evaluate the prevalence of phytoplankton in surface waters. In general, chlorophyll levels in Boston Bay were found to be low (about 0.2-0.7 ug/l), to vary spatially and temporally, and to apparently be unaffected by the research farm (*Bond 1993* ).
134. In summary, the water column in the vicinity of the sea-cages (to about 40-60m from the centre of the cages). is characterised by elevated nutrient levels and an increased diversity and abundance of fauna, which is in contrast to the notable decline of macro organisms on the seafloor (*Bond 1993* ).
135. **Chemicals:** No anti-fouling compounds were used on the pontoon nets during the period that the tuna farm was monitored, nor were any drugs used for therapeutic or prophylactic treatments of fish (*Bond 1993* ).
136. **Conclusion:** Data from four sampling occasions, distributed over approximately 18 months, suggest that the research farm had a pronounced but localised effect on the seafloor, and a relatively minor localised effect on the water column. These findings are in general agreement with the international scientific literature on the effects of finfish pontoon culture on the marine environment (*Bond 1993* ).

### **Environment Impacts of Nutrients from Tuna Farming in Boston Bay**

137. **Introduction:** Nutrient enrichment of Boston Bay due to dissolved nitrogen compounds produced by farming tuna and microbial breakdown of faecal matter and unconsumed food, is of concern since it may impact upon the seagrass and benthic faunal communities of the Bay (*Bond 1993* ).
138. Studies of treated sewage discharges to Gulf St Vincent from wastewater treatment plants (WWTP) had demonstrated a correlation between predicted water column concentrations of nitrogen compounds and the decline of *Amphibolis sp* and *Posidonia sp* seagrass communities (*Blackburn 1996* ) Nitrogen rather than phosphorus was considered to be the limiting nutrient (*Bond 1993* ).



139. The approach taken in a study of the effects of outfalls from Glenelg and Port Adelaide WWTP's was to determine the concentration of nitrogen compounds above which significant impacts on seagrass communities was likely to occur. This concentration equates to an "assimilative capacity" for the most sensitive seagrass communities. Recent studies of the Albany harbours in Western Australia had demonstrated assimilative capacities in terms of total nutrient loads. The Albany harbours, compared to Gulf St Vincent are small, relatively enclosed and with restricted interchange with oceanic water. Gulf St Vincent is large and well mixed, and consequently concentrations were considered to be more relevant than total nutrient loads. Boston Bay is an embayment of approximately 70km<sup>2</sup> with an average depth of about 11m (maximum depth of 17m). It is connected hydraulically to two major embayments, Spalding Cove and Proper Bay, and to Spencer Gulf which exchanges freely with the Southern Ocean (*Figure Four*). It was not possible within the scope of the research project, or with available data, to determine which of nutrient concentrations or nutrient loads are of greater significance in Boston Bay (*Bond 1993*).
140. **Nutrient Status of Boston Bay:** Nutrient concentrations in Boston Bay were studied and modelled in relation to commercial tuna farming. Ambient total nitrogen concentrations in the Bay typically ranged from about 0.2-1mg/l (EWS) data). Data from oceanic waters south of Esperance in Western Australia suggested that background levels of total nitrogen are of the order of 0.2mg/l. Standards defined in the "Marine Environment Protection Act 1990" set the limits for total nitrogen as 0.2mg/l for 'Level 1' for pristine marine ecosystems and 0.5mg/l for 'Level II' for modified marine ecosystems (*Bond 1993*).
141. The known sources of nutrients included the E&WS untreated sewage outfall on the south side of Billy Light's Point, fish processing industry on the north coast of Proper Bay, stormwater and septic tank runoff, and various minor point sources around the main docks area and the marina in Porter Bay. It had not been possible to accurately determine the concentrations of nutrients in Boston Bay resulting from these various sources, however it seemed likely that they contribute between 0.3 and 0.8mg/l of total nitrogen to the bay waters (*Bond 1993*).
142. In Gulf St Vincent, *Amphibolis* seagrass communities appeared to be adversely affected by epiphytism when dissolved nitrogen concentrations exceeded about 0.01mg/l, while *Posidonia* communities showed signs of stress from epiphytes at concentrations greater than about 0.1mg/l. Under the guidelines of the Act, and when compared to Gulf St Vincent, Boston Bay was considered to be moderately polluted and its marine ecosystems would rate 'Level II' protection. Any additional nutrient inputs from tuna farming needed to be considered critically in the light of the existing high ambient levels. However the absence of *Amphibolis* in Boston Bay meant that assessments of pollution effects had to be directed to the less sensitive *Posidonia* communities (*Bond 1993*).
143. **Data and Methodologies:** Relevant data include long term measurements of ambient total nitrogen concentrations in and around Boston Bay (EWS), limited tidal current data (SA Department of Primary Industries (Fisheries)) and estimates of feed loads and dissolved nitrogen concentrations from Lincoln Marine Farm 1992 (*Bond 1993*).

144. Predictions of total nitrogen concentrations resulting from tuna farming had been made using the MIT Transient Plume Model (Adams et al. 1975) which had been developed for buoyant plumes discharging into large bodies of water with tidally varying currents. The model predicted far-field concentrations in plumes which were dispersed by vertically and horizontal mixing and advection. The critical parameters for this dispersion were the longshore and onshore/offshore diffusion coefficients. In addition nutrients can be taken up by phytoplankton in the water column, benthic algae and seagrasses, and sedimentary processes. It was assumed, so that predictions were conservative, that this uptake was negligible. The buoyancy of the plume also influences its dispersion, with buoyant plumes entraining surrounding water, producing near field dilutions. Water flowing through a tuna cage will not have its density significantly affected by processes within the cage, and therefore it will exit with a density very close to that of the surrounding water. Sensitivity analysis of different assumed buoyancies demonstrated that the model predictions were not significantly different of buoyancy estimates ranging over about five orders of magnitude (from  $10^{-9}$  to  $10^{-4}$  kg/m<sup>3</sup>) (Bond 1993 ).
145. Horizontal diffusion coefficients were assumed to vary in relation to the standard deviation of the plume width according to a standard 4/3 power law:  $E = A.b^{4/3}$  where E is the horizontal diffusion coefficient in ft<sup>2</sup>/s and b is the plume width in ft. E is approximately 11 ft<sup>2</sup>/s (Bond 1993 ).
146. Critical values for the model (Bond 1993 ) are given below.

Cage Dimensions

Radius of cage (m)	20
Depth of cage (m)	10
Depth of water (m)	15
Cage cross section (m <sup>2</sup> )	400
Cage volume (m <sup>3</sup> )	12566.4
Cage volume (L)	12566370

Lease Dimensions

Radius of lease (m)	70
Cross section (m <sup>2</sup> )	2100
Volume of lease (m <sup>3</sup> )	230907
Volume of lease (L)	2.3E + 08

Current Speeds

Average tidal current speed (m/s)	0.03
Net current speed (m/s)	0.000347

Water Volumes Through Cage

Under influence of tidal or net current conditions

	<u>Tidal Current</u>	<u>Net Current</u>
Volume (m <sup>3</sup> /s)	12	0.14
Volume (m <sup>3</sup> /h)	43200	4.90
Volume (m <sup>3</sup> /12hr)	518400	6000

<u>Feed Loads and N content</u>		<u>Dissolved N Loads as excreted</u>	
Feed load (t/d)	1.125	Dissolved N (t/d)	0.034
Feed load (kg/h)	46.88	Dissolved N (kg/h)	1.41
N in feed load (kg/h)	1.41		

\* *Note* : It is assumed that all nitrogen in the feed is excreted. In reality about 5 per cent of the nitrogen is converted to protein nitrogen, but this can be disregarded.

#### Dissolved N Concentrations

	<u>Tidal Current</u>	<u>Net Current</u>
N conc. in cage (mg/l)	0.000032	0.0028
N conc. at lease boundary (mg/l)	0.000006	0.00054
Initial dilution (cage N:lease N)	5.25	5.25

147. The concentration figures given above were alternatively for conditions where the tidal current is assumed to sweep the nutrients from the cage, and for where just the much lower speed net current removed the nutrients. The estimates for far-field N concentrations used the more conservative net current speeds, since it is the net drift of the plume which removes nutrients from the lease area. The tidally reversing currents tend to return the plume back to the pontoons. *Figure Thirty Two* illustrates the tidal currents measured by current meter at location PL 1 over a period of 24 hours in August 1992. Note that the meters stalled at currents below 1.5cm/s. Therefore actual currents were estimated using a simple sine curve fitted to the real data. The fitted curve is illustrated in *Figure Thirty Two* and the estimated currents rather than real data were used in the transient plume model. The times and heights of high and low water are also shown in *Figure Thirty Two* (Bond 1993 ).
148. Net current vectors were plotted, the axes are aligned north-south and east-west. The net movement was in a SSE direction. For the available data it can be seen that the net drift component over a 12 hour tidal cycle was only about 45m south and 8m west. Although this movement is small, it is still adequate to pass large volumes of water through the cages (see data above). At the time of measurement, wind speed was low. Other data not used in the models indicated that wind advection was significant for wind speed over 20 knots, and south westerly winds of that magnitude can reverse the net drift. Net drift in windy conditions may also be several times larger than during calm weather. A radial frequency plot (current rose) for the current data shows the dominant current directions during a tidal cycle were from the south and SSE (Bond 1993 ).
149. **Far-Field and Near-Field Total Nitrogen Concentrations:** Total nitrogen concentrations, averaged through the water column (15m depth), modelled using the TPM model, were plotted as concentration contours on the model grid in figures 6 (a-d) and 7 (a-d). The models assume a single cage with the dimensions given previously. In reality a farm likely to contain up to ten pontoons. The larger number of pontoons does not invalidate the models. Predicted concentrations for more than one pontoon in a lease can

be scaled linearly from the single cage predictions. If several cages are considered as a point source, then near-field concentrations would be X times those for a single cage, where X is the number of cages. In reality, because nutrient concentrations fall rapidly to very low levels over distance of a few hundred feet, there may be little interaction between the plumes from separate pontoons (*Bond 1993* ).

150. Far-field concentrations, (*Figure Thirty Three* ) ie. those beyond the transition zone and up to 3200m from the source showed rapid fall to extremely low levels. Only the central part of the modelled grid is shown. Beyond this, concentrations are so low that they cannot be predicted with certainty. The concentration units are ug/l. The grid spacing is 250ft, although a 50ft interval was used by the model over the central four grid squares. The individual snapshots of nutrient concentrations are at three hourly interval, starting at the peak of the high tide. The contours are near circular, reflecting the low net drift speeds (*Bond 1993* ).
151. Near-field concentrations (*Figure Thirty Four* ) were modelled and concentration contours plotted. Near-field concentrations were modelled using a 25ft grid spacing at the centre of the model grid and 50ft spacing beyond 250ft. The location of a circular tuna pontoon within a square lease boundary is shown. The concentration units are again ug/l. The shapes of the contours are slightly different to those in *Figure Thirty Three* because of the finer grid spacing and assumptions required for allowing the model to be run within the transition zone or zone of initial dilution. Strictly, the model is not designed to accurately predict near-field concentrations, but the agreement in predictions using the near-field and far-field models indicates that the assumptions used are valid (*Bond 1993* ).
152. **Conclusions:** Transient Plume modelling of tuna farm nutrient suggest that nutrient concentrations resulting from a single farm are very low within a few hundred feet of the farm. It is unlikely that concentrations even within the pontoons themselves would ever greatly increase above background levels. With predicted concentrations at lease boundaries, even under conditions of low tidal current speeds, are likely to be about 0.1 ug/l. On this basis, nutrients are unlikely to be the factor which limits the number of pontoons in the bay. It is more likely that physical constraints such as the area of the bay, suitable localities, and avoidance of shipping areas, would place an upper limit on the number of pontoons (*Bond 1993* ).
153. An assimilative capacity in terms of nutrient loads could not be estimated at the time of the research project (ie finished May 1993). however, in a separate FRDC project (*Petrusevics 1997* ), Petrusevics was able to model the tuna farm carrying capacity of Boston Bay. The predictive capacity of the Petrusevics model will only become clearer over the years with the emergence of a long-term data base from the full environmental monitoring program (see *1997 EPA Report* ).

**Fig. 32** Tidal current data for location PL1 in Boston Bay. Because of the low current speeds much of the data are missing due to the 1.5 cm/s stall speed of the meter. Fitted data were used in nutrient models

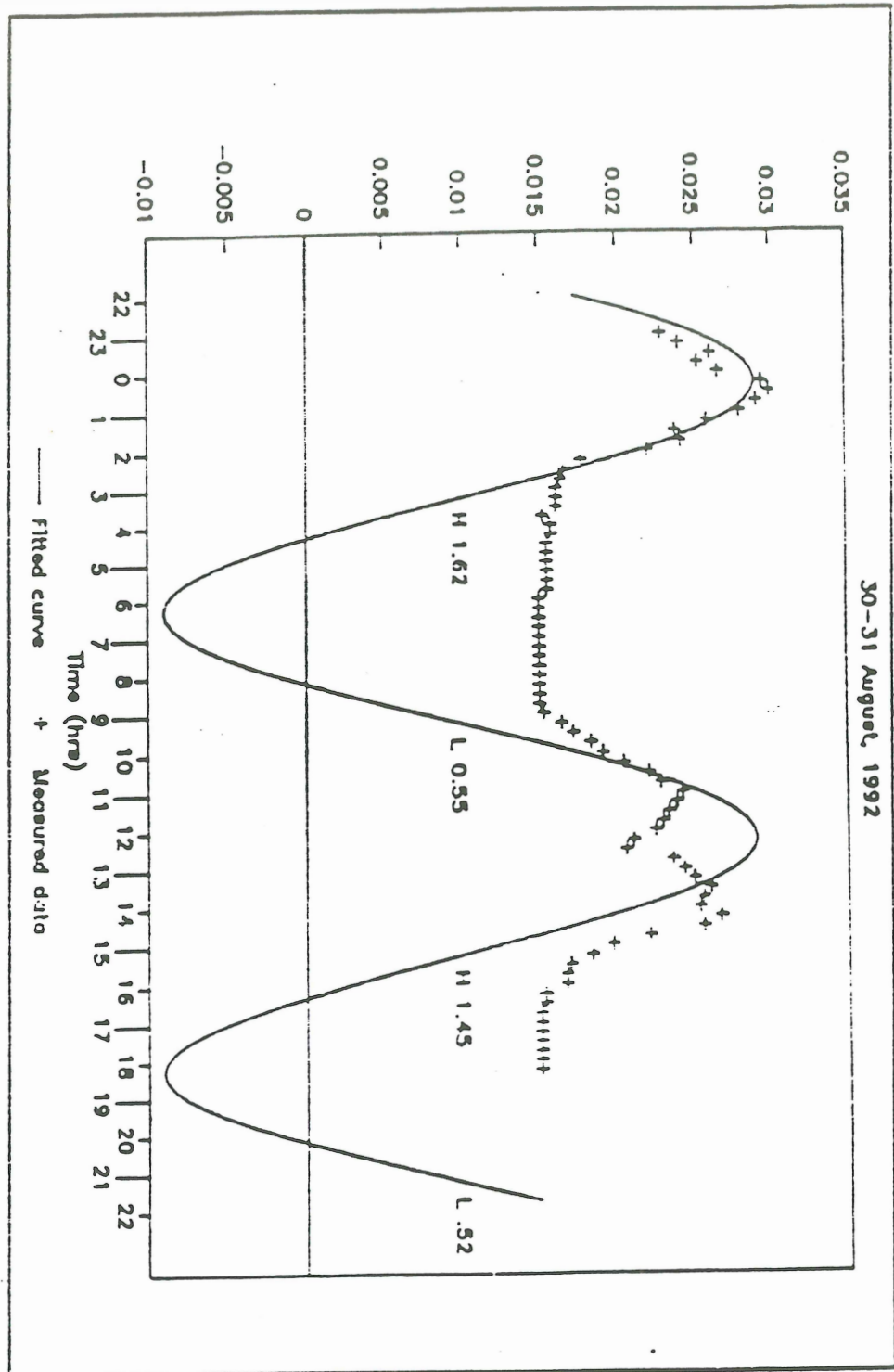

Source: Bond, 1993

**Fig. 33** Far field total nitrogen concentrations at 3 hourly intervals for a single cage located near PL1

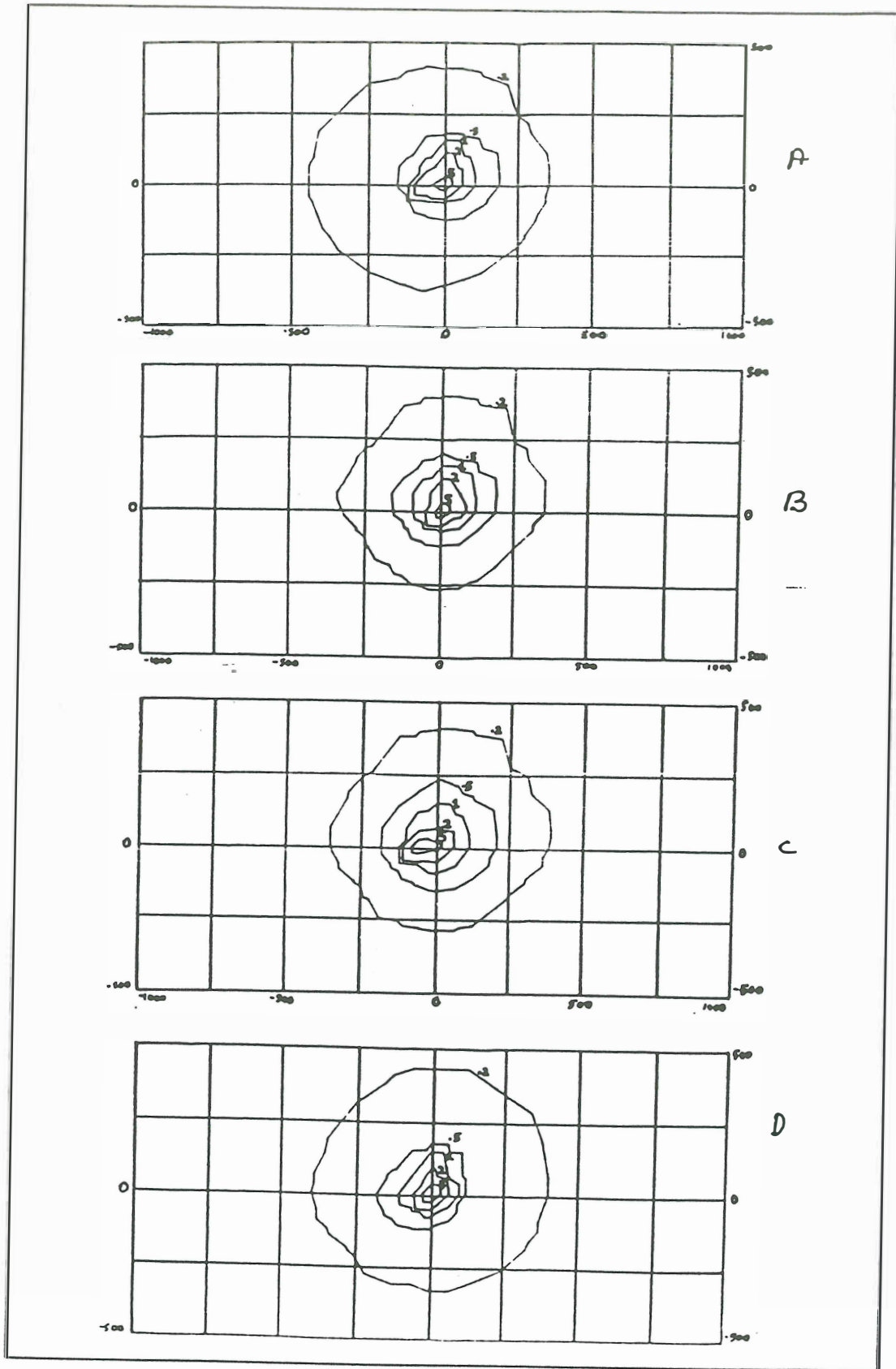
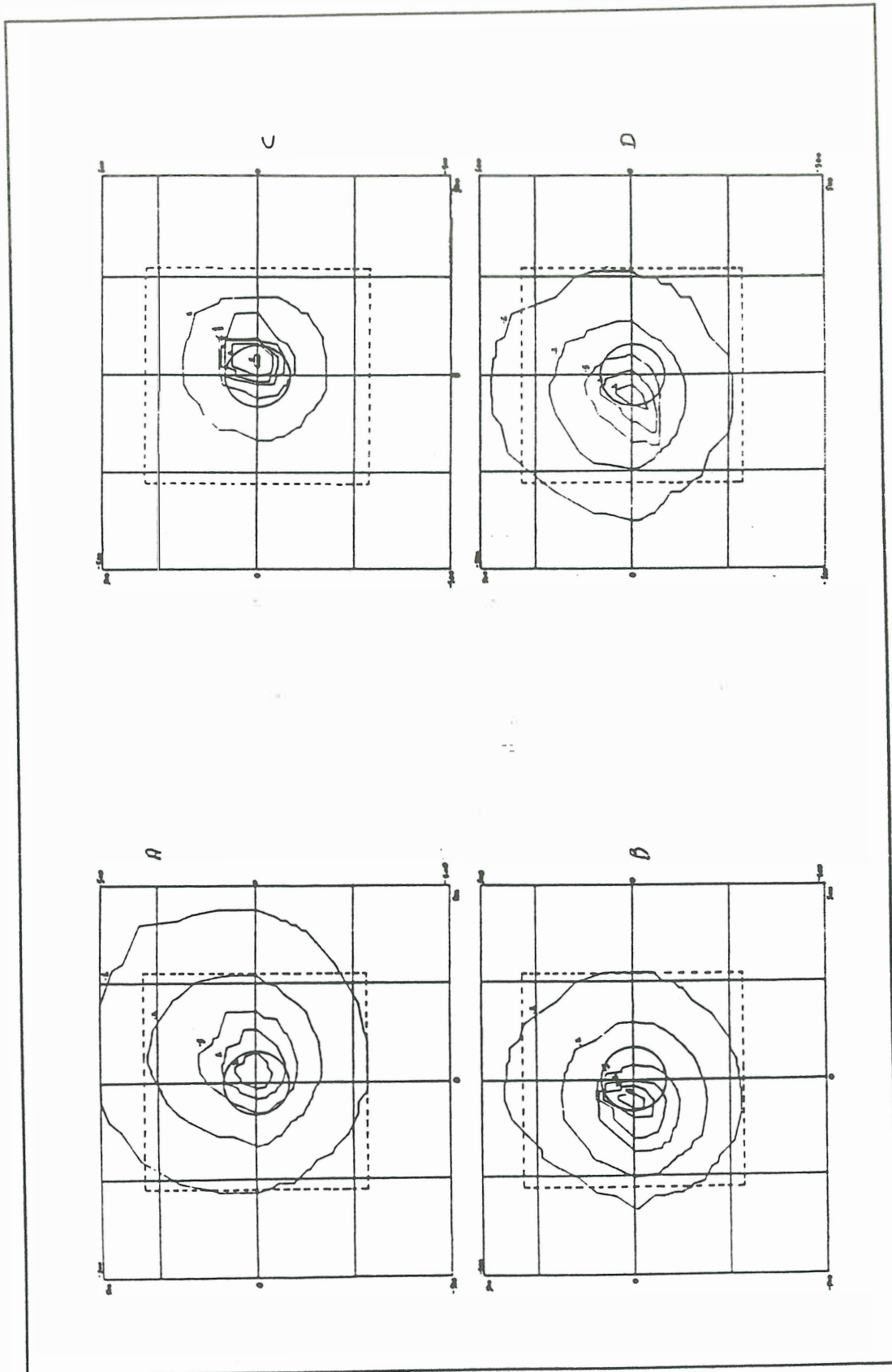

Fig. 34 Near field total nitrogen concentrations at 3 hourly intervals for a single cage located near PL1



## Issues Arising Subsequent to the Project Report

154. This Report largely covers the period of Project 91/56, to May 1993. Since then:

- (1) The industry has developed to an input tonnage of over 3,000 tonnes per annum.
- (2) A substantial research structure has been created, operating under the framework of a Memorandum of Understanding between ATBOA and SARDI. The structure includes research programs on fish health, environmental monitoring, nutrition and, until 1996, on SBT spawning.
- (3) A range of research studies have been completed (see below).
- (4) The industry has sustained its move towards a high value-added industry (see below).

155. Studies completed include:

- (1) Fitzgerald C, Bremner A, *"Improving the stability and nutritional value of frozen small fish for tuna feed"*, IFIQ project for National Seafood Centre, Project Number 6, July 1994.
- (2) Bruce B P, *"A feasibility study of methods to assess and manage waste dispersal and deposition from the southern bluefin tuna (Thunnus maccoyii) farms of Boston Bay, Port Lincoln, South Australia"*, University of Adelaide, SA, March 1997 (Thesis).
- (3) Hawkesford T, *"Immunostaining of a ciliate protozoan causing significant mortality of farmed tuna: the development of a rapid identification technique which will enable improved farm management practices to be implemented to minimise fish mortality"*, FRDC project 95/083, November 1996.
- (4) Crosbie P, *"Environmental factors and chemical agents affecting the growth of uronema nigricans"*, University of Tasmania, November 1996 (Thesis).
- (5) Paxinos R, Clarke S M, Matsumoto G, *"Phytoplankton dynamics of Boston Bay, South Australia"*, SARDI, June 1996.
- (6) Cronin E, *"An investigation into the effects of net fouling on the oxygen budget associated with southern bluefin tuna (Thunnus maccoyii) farming"*, University of Adelaide, SA, November 1995 (Thesis).
- (7) Petrusевичs P, *"Assessment of the carrying capacity of Boston Bay South Australia with a view towards maximising the southern bluefin tuna resource"*, FRDC Project 93/169, 1996.
- (8) Turner D B, Sukacz V, *"Tuna feed production facility, feasibility study"*, Aquasearch (prepared for Tuna Boat Owners Association of Australia), October 1996.



- (9) Cheshire A, Wesphalen G, Kildea T, Smart A, Clarke S, "*Investigating the environmental effects of sea-cage tuna farming*", Parts One and Two, FRDC Project 94/091, 1996.
  - (10) Kinhill Engineers, "*Remote sensing of macrophyte communities in Boston Bay, South Australia*", FRDC Project 93/169, 1995.
  - (11) Nichols J, Cartwright C, Clarke S, "*Environmental Protection Agency (EPA) - Southern Bluefin Tuna (Thunnus maccoyii) Farming*", Environmental Monitoring report April 1996-June 1997, Boston Bay, Port Lincoln, South Australia, July 1997.
  - (12) Smart A R, Clarke S M, Van Barneveld R J, Carter C G, Paterson B D, "*Growth of sea-cages, southern bluefin tuna, Thunnus maccoyii (castelnaui) fed manufactured diets*", July 1997 (to be published).
  - (13) Tuna Boat Owners Association of Australia, "*Code of Conduct for Tuna Farming*", 1995.
156. In addition, there are numerous other unpublished papers by scientists working under the tuna nutrition program of the CRC for Aquaculture and the MOU between SARDI and ATBOA.
157. The research structure is targeted at:
- (1) Building a long-term data base, and crisis response capacity, for fish health and environmental monitoring.
  - (2) Improving utilisation of wet feeds.
  - (3) Developing a useable pellet and then improving it over the long-term.
  - (4) Researching ways of improving flesh quality, including colour.
  - (5) Research ways to add further value eg loining.
158. Most of the above targets are contained in the FRDC Tuna Farm Research Sub-Program, starting in July 1997.

## REFERENCES

- Bond, T**, "Port Lincoln aquaculture management plan", Department of Environment and Land Management and Department of primary industries, 1993.
- Caton A, Mckoughlin K, Williams M J**, "Southern Bluefin Tuna: Scientific Background to the Debate", BRR Bulletin No. 3, 1990.
- Caton A (ed)**, "Review of Aspects of Southern Bluefin Tuna, Biology, Population and Fisheries", BRR, 1990.
- Cronin E**, "An investigation into the effects of net fouling on the oxygen budget associated with southern bluefin tuna (*Thunnus maccoyii*) farming", university of Adelaide, SA, November 1995 (Thesis).
- CSIRO (Anon.)**, "Report of the Second Meeting of the CCSBT Scientific Committee", Unpublished, September, 1996.
- Econosearch**, "The Economic Impact of Aquaculture and Fishing Industry Activity on the Eyre Peninsula Region of South Australia", Prepared for Primary Industries SA, January 1997.
- Green G, Nayar M**, "Individual Transferable Quotas and the Southern Bluefin Tuna Fishery, Economic Impact", ABARE Occasional Paper No. 105, 1989.
- Hallegraeff G M**, "Aquaculturists' Guide to Harmful Australian Microalgae", Hobart 1995.
- Kingston A, Brown D**, "Foreign involvement in the Australian fishing industry", ABARE Research Report 93.6, 1993
- Koga Y**, "Personal Communication, February 1995 (in Japanese).
- Krueger K**, "SBT farming - will it work", Australian Fisheries, July 1991.
- Nicoll, R** "World-first attempt to spawn SBT in captivity", Australian Fisheries, November, 1991.
- Nichols J, Cartwright C, Clarke S**, "Environmental Protection Agency (EPA) - Southern Bluefin Tuna (*Thunnus maccoyii*) Farming" Environmental Monitoring report April 1996-June 1997. Boston Bay, Port Lincoln, South Australia, Unpublished, July 1991.
- Noye B J, Grzechnik M G, Stevens J M**, "Modelling effect of a strong autumn wind on tidal currents in Boston Bay, South Australia", to be published 1997.
- Petrusevics P**, "Assessment of the carrying capacity of Boston Bay with a view towards maximising the southern bluefin tuna resource", FRDC Project 93/169, 1996.
- Rough K**, "Fish Health, Progress Report", Unpublished 1994.
- Tuna Boat Owners Association of Australia**, "Road to a High Value Added Tuna Industry", unpublished, 1990.

SUMMARY OF ACTIVITIES AND OBSERVATION OF  
SBT EXPERIMENT ABOARD DANGEROUS REEF OBSERVATORY  
EARLY 1990

**Operation**

Thirty-five fish were brought in by the "Empris lady". The fish varied between 9-14kgs, caught on the Cabbage Patch, a lump area south-west of Port Lincoln and about 60km from the Dangerous Reef platform.

The 5 hour carrying trip was generally in calm seas. Around 9 fish were carried each trip, normally in the smallest tank on the vessel.

**Losses**

Within days of their relocation, 7 SBT had died. The most probable cause of death would have to be the physical injuries sustained through capture and transportation to the platform and the associated handling involved. All fish had a large percentage of their bodies badly damaged. Some had deep lacerations while others had severe eye damage. In some instances, the pectoral fin appeared broken at the joint. The whole transfer operation would have obviously been very stressful.

Of the remaining fish, it became evident that in the initial stages, there were other signs of physical deterioration and stress in the form of fraying of the pectoral and tail fins, a general dulling of topside body colour, erratic swimming patterns and the appearance of a white fluffy "fungus" to damaged areas.

Shortly after a feeding routine was established and possibly an acclimatisation to the new environment, SBT soon appeared "relaxed" - in feeding and around a single diver, and began rolling and chasing each other. Most importantly and very encouraging was the recovery of damaged tissue, ie regrowth of fin membrane and a disappearance of the white fluffy fungus which exposed healed scars and minor lacerations.

The majority of losses after the initial damaged fish, has been caused by a condition (inflicted - contracted?) to the eyes of SBT, labelled "Milky Eye" by the crew. The condition usually began in one eye and more often than not spread to the other. In some cases, it manifested itself in both eyes simultaneously. The actual eye itself became marbled or opaque with no obvious signs of physical damage to the surrounding eye socket. In some cases, the eye tissue appeared to have been eaten into.

One whole fish and the head of another, both having died from the condition were taken to Bluefin Exporters Pty Ltd for further examination. As the eyes deteriorated, the fish appeared to lose equilibrium while swimming. Whether this was due to general disorientation through blindness or an attack by the offending organism to the balance mechanism of SBT is not known.

This condition deserves serious investigation. It may very well be peculiar to the location or construction of the platform, or in fact some dietary deficiency.

*Note:* Subsequent experience was that the "Milky Eye" fungus was a result of bad hooking practices, and this was actually corrected quickly during the formal experiment starting in 1991.

### **Feeding**

It took SBT approx 10 days to adjust to the feeding method which consisted of broad casting partially frozen blue pilchards into the pool area of the observatory. They had to compete with very aggressive Australian Salmon well versed with the feeding procedure. Whether this assisted or hindered SBT accepting the feeding routine is not clear. However, once awake to the routine, SBT quickly asserted themselves at the head of the pecking order, generally beating the salmon to the pilchards in the initial frenzy. With the procedure firmly established, the fish, including the salmon required approx 12kg/day. With 2 trips per day, less interest in feeding was shown during the morning trip. SBT and salmon were far more likely to "perform" at the afternoon feeding. While regular trips were under-taken, 12-15kg per day appeared to satisfy all fish. With the onset of foul weather and less trips per week, fish required between 20-30kg per feed. In one instance, after a 6 day break, 4x10kg bags were required before all the fish appeared no long hungry.

SBT were initially interested in pilchards alone. Since then, their diet has included red mullet, hake fillets, squid, tuna pieces, salmon fillets, snook, leather jackets, nannygai and tommies, frozen and live. While the platform is generally full of live tommies, SBT show no interest in them. However, if live tommies are thrown into the pool in normal feeding manner, they are quickly pursued, and devoured. SBT appear interested in surface food only.

Also worth mentioning is the fact that on some days, SBT and salmon show no interest in feeding. These days are not frequent. One fell on a full moon, yet full moons since have not produced the same phenomenon so there appears no real pattern. They appear very flighty on these days as if "spooked" - a definite possibility considering location of the platform.

Despite feedings becoming irregular due to adverse weather, SBT definitely appear to have gained condition. They appear fuller in the tail. Estimating actual increases in weight and length would be difficult but in general increase in size is evident.

\* \* \* \* \*

**OVERVIEW: FINDINGS OF THE 1st**  
**FEASIBILITY STUDY OF SBT CULTURING**

**(14-31 January 1990)**

OFCF Study Team: Dr Akira Suda  
Teruo Takahashi  
Fumitoshi Suzuka  
Yuichiro Harada  
Tsugihiko Kobayashi  
Shimba Fukuda  
Keiko Mihara

29th January 1990

1. The team believes that our thought concerning the Southern Bluefin Tuna aquaculture has been understood very well by South Australia State Government and Western Australia State Government as well as the Federal Government of Australia. The team, therefore, has gotten the impression that the respective government will consider the matter cooperatively when the permits and/or approvals need to be obtained in implementing the aquaculture technology development project.
2. The team has found the fishermen not only in Port Lincoln, the major centre for tuna fishery, but also in Albany and Esperance are all highly experienced and the positive and cooperative response shown by these fishermen was encouraging.
3. The objectives of this feasibility study are;
  - (1) To collect information and data necessary to organise a pilot experiment geared to developing short-term tuna aquaculture technology during the summer months at the initial stage.
  - (2) To gather information required to conduct a longer-term aquaculture experiment in future, and
  - (3) To have preliminary discussions concerning the memorandum of agreement to be concluded in future.
4. Selection of the findings of the feasibility study is as follows:
  - (1) Selection of locations suitable for staging farming facilities; this is the most critical requirement for conducting successful experiments:

The Departments of Fisheries in South Australia and Western Australia respectively recommended locations possibly meeting the requirements;

- (i) The northern coast of the kangaroo Island and the south-eastern area of Port Lincoln, Boston Bay (only for a short-term experiment) and a few other locations for South Australia, and
- (ii) Albany, the Archipelago of the Recherche in Esperance, Bremer Bay and a few other locations. The team went to some of these places for on-site investigation and also collected advice and opinions of the local fishermen based on their experiences for the other areas which it could not visit.

As a result, the team has come to the following judgement;

- (i) In view of physical and natural conditions prevailing in the northern part of the Kangaroo island, south-eastern part of Port Lincoln and Bremer Bay, it is considered rather difficult to stage the facilities and manage them in these waters. In the interest of finding more locations to install facilities some time in the future, however, it is necessary to continue to gather information on these and other locations which may possibly meet the requirements.
- (ii) Boston Bay is rather shallow, but it seems possible to stage a large culturing facility there. Besides it is known that SBT came in and stayed for over a month there. The team, therefore, considers it is possible to conduct at least a short-term experiment in Boston Bay.
- (iii) One concern with respect to King George Sound in Albany is possible effect of fresh water inflow at the time of heavy rainfall, however, the team still believes it is possible to run a long-term aquaculture experiment with large facilities there.
- (iv) The team needs to wait for a report to be made in Tokyo by some members of the team who conducted additional investigations in Esperance. It believes, however, that given the information so far collected, it is possible to work in Esperance. The problem is rather long distance from the fishing grounds to the staging area. It would be possible to conduct an experiment, if for a short period, within the bay.

In conclusion, the team wants to look at Boston Bay and King George Sound as its first choice for the site in implementing the pilot experiment and keep Esperance as an alternative site.

(2) Infrastructures:

The team investigated the possibility of obtaining cooperation from local fishermen, availability of young fish, availability of feed and availability of materials for locally building gear.

- 1) Cooperation of fishermen: Obtainable.
- 2) Availability of young fish:

- Boston Bay: Available, but fish is of a medium size. It takes several hours to one day to get to the staging area from the fishing grounds.
- King George Sound: Available. Small-size fish is obtainable in the waters very close to the staging area. It also seems possible to work on the development of a new young fish transportation infrastructure.
- Esperance: Available. The size of fish is in between what is available in Boston Bay and King George Sound.

In terms of the size of fish available, fish caught in King George Sound is the smallest and should be easiest to work with. If, however, the project succeeds in culturing medium size fish now commercially harvested by the Port Lincoln fleet (2-3 year old tuna), much greater economic benefit may be expected.

- 3) Availability of feed:  
Pilchards which will be used for feed at least at the initial stage are available in all of the three sites.
  - 4) Availability of materials for building gear:  
Available in all the three sites.
- (3) Collection of biological data from the view point of aquaculture:
- 1) Information was gathered through the discussion with local fishermen at the above three locations with respect to "capturing fish" (how to bring in fish on the vessel - how to handle fish - appropriate fish holding tanks to keep fish alive - how to transfer fish into sea cages), in particular, capturing of fish of a medium size. The team has not yet identified the capturing method which assures success.
  - 2) It is, therefore, difficult to organise a pilot experiment with the information and knowledge obtained to date.
  - 3) In order to develop a specific plan for the pilot experiment, it is necessary to understand the process of how fish caught dies onboard the vessel and to collect information in advance regarding the type of vessel and fishing gear which assures successful capturing of young fish.
  - 4) It would be appropriate to have further communication with the local research laboratories to learn about possible cooperation from these institutions before the planned experiments commence.

- 5) The team was unable to collect information about these aspects in this feasibility study. It is, therefore, necessary to conduct the second feasibility study for this purpose.

5. Approach for the second feasibility study:

- (1) In light of availability of young fish, existence of readily useable facilities, ease of working closely with local fishermen and Tuna Boat Owners Association of Australia, and cooperation obtainable from the government agencies and other institutions concerned.
- (i) Port Lincoln would be the best site for conducting the study, but  
(ii) Albany also meets the basic requirements.
- (2) The term, therefore, wish to choose Port Lincoln as a primary site or the second feasibility study, but will examine whether additional study should be made in Albany as well after it goes to Japan.
- (3) The specific plan for the visit will be worked out after the team goes back to Japan as soon as possible. It will most likely be March to April.
- (4) OFCF will proceed with the study in close consultation with the Federation of Japan Tuna Fisheries Cooperative Associations and the Tuna Boat Owners Association of Australia. Once the itinerary of the second visit is decided, OFCF will contact the organisations concerned and hope that they extend support to make the visit a success.

6. Thought on the pilot experiment.

At any rate, the team wants to re-examine all these aspects with reference to the preparation for the memorandum of Agreement after it completes the second feasibility study.

In view of the commitment of OFCF as a semi-governmental organisation, it will work on the project in consultation with the Federal Government of Australia and the state governments. As OFCF is in the position to assist the building of a new industry in Australia, it hopes that the Australian side will also extend positive support in its effort and, if possible, share part of the work in an agreeable division of labor arrangement.

Akira Suda



## SUMMARY REPORT OF THE 2ND FEASIBILITY STUDY

### OFCF STUDY TEAM

31st March 1990

- 1/ Period: 18th March - 2nd April 1990.
- 2/ Place: Port Lincoln, South Australia.
- 3/ Team Member: Mr Takahiko Hamano, Expert of Tuna Culturing  
Mr Yuichiro Harada, Coordinator  
Mr Tsugihiko Kobayashi, Expert of Culturing Gear  
Mr Shimba Fukuda, Coordinator
- 4/ Schedule: See attached "Working Schedule".
- 5/ Result:
  - (1) Catching
    - (a) Sampling was carried out three times using chartered vessel "Empris Lady".
    - (b) The local method, pole and line, was used to catch Southern Bluefin Tuna.
    - (c) Number of samples caught was 77 in total.
    - (d) Fish size and weight in average were approximately 88cm in full length and 13.5kg.
  - (2) Handling and Quieting
    - (a) Fish was handled and calmed down with extra care to minimise damage using following material on board.  
Large vinyl tank (3.0m x 1.0m x 0.7m).  
Small vinyl tank (1.3m x 0.7m x 0.35m).  
Vinyl stretcher.  
Vinyl sheet.
    - (b) Fish were numbered having a rubber band on the tail.
  - (3) Transporting

- (a) Four brine tanks on the Empris lady were used for transportation of fish, which were two tanks of 9.6 tonne capacity and tow tanks of 17.8 tonne.
- (b) Number of Southern Bluefin Tuna put into tank was 75 in total.
- (c) 25 Southern Bluefin Tuna died during transportation in total.

Time required for transportation was about 9.5-13.5 hours.

(4) Putting into cage

- (a) Following method was done to transfer fish from tanks to cage.
  - \* 1st, water in the tank pumped out until the depth became about one metre.
  - \* 2nd, one or two person went into tank to pick fish up individually using stretcher and put it into vinyl bucket.
  - \* 3rd, fish was transferred in the bucket with water to the cage.
- (b) Number of Southern Bluefin Tuna put into cage was 48 in total.

(5) Caging (feeding)

- (a) The size of the cage at Dangerous Reef was about 30m x 10m x 2.5m.
- (b) Southern Bluefin Tuna was fed with pilchards once a day.
- (c) Number of Southern Bluefin Tuna dead during 8 days caging was 11.

(6) Summary findings

(1) Catching

- (a) The local method, pole and line, is appropriate to catch Southern Bluefin Tuna.
- (b) The fish which is in the following condition is not appropriate for caging. We estimated about 30% of catch was inappropriate.
  - \* Bleeding.
  - \* Not be able to calm down.
  - \* Damaged upper jaw by hooking.

(2) Handling and Quieting

- (a) Small vinyl tank and stretcher are most appropriate materials for handling and quieting Southern Bluefin Tuna easy and effective in this study.

- (b) Fish should be handled and calmed down in the tank with the water.
  - (c) Fish should be calmed down again at the point of putting into tank.
  - (d) It is necessary to take enough intervals (2-3 minutes) for each fish putting into tank.
  - (e) On the 1st trip, we got low survival rate (40%) during transportation because:
    - \* We didn't select appropriate fish carefully.
    - \* We put each Southern Bluefin Tuna into tank within short time.
    - \* There were a lot of attachments, shells etc. inside the tank, therefore, Southern Bluefin Tuna was injured.
  - (f) On the 2nd trip we got high survival rate (97%) during transportation because we solved the above problems.
- (3) Transportation
- (a) On the 2nd trip, one tank (17.8 tonne) had 10 Southern Bluefin Tuna. (MBW  $13\text{kg} \times 10/17.8 \text{ tonne} = 7.3\text{kg/tonne}$ ). In this condition 100% of the fish survived the 9.5 hours of transportation.
  - (b) Light into tank seems to be necessary for night transportation according to the Japanese experience.
- (4) Putting into Cage
- We didn't find out any problems on the method which we used for putting Southern Bluefin Tuna into the cage in this study.
- (5) Caging/Feeding
- Southern Bluefin Tuna started feeding 3-5 days after they were put in the cage.

## WORKING SCHEDULE

MARCH 19th (Mon.)	Arrived at Port Lincoln.
" 20th (Tue.)	Meeting with people concerned at Bluefin Exporters. preparation of Equipment.
" 21st (Wed.)	1st Trip.
" 22nd (Thurs.)	1st Trip.
" 23rd (Fri.)	Observation trip to cage/platform in Dangerous Reef.
" 24th (Sat.)	2nd Trip.
" 25th (Sun.)	Observation trip to cage/platform in Dangerous Reef.
" 26th (Mon.)	3rd Trip.
" 27th (Tues.)	Observation trip to cage/Platform.
" 28th (Wed.)	-Ditto-
" 29th (Thurs.)	-Ditto-
" 30th (Fri.)	-Ditto-
" 31st (Sat.)	Final review meeting with people concerned at Bluefin Exporters.
APRIL 1st (Sun.)	
" 2nd (Mon.)	Leave Port Lincoln

CONDITIONS OF APPROVAL FOR DEVELOPMENT APPLICATION NO. 931/5010/90

1. The development hereby approved is for 6.25 ha. site, located in 15-16 metres of water, approximately 1.4 kilometres off-shore, directly east from Section 17 and 18 in the Hundred of Lincoln, within the area bounded by the following Australian Mapping Grid References:  
  
North West corner: 579600 east, 6161150 north;  
  
North East corner: 579850 east, 6161150 north;  
  
South East corner: 579850 east, 6160900 north;  
  
South West corner: 579600 east, 6160900 north.  
  
(See Location Maps)
2. This will be a temporary approval for three (3) years.
3. The development hereby approved shall be carried out in accordance with information submitted with the application, unless varied by the following conditions.
4. The use of any anti-predator netting shall require the approval of all of the relevant Government agencies.
5. All structures, equipment, buoys, and flotations (except for that required by the Department of Marine and Harbours) are to be of a black, dark grey, dark blue, dark brown, or dark green colour, and only one such colour is to be used for such materials.
6. The lease area shall be marked at all times in accordance with the Department of Marine and Harbours Navigational and Safety requirements (present standards in force attached).
7. All structures are to be adequately secured and sufficiently weighted to ensure they do not drift outside the lease area.
8. There is to be no use of the chemical tributyltin (T.B.T.).
9. A programme of monitoring as hereinafter prescribed in Appendix 1 shall be carried out as a minimum program with all results being forwarded to the Department of Fisheries, which subsequently will forward this information to the Department of Environment and Planning and the Department of Lands.
10. Prior to the use of any type of chemical or drug the Department of Fisheries is to be advised, in writing or verbally, of the type and quantity and any known impacts that may occur to the environment as a result. A written submission containing the above information is to be forwarded within 14 days.
11. The applicant or other person making use of the subject area now approved, shall at all times, maintain in good, tidy condition, to the satisfaction of the Committee, in all respects, the subject area and any debris associated with the development washed up on-shore shall be removed.
12. When the area is no longer used for aquaculture, the site shall be returned to a condition which complies with the policy for Aquaculture Site Rehabilitation, with all structures being removed, cost of such reinstatement and removal being borne by the applicant.

- NOTES:
1. This approval is for two (2) cages and planning approval is necessary if further cages are proposed.
  2. Approval is also required for any on-shore facilities. In this regard your attention is drawn to the fact that there is to be a no storage of equipment or cleaning of nets on any public foreshore, without appropriate approvals being given.
  3. Attention is also drawn to the fact that it is the vendor's responsibility to ensure that fish sold complies with the requirements of the Food Act, 1985.
  4. At no stage will permission be given for the slaughter of any predators to the operation.
  5. If sharks are found to be attracted to the proposed venture and a problem to other users of the waterways, the licence may be revoked.
  6. You are advised that the maximum stocking level and the requirement for monitoring will be contained in the authority issued by the Department of Fisheries.
    - (i) The operator may make an application to amend the maximum stocking level directly with the Department of Fisheries.
    - (ii) If the monitoring highlights significant degradation of the marine environment, the authority will be amended (will/may include a reduction of the maximum stocking level) or revoked.
    - (iii) Costs or part costs may have to be met by the licence holder.
  7. If the proposal is to expand or become permanent in status (i.e. longer than the proposed three (3) years), then a new application will be required.
  8. If an alternative site is required during the proposed three (3) years, then a new application will be required.

## ENVIRONMENTAL MONITORING

### 1. INTRODUCTION

No specific requirements exist at present for the monitoring of aquaculture ventures in South Australia, although all fish farming licence conditions refer to the farmer's responsibility to participate in such studies when they are initiated (possibly on a cost recovery basis). A draft "Oyster Monitoring Program" has been jointly formulated by South Australian Government Departments to address areas of concern raised by those departments and the public, and this is enclosed as an example of an environmental assessment program. Funding for this program is presently being finalised.

At this time no finfish farming occurs in the sea and no specific environmental monitoring program has been established to address the issues arising from such activities. Considerable scientific literature has, however, been collected from overseas on this topic and it is clear that careful monitoring is required because of the potential to detrimentally affect the environment.

### 2. ENVIRONMENTAL MONITORING PROGRAM

The farming of fish in sea pens has been shown to influence the water column and the sea floor, the latter primarily beneath the pens but sometimes over an area extending to about 50 m radius from the pens. The extent and intensity of the effects are based on the water movement typical of the site, the stocking density of the fish within the pens, and the amount and type of feed used.

In regard to this program, all sampling should be done during one neap tide (dodge tide if it occurs) in each of the following months: February, May, August and November. The date and time when sampling or recording is undertaken should be documented.

#### 2.1. Seafloor monitoring

It is recommended that for each site, two transects are established so that they bisect the sea pen area, and are perpendicular to each other. Five permanent sampling stations are recommended along each of two perpendicular radii originating from the point of intersection of the two transects. The position of each station should be permanently marked using a steel post (star dropper) driven into the sediment. It is recommended that the stations be set at distances of 0m, 10m, 20m, 40m and 80m from the centre point along each radii. Additional stations may need to be added if required.

##### Benthic community change

At each station 3 randomly located photographs should be taken of the seafloor and associated flora and fauna. An area of about 50 x 50 cm should be included in each photograph (a PVC pipe frame, with Nikonos camera, flashlight and 15mm wide angle lens has proved most successful in the past). Samples may need to be taken from adjacent areas for taxonomic identification; they should be appropriately preserved and lodged with the museum or herbarium for future reference.

##### Sediment accumulation

Measurements of the height of sediment accumulation should be taken by measuring from the seafloor to the top of 3 fixed pegs at each station. A method should be used that avoids the small erosion or accretion zone around each peg.

### Organic carbon content

Core samples can be taken using a short length of polycarbonate tubing of about 5 cm diameter. The carbon content of standardised subsamples, distinguished by depth from the sediment surface, should then be determined by drying the sample (at about 105 C), weighing it, and then placing it in a muffle furnace (600 C for 2 hours), ashing it and calculating the weight difference. Depending on the size of the sediment particles it may prove necessary to sieve the sediment samples before undertaking this process.

### Eh

An Eh meter in an underwater housing can be used to assess the redox potential at 3 points at each station as well as at different sediment depths. Alternatively, a special coring tube with approximately spaced holes should be used to assess the redox potential of sediments when the core has been raised to the surface. The anaerobic - aerobic interface is most simply determined by pushing small iron pegs into the sediment and on removing them at the next sampling time, measuring the upper limit of the black corrosion band below the sediment surface.

## 2.2 Water Column Measurements

### Water movement

Water movement should be determined at one station at the site for at least a one month period (see application form) so as to cover a number of tidal and lunar cycles. Many types of equipment exist to record tidal currents and/or orbital wave induced water movement; the former is probably of most importance at this site. It is recommended that the water motion be determined at a depth of 5m below the surface.

### Salinity and water temperature

Salinity and water temperature data should be obtained on neap tides (dodge tides if they occur) at a single station at a depth of 5m below the surface.

### Dissolved oxygen concentration

Dissolved oxygen concentration should be obtained on the same spatial and temporal schedule as the seafloor measurements (i.e. every three months at each station) at a depth of 5m below the surface. Small temporary floats attached to the stakes marking the stations on the seafloor can be used to ascertain the sampling points 5m below the surface.

### Water chemistry

Ammonia, oxidised nitrogen (nitrite and nitrate), nitrite and total Kjeldahl nitrogen; soluble and total phosphorus and suspended solids dissolved organic and total organic carbon should be determined from appropriately collected and prepared water samples at the same sampling stations as for dissolved oxygen concentration. The analysis should be undertaken by the State Water Laboratory, Bolivar (Engineering and Water Supply Department).

### Plankton

Chlorophyll a should also be determined for each water sample collected. Separate water samples should also be collected for species identification and abundance estimates.



Others

If antibiotic or other chemical treatment of the fish is undertaken on a frequent basis, sediment and water column sampling for these compounds may become necessary. Microbiological sampling may be necessary if significant disease outbreaks arise or flesh quality is unsatisfactory. Toxic dinoflagellate identification and counts may be necessary if algal blooms occur.

Correspondence form Netcraft Pty Ltd  
18 January 1993

1. The tests were carried out in the Australian Maritime College flume tank at Beauty Point. The persons involved in the design were Ian Cartwright (marine engineer AMC), Graeme Ellis (structural engineer Bridgestone Australia).
2. From the notes "A" and final test results "B" a deduction may be made as to the safe bridle construction.

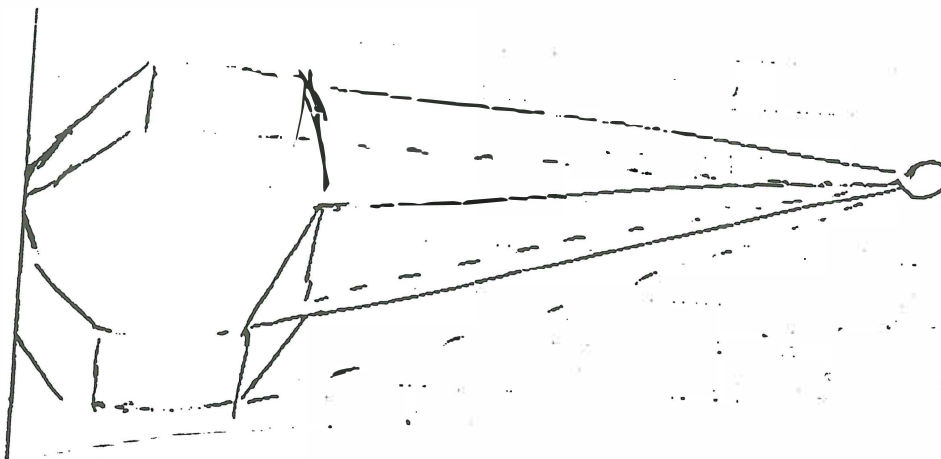

3. Upper level bridles are constructed as follows - centre 22 mm steel galvanised combination wire; outer 18 mm steel; thimbles aluminium to about 200 tonnes. Hammer locks into a lifting eye which is the tow point.
4. The towing bridle is attached to the net by shackles into galvanised thimbles and to the flotation collar by shackles to the appropriate factory manufactured tow points.
5. The top bridles have been floated with K8 floats providing positive buoyancy. This will eliminate the possibility of problems should the towing vessel lose headway.
6. A minimum of 40 mm hard lay polypropylene extension rope should be used as this has an approximate elasticity of 8 per cent. Therefore, the greater the tow length, the greater the safety. The bollard and pivot point should be forward of the rudder point to give better manoeuvring ability.

## Pontoons - Towing Forces

7. The proposed size of cages is generally a hexagon of 16 m side length, as in the sketch, consisting of 315 mm OD polyethylene and 10 m depth.

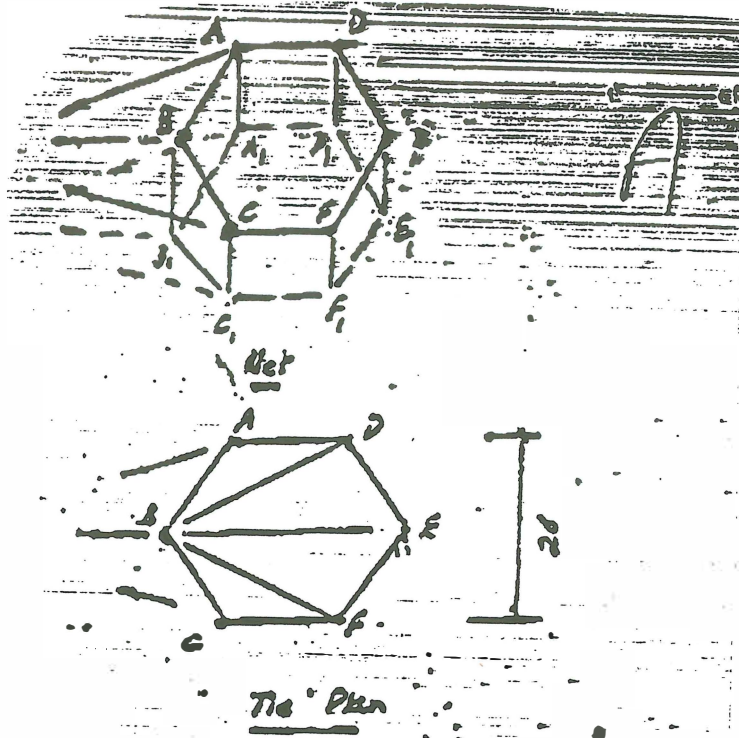

8. The net will be towed by lines attached at A, B and C at surface level, and also at lines A<sub>1</sub>B<sub>1</sub> and C<sub>1</sub> at the level of the base of the cage.
9. Ties are to be provided BD, BE and BF at the surface and B<sub>1</sub>, D<sub>1</sub> and B<sub>1</sub> E<sub>1</sub> and B<sub>1</sub>F<sub>1</sub> at the base of the net.
10. The towage speed through the water is not to exceed two knots (ie one metre/second). Thus, if a one knot current is running against the tow, the effective towing speed must be reduced to one knot. Forces in the tow-ropes and ties are proportional to the square of the speed of water through the net. Thus, a towage speed of four knots would result in four times the forces for which the system is to be designed.

## Drag Coefficient

11. Tests by Milne, AARSNES and Newton show that the drag coefficient depends on the Solidarity Ratio (Sn) of the net, defined as " $\frac{2d}{a}$ " where:

a = mesh size

d = diameter of mesh material.

For this net  $Sn = \frac{2 \times 0.35}{1.5} = 0.093$ .

The above tests give a drag per m<sup>2</sup> of net (D) varying from 0.095 to 0.125. It is proposed to adopt D = 0.120.

### Reduction in Velocity

12. After passing through the lead net the water velocity is reduced by an amount of D/2 and consequently the velocity through the trailing net will be 94 per cent of the towing specifications, ie design is for one metre/second for leading net and 0.94 metre/second for trailing net.

### Forces

13. The supporting pipe is a body of circular cross section and for this the force is  $\frac{C_d \rho V^2 A}{2}$  where:

$$C_d = 1.3$$

$$\rho = 1025 \text{ kg/m}^3$$

$$\begin{aligned} \text{For ABC Force} &= 5.4 \text{ KN} \\ \text{For DEF Force} &= 5.4 \times 0.94^2 = 4.8 \text{ KN} \end{aligned}$$

The forces on the net are:

$$\frac{1}{2} \rho A D V^2 \text{ where: } \begin{aligned} D &= 0.120 \\ A &= 28 \times 10 = 280 \text{ m}^2 \\ \rho &= 1025 \text{ Kg/m}^3 \end{aligned}$$

$$= 17.2 v^2$$

$$\begin{aligned} \text{For ABCA}_1\text{B}_1\text{C}_1 \text{ force} &= 17.2 \text{ KM} \\ \text{For DEFD}_1\text{E}_1\text{F}_1 \text{ force} &= 17.2 \times 0.94^2 = 15.4 \text{ KN} \end{aligned}$$

$$\begin{aligned} \text{Total Towing Load} &= \frac{42.6 \text{ KN}}{10} \\ &= 4.2 \text{ tonnes} \end{aligned}$$

### Distribution of Loads

14. These are:

$$\begin{aligned} \text{ABC takes pipe load } 1/2 \text{ net load } 5.4 + 8.6 &= 14 \text{ KN} \\ \text{A}_1\text{B}_1\text{C}_1 \text{ takes pipe load } 1/2 \text{ net load} &= 8.6 \text{ KN} \\ \text{DEF takes pipe load } 1/2 \text{ net load } 4.8 + 7.6 &= 12.4 \text{ KN} \\ \text{D}_1\text{E}_1\text{F}_1 \text{ takes pipe load } 1/2 \text{ net load} &= 7.6 \text{ KN} \end{aligned}$$

15. Assume that for ABC, half load is taken at B and 1/4 load each at A and C. Similarly for A<sub>1</sub>B<sub>1</sub>C<sub>1</sub> at B<sub>1</sub>, A<sub>1</sub> and C<sub>1</sub>, for DEF at E, D and F, and for D<sub>1</sub>E<sub>1</sub>F<sub>1</sub> at E<sub>1</sub>D<sub>1</sub> and F<sub>1</sub>.

**Loads on Ties**

16. This is:

BE - $1/2 \times 12.4$	6.2 KN (0.62 tonnes)
BF - $3.1 \times \frac{16.5}{16.0}$	3.2 KN (0.32 tonnes)
B1E1 $1/2 \times 7.6$	3.8 KN (0.38 tonnes)
B <sub>1</sub> F <sub>1</sub> $1.9 \times \frac{16.5}{16.0}$	2.0 KN (0.20 tonnes)
Total	<u>20.4 KN (2 tonnes)</u>

**Loads on Tow Ropes**

17. These are:

A + B ( $1/2 \times 14.0$ ) + 6.2 (BE) + 6.2	=	19.4 KN (1.94 tonnes)
A + C ( $1/4 \times 14.0$ )	=	3.5 KN (0.35 tonnes)
A <sub>1</sub> B <sub>1</sub> ( $1/2 \times 0.8.6$ ) + 3.8 + 3.8	=	11.9 KN (1.2 tonnes)
A <sub>1</sub> C <sub>1</sub> ( $1/4 \times 8.6$ )	=	2.2 KN (0.22 tonnes)
Total		<u>42.7 KN (4.3 tonnes)</u>

**Note**

18. These figures will be reduced by the distortion of the net being towed. All six lower corners should be weighted down. I suggest that weights of about 400 kg in total should be used.
19. The above figures are the working loads in ropes and should be multiplied by at least six to determine the breaking loads of ropes to be used.

Farmed Southern Bluefin Tuna Tasting Trial  
Summary of Responses to Questionnaire

Date: 5:00pm, 24, August 1991  
Venue: Foundation Special Function Room

## No. of Responses Received

Age Bracket	Male	Female	Total
20s	4	7	11
30s	14	6	20
40s	12	0	12
50s	19	0	19
60s upwards	6	0	6
Totals	55	13	68

## Re: The southern bluefin tuna used in the tasting trials

Colour	A (Very good)	B (Good)	C (Average)	D (Poor)	E (Very Poor)
20s	3	7	0	1	0
30s	3	9	5	3	0
40s	4	3	5	0	0
50s	2	11	4	2	0
60s upwards	3	2	1	0	0
Totals	15	32	15	6	0

Oiliness	A (Very good)	B (Good)	C (Average)	D (Poor)	E (Very Poor)
20s	5	6	0	0	0
30s	4	8	7	1	0
40s	5	5	0	2	0
50s	10	6	3	0	0
60s upwards	2	3	1	0	0
Totals	26	28	11	3	0

Texture	A (Very good)	B (Good)	C (Average)	D (Poor)	E (Very Poor)
20s	5	5	0	0	1
30s	7	7	4	2	0
40s	4	3	4	1	0
50s	3	12	4	0	0
60s upwards	1	2	2	0	1
Totals	120	29	14	3	2

Freshness	A (Very good)	B (Good)	C (Average)	D (Poor)	E (Very Poor)
20s	7	3	1	0	0
30s	10	9	1	0	0
40s	3	6	3	0	0
50s	10	6	3	0	0
60s upwards	4	2	0	0	0
Totals	34	26	8	0	0

Overall	A (Very good)	B (Good)	C (Average)	D (Poor)	E (Very Poor)
20s	5	5	1	0	0
30s	4	11	5	0	0
40s	4	4	4	0	0
50s	5	12	2	0	0
60s upwards	2	3	1	0	0
Totals	20	35	13	0	0

### Comparisons with other tuna

Colour		1	2	3
20s		Frozen SBT	Fresh farmed SBT	Frozen bigeye
30s			ditto	
40s			ditto	
50s		Fresh farmed SBT	Frozen SBT	Frozen bigeye
60s upwards		Frozen SBT	Frozen bigeye	Fresh farmed SBT

Oiliness		1	2	3
20s		Fresh farmed SBT	Frozen SBT	Frozen bigeye
30s			ditto	
40s		Frozen SBT	Fresh farmed SBT	Frozen bigeye
50s		Fresh farmed SBT	Frozen SBT	Frozen bigeye
60s upwards		Frozen SBT	Fresh farmed SBT	Frozen bigeye

Texture		1	2	3
20s		Fresh farmed SBT	Frozen SBT	Frozen bigeye
30s			ditto	
40s			ditto	
50s		Frozen SBT	Fresh farmed SBT	Frozen bigeye
60s upwards			ditto	

Freshness		1	2	3
20s		Fresh farmed SBT	Frozen SBT	Frozen bigeye
30s			ditto	
40s			ditto	
50s		Fresh farmed SBT	Frozen bigeye	Frozen SBT
60s upwards		Fresh farmed SBT	= Frozen SBT	Frozen bigeye

Overall		1	2	3
20s		Fresh farmed SBT	Frozen SBT	Frozen bigeye
30s			ditto	
40s		Frozen SBT	Fresh farmed SBT	Frozen bigeye
50s		Fresh farmed SBT	Frozen SBT	Frozen bigeye
60s upwards		Frozen SBT	Fresh farmed SBT	Frozen bigeye

3) Do you like tuna?

	Very much	Yes	Average	No
20s	5	5	1	0
30s	8	8	4	0
40s	6	5	1	0
50s	13	5	1	0
60s upwards	5	1	0	0
Totals	37	24	7	0

How many times a week do you eat tuna?

	Less than once	1-3 times	4-6 times	7 or more times
20s	10	1	0	0
30s	15	5	0	0
40s	6	5	1	0
50s	6	12	1	0
60s upwards	3	3	0	0
Totals	40	26	2	0

Freshness	Very good	Good	Average	Poor	Very Poor
20s	7	3	1	0	0
30s	10	9	1	0	0
40s	3	6	3	0	0
50s	10	6	3	0	0
60s upwards	4	2	0	0	0

Graph

Texture	Very good	Good	Average	Poor	Very Poor
20s	5	5	0	0	1
30s	7	7	4	2	0
40s	4	3	4	1	0
50s	3	12	4	0	0
60s upwards	1	2	2	0	1

Graph

Colour	Very good	Good	Average	Poor	Very Poor
20s	3	7	0	1	0
30s	3	9	5	3	0
40s	4	3	5	0	0
50s	2	11	4	2	0
60s upwards	3	2	1	0	0

Graph



Oiliness	Very good	Good	Average	Poor	Very Poor
20s	5	6	0	0	0
30s	4	8	7	1	0
40s	5	5	0	2	0
50s	10	6	3	0	0
60s upwards	2	3	1	0	0

Graph

Overall	Very good	Good	Average	Poor	Very Poor
20s	5	5	1	0	0
30s	4	11	5	0	0
40s	4	4	4	0	0
50s	5	12	2	0	0
60s upwards	2	3	1	0	0

Graph

'93-03-12 (FRI) 10:29 TO 0016186830965

FROM JAPAN TUNA

P01/02

1/2

TELEFAX MESSAGE

FACSIMILE

FEDERATION OF JAPAN TUNA  
FISHERIES CO-OPERATIVE ASSOCIATIONS

TO: TUNA BOAT OWNERS ASSOCIATION OF AUSTRALIA (FAX NO. 08-373-2508)  
ATTN: MR. BRIAN JEFFRIESS

FROM: JAPAN TUNA INT'L DIV.

DATE: 12/03/93

CC: MR. J. TAKAHASHI, OFCF  
MR. KOGA, SBT FARMING PROJECT

SUBJECT: SBT FARMING PROJECT FISH SALE REPORT (NO.8 '93)

DATE: 12/03/93

AWB NO.: 081 8445 3692

SPECIES	:BOX :NO.	:FISH: :NO.	WEIGHT (KG)	:AV. PR. : :(YEN/KG):	AMOUNT (YEN)	: :	NAME OF MARKET
SBT	:636	: 1	: 25.6	: 3,600	: 92,160	:	:TSUKIJI (DAITO)
SBT	:636	: 1	: 18.6	: 4,000	: 74,400	:	:TSUKIJI (DAITO)
SBT	:645	: 1	: 26.4	: 4,300	: 113,520	:	:TSUKIJI (DAITO)
SBT	:645	: 1	: 21.0	: 4,000	: 84,000	:	:TSUKIJI (DAITO)
SBT	:634	: 1	: 25.6	: 3,000	: 76,800	:	:TSUKIJI (TOICHI)
SBT	:634	: 1	: 23.4	: 3,000	: 70,200	:	:TSUKIJI (TOICHI)
SBT	:638	: 1	: 22.0	: 2,700	: 59,400	:	:TSUKIJI (TOICHI)
SBT	:638	: 1	: 17.0	: 1,900	: 32,300	:	:TSUKIJI (TOICHI)
SBT	:632	: 1	: 23.6	: 2,400	: 56,640	:	:KAWASAKI
SBT	:632	: 1	: 17.4	: 2,400	: 41,760	:	:KAWASAKI
SBT	:633	: 1	: 17.4	: 3,400	: 59,160	:	:KAWASAKI
SBT	:633	: 1	: 23.0	: 2,500	: 57,500	:	:KAWASAKI
SBT	:639	: 1	: 26.2	: 4,000	: 104,800	:	:YOKOHAMA
SBT	:639	: 1	: 21.0	: 3,800	: 79,800	:	:YOKOHAMA
SBT	:644	: 1	: 24.0	: 3,800	: 91,200	:	:YOKOHAMA
SBT	:644	: 1	: 15.6	: 3,000	: 46,800	:	:YOKOHAMA
SBT	:643	: 1	: 23.5	: 3,300	: 77,550	:	:SHIZUOKA
SBT	:643	: 1	: 17.5	: 2,800	: 49,000	:	:SHIZUOKA
SBT	:635	: 1	: 23.0	: 3,000	: 69,000	:	:NAGOYA (CENTRAL)
SBT	:635	: 1	: 18.0	: 3,000	: 54,000	:	:NAGOYA (CENTRAL)
SBT	:642	: 1	: 21.0	: 3,300	: 69,300	:	:NAGOYA (CENTRAL)
SBT	:642	: 1	: 17.0	: 2,600	: 44,200	:	:NAGOYA (CENTRAL)
SBT	:631	: 1	: 19.0	: 3,700	: 70,300	:	:NAGOYA (NORTH)
SBT	:631	: 1	: 20.0	: 2,700	: 54,000	:	:NAGOYA (NORTH)
SBT	:640	: 1	: 22.0	: 3,500	: 77,000	:	:NAGOYA (NORTH)
SBT	:640	: 1	: 14.0	: 2,500	: 35,000	:	:NAGOYA (NORTH)

NO. 2

SPECIES	:BOX :NO.	:FISH: :NO. :	WEIGHT (KG)	:AV. PR. : :(YEN/KG):	AMOUNT (YEN)	: NAME OF MARKET
SBT	:637 :	1 :	22.7 :	3,000 :	68,100 :	OSAKA (CENTRAL)
SBT	:637 :	1 :	21.3 :	3,000 :	63,900 :	OSAKA (CENTRAL)
SBT	:641 :	1 :	18.1 :	3,000 :	54,300 :	OSAKA (CENTRAL)
SBT	:641 :	1 :	23.7 :	3,000 :	71,100 :	OSAKA (CENTRAL)
BY MARKET	:BOX :NO.	:FISH: :NO. :	WEIGHT (KG)	:AV. PR. : :(YEN/KG):	AMOUNT (YEN)	: AVERAGE WEIGHT (KG)
TUKIJI (DA.)	: 2 :	4 :	91.6 :	3,975 :	364,080 :	22.9
TUKIJI (TO.)	: 2 :	4 :	88.0 :	2,713 :	238,700 :	22.0
KAWASAKI	: 2 :	4 :	81.4 :	2,642 :	215,060 :	20.4
YOKOHAMA	: 2 :	4 :	86.8 :	3,717 :	322,600 :	21.7
SHIZUOKA	: 1 :	2 :	41.0 :	3,087 :	126,550 :	20.5
NAGOYA (CE.)	: 2 :	4 :	79.0 :	2,994 :	236,500 :	19.8
NAGOYA (N.)	: 2 :	4 :	75.0 :	3,151 :	236,300 :	18.8
OSAKA (CE.)	: 2 :	4 :	85.8 :	3,000 :	257,400 :	21.5
TOTAL	: 15 :	30 :	628.6 :	3,177 :	1,997,190 :	21.0

BEST REGARDS

*National Seafood Centre*

PROJECT NUMBER 6

IMPROVING THE STABILITY AND NUTRITIONAL VALUE  
OF FROZEN SMALL FISH FOR TUNA FEED

FINAL REPORT

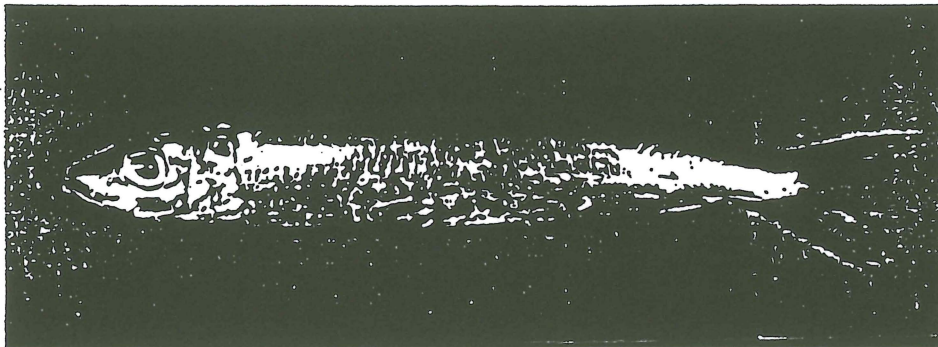

*July 1994*

*Carolyn Fitz-Gerald and Allan Bremner, IFIQ*



## EXECUTIVE SUMMARY

Freshly caught pilchards (*Sardinops neopilchardus*) were obtained from South Australia and subjected to chilled and frozen storage trials in order to determine their stability. The stability was gauged by visual and sensory assessment of the raw pilchards, by sensory assessment of the odour and flavour of cooked samples and by the chemical measures of peroxide value and levels of free fatty acids.

There was considerable variability in fat content between individual fish and overall the average was between 4 to 5% fat.

In chilled storage, the pilchards exhibited obvious deterioration within 2 days. Substantial peroxide values were found and oxidised odours and flavours were clearly evident after 4 days' chilled storage.

In frozen storage, oxidation occurred after only one month at a temperature of -20°C. This could be prevented if the fish were glazed with water. Vacuum packaging in a film of low permeability to oxygen was less effective and is not recommended due to cost.

Pilchards in which oxidation had commenced before freezing continued to oxidise in frozen storage irrespective of whether they were glazed or vacuum packed.

It was thus thoroughly demonstrated that the oil in the pilchards is very readily oxidised and careful handling, chilling, freezing and storage procedures need to be adopted to provide a product which is a nutritionally sound feed material for captive tuna.

## RECOMMENDATIONS

- Pilchards should be chilled as soon as practicable after catch. Ice slurry would make the best medium to chill effectively and inhibit access of oxygen.
- Chilled pilchards should only be used as fresh feed for up to 4 days after catch.
- After landing, the pilchards must be frozen as soon as possible into blocks in a blast freezer.
- Frozen blocks should be glazed with water to prevent access of oxygen and freezer burn (dehydration).
- The temperature of frozen storage should be at least as low as -20°C. Lower would be preferable.
- Frozen pilchards for feeds should not be stored longer than 3 months at a temperature of -20°C.
- Visual and sensory assessment of fresh or frozen pilchards gives a reasonably good guide as to whether the fish have oxidised.