

# Development of Live Fish Transport Techniques



## ***FRDC Projects 93/184 & 93/185***

Final Report

March 1997

M.A. Rimmer and B. Franklin



FISHERIES  
RESEARCH &  
DEVELOPMENT  
CORPORATION

## Table of Contents

Executive Summary .....	2
Acknowledgments .....	5
Glossary .....	6
Publications, Conferences and Workshops .....	8
Introduction .....	10
Section 1 - Capture and Pre-transport Maintenance .....	23
A guide to live fish capture and handling .....	24
Barotrauma and barotrauma alleviation in captured finfish .....	29
Coff design and construction .....	41
Holding system design for live fish facilities .....	50
Recirculating system design for live fish facilities .....	57
Section 2 - Packaging and Live Transport .....	66
Packaging systems for air transport of live fish .....	67
Water quality in live fish transport .....	75
Physiological responses of barramundi to water quality deterioration .....	87
The use of temperature reduction as an aid to the transportation of live finfish .....	97
Removal of carbon dioxide in live fish transport .....	104
Road transport of live fish .....	109
Section 3 - Post-transport Maintenance .....	136
Post-transport maintenance of live finfish .....	137
Appendix 1 - Check list for road transport operations .....	147
Appendix 2 - TPWD specifications for fish transportation tanks .....	148
Appendix 3 - Saturation values for dissolved oxygen .....	150
Appendix 4 - Proportion of unionised (NH <sub>3</sub> ) ammonia .....	151

## Executive Summary

The live fish trade is a rapidly expanding component of Australia's commercial fishing and aquaculture industries. Exports of live Australian finfish have increased steadily over the last 5 years and in 1994-95 were estimated to be worth \$9 million. Marketing of live finfish is regarded as a value adding procedure because live fish obtain substantially higher prices compared with fresh chilled or frozen product. This report provides details of various aspects of live fish transport in these three main areas:

1. Capture and pre-transport maintenance,
2. Packaging and live transport,
3. Post-transport maintenance.

The capture and pre-transport maintenance of live fish requires some modification of techniques traditionally used by commercial fishers and processors. Detailed information is provided on capture and handling techniques, construction and maintenance of live fish holding facilities, and design and operation of recirculating filtration systems.

Barotrauma is an important cause of mortality amongst line caught finfish destined for live fish markets. Coral trout (*Plectropomus leopardus*) and blue throat wrasse (*Notolabrus tetricus*) with severe barotrauma had a consistently higher mortality rate than fish with moderate or mild barotrauma. Coral trout captured in shallow water (0-9 m) exhibited lower mortality than those captured from deeper water (10-19 and 20-29 m). Blue-throat wrasse captured in depths <20 m exhibited very low mortality after capture whereas wrasse captured at 20-35 m exhibited substantially higher mortality. Swim bladder puncture only slightly improved survival in coral trout, providing an overall decrease in mortality of about 10-20% and swim bladder puncture in blue-throat wrasse had no discernible effect on survival.

Four types of restraining material were assessed with regard to their use in coffs: salmon net (knotless) mesh; trawl mesh; plastic oyster mesh; and chicken wire. The coff design that resulted in the least overall damage to fish was salmon mesh, closely followed by the plastic mesh material. Damage levels and mortality rates were higher for coffs constructed with trawl mesh and chicken wire. The economic implications of the use of the various restraining materials is discussed. Based on the results of this experiment, an improved coff design, incorporating a bag made from knotless salmon net cage material and an external frame, was developed to improve survival and fish health during the initial holding phase.

There are basically 3 methods that are commonly used in Australia for transporting live finfish by air:

1. the polystyrene seafood box;
2. the 'pickle barrel' system;
3. the 'big box' system.

Details of these various packaging techniques are provided. 'Purging' fish prior to packing to alleviate water quality degradation during transport is necessary for only 2-3 days.

The major water quality effects experienced by fish during transport are: low dissolved oxygen levels due to oxygen consumption by respiration; accumulation of carbon dioxide from respiration; depression of pH caused by carbon dioxide accumulation; and increased ammonia levels resulting from ammonia excretion. A time-series experiment showed that most water quality degradation occurs rapidly, within the first hour after packing. An experiment to test the effects of containment on fish demonstrated that containment *per se* had no effect on survival, indicating that mortality can be attributed to the changes in water quality that occur during fish transport in closed systems. A manipulative experiment testing various water quality variables indicated that carbon dioxide accumulation is the major limiting factor affecting survival of fish during live transport. High carbon dioxide levels cause hypercapnia, and narcotise and eventually kill the fish.

Although reducing the water:fish ratio improves the economics of live fish transport, it also aggravates the problems of water quality degradation in the transport medium. The physiological responses of seawater-adapted barramundi (*Lates calcarifer*) were studied during simulated live transport and transport under circumstances of elevated carbon dioxide or ammonia. Analysis of blood samples from the fish showed that simulated transport caused the plasma pH of the fish to fall, threatening the blood's ability to transport oxygen, but the red blood cells apparently defended their internal pH and oxygen transport capacity, and swelled measurably as a result. Exposing fish to unusually high carbon dioxide or ammonia levels caused plasma pH to fall to near lethal levels. The effects of both of these wastes need to be considered when studying the responses of fish to live transport.

The use of temperature reduction was evaluated as a method for reducing mortality in live fish transport applications by reducing fish metabolism. Barramundi and banded morwong (*Cheilodactylus spectabilis*) were subjected to slow and rapid cooling regimes of 5 and 8 or 10°C below ambient temperature, and then subjected to simulated transport trials. Most temperature reduction treatments improved water quality significantly. Best survival (89%) of barramundi was achieved by reducing water temperature by 10°C at the slow cooling rate, while for banded morwong, all temperature reduction treatments significantly improved survival.

The use of sodalime to reduce carbon dioxide accumulation in live fish transport applications was evaluated. Prototype live fish transport systems using sodalime were effective in reducing carbon dioxide levels and increasing pH in the transport medium. The prototype systems dramatically increased survival from 31% to 100% for barramundi and from 39% to 90% for banded morwong. Requirements for continued commercial development of these prototypes systems are discussed.

Road transport of live fish is a well established industry in the US and most of the techniques used are readily applicable to Australian conditions with minimal modifications. The information in this report was obtained from published sources

and from conversations with commercial road transport operators in Arkansas, Texas and Louisiana. Some of the salient points discussed are:

- matching truck size and design to specific needs
- use of insulated tanks
- transporting fish in dark or low light conditions
- design of tanks and loading systems to minimise fish handling
- provision of oxygen to compensate for oxygen consumed by respiration
- provision of water agitators to off-gas carbon dioxide
- use of liquid oxygen instead of gaseous oxygen
- provision of adequate amounts of oxygen during the loading procedure, when oxygen consumption is highest
- reduction of water temperature to reduce the metabolic rate of the fish during transport
- extensive pre-transport ‘tempering’ to adapt the fish to transport conditions
- effects of temperature and fish size on loading rates
- recommended loading rates for US finfish species.

Using the procedures and equipment described in this report, live fish transport operators in the US haul fish from the southern central US to markets on the east and west coasts, as far south as the Mexican border, and north into northern Canada. These trips can be up to 5 days in duration. Since the area covered by these operators exceeds the area of Australia, adoption of these procedures and equipment should enable successful road transport of live fish throughout Australia.

The health of transported fish was evaluated with respect to both fish health (bacterial and ectoparasite levels) and levels of potential human health pathogens (*Salmonellae* and *Vibrio parahaemolyticus*) for barramundi and banded morwong. Bacterial levels were low for both species immediately following transport, and 1 week after transport. All samples were well within the required criteria for human consumption. Numbers of ectoparasites varied depending on the source of the fish, but in all cases this was insufficient to cause any fish health problems during the post-transport holding period.

## Acknowledgments

We thank Bryan Hughes (Bicheno, Tasmania) for assistance with experimental work and advice on capture techniques, Joanne de Faveri (QDPI, Biometry Section, Mareeba) for assistance with experimental design and statistical analyses, and Lamie Linton (QDPI, Northern Fisheries Centre, Cairns) for assistance with report preparation.

I thank the persons listed below for their input on procedures associated with the road transport of live finfish. Despite the fact that all those listed were extremely busy with their own work, all willingly gave of their time to provide important information. Thanks also to Chris Barlow (QDPI, Walkamin Freshwater Fisheries and Aquaculture Station) for commenting on the road transport manuscript.

Jack Boettcher, Danbury Fish Farms, Danbury, Texas.

Lee Blankenship, Washington Department of Fisheries, Washington.

David Dunseth, Redfish Unlimited, Palacios, Texas.

Rick Fernandez, LaFourche Mariculture, Golden Meadow, Louisiana.

Wade Finley, Jr., Farm Cat Inc., Lonoke, Arkansas.

Pat Hutson, Director of Programs I, AE Wood Fish Hatchery, Texas Parks and Wildlife Department, San Marcos, Texas.

Bruce Koike, Curator of Collecting, Aquarium of the Americas, New Orleans, Louisiana.

Robert Lindsey, Hatchery Manager, Inks Dam National Fish Hatchery, Burnet, Texas.

Gene McCarty, Director, Coastal Fisheries Division, Texas Parks and Wildlife Department, Austin, Texas.

Mike Ray, Director, Inland Fish Hatcheries, Texas Parks and Wildlife Department, Austin, Texas.

Mike Robison, Brenham Fisheries, Brenham, Texas.

Rob Schmid, General Manager, Simaron Fresh Water Fish Inc., Hempstead, Texas.

Larry Smith, The Bait Barn, Bryan, Texas.

Jim Sutton, Inks Dam National Fish Hatchery, Burnet, Texas.

Dan Thompson, Washington Department of Fisheries, Washington.

Robert Vega, Director, Marine Fish Enhancement, Texas Parks and Wildlife Department, Corpus Christi, Texas.

Max Vickers, East Arkansas Fish Distributors, Hazen, Arkansas.

## Glossary

### *Aeration*

The application of air (*not* oxygen; see 'oxygenation') to water to increase the concentration of dissolved oxygen in the water by diffusion. Air generally contains about 21% oxygen; water contains much less, so oxygen diffuses from the air to the water.

### *Aerobic*

In the presence of oxygen; requiring oxygen. The opposite is anaerobic.

### *Barotrauma*

Over-inflation of the swim bladder, caused by too rapid an ascent from depth.

### *Buffering*

Various compounds in water, particularly carbonate and bicarbonate ions, reduce pH fluctuation. This process is termed buffering.

### *Euryhaline*

Able to tolerate a wide range of salinities, eg. barramundi.

### *Hypercapnia*

Excess of carbon dioxide in the tissues.

### *Hypoxia*

Shortage of oxygen such that body tissue cells fail to receive or are unable to obtain enough oxygen to maintain their normal functions.

### *Nitrification*

The process of conversion of ammonia to nitrite and then to nitrate, undertaken by bacteria under aerobic conditions.

### *Osmosis*

The movement of water across a membrane to a solution of stronger osmotic pressure. Fish must maintain a consistent internal osmotic pressure by actively pumping salts or water from their body tissues.

### *Oxygenation*

The application of oxygen to increase the dissolved oxygen content of water. Unlike aeration, oxygenation may increase the levels of dissolved oxygen in water to greater than saturation values.

### *pH*

pH is a measure of the acidity or alkalinity of a solution. Technically, pH is the negative logarithm of the concentration of hydrogen ions in the solution. The pH scale ranges from 0 (most acidic) to 14 (most alkaline); a neutral pH is 7.0.

### *ppm*

Parts per million. Equivalent to milligrams (thousandths of a gram) per litre.

### *ppt*

Parts per thousand. Equivalent to grams per litre.

### *Respiration*

Respiration is a biochemical process carried out by all living organisms which uses oxygen and produces carbon dioxide. To compensate for these processes, oxygen must be added to and carbon dioxide removed from live fish transport tanks.

### *Saturation*

For any given set of conditions (temperature, pressure, etc.) water will hold only a certain amount of any gas in solution. When the amount of gas in solution reaches its maximal value for those conditions, the solution is saturated with the gas. A solution may be forced to take up even more of the gas, in which case it is termed 'supersaturated'. In the live fish transport field, the concepts of saturation and supersaturation are usually related to oxygen.

*Supersaturation* (See 'saturation').

### *Venting*

Alleviation of barotrauma by puncturing the body wall of the fish with a hypodermic needle or other sharp implement.



## Publications, Conferences and Workshops

Below are listed publications arising from this research, and conferences and workshops at which research results were presented.

### Publications

- de Guingand, P., Rimmer, M., Brouwer, R. and Meikle, G. (1995). Live fish 'on hold' - system design is the key to success. *Australian Fisheries* 54(2), 14-18.
- Evans, L., O'Toole, D., Meikle, G. and Rimmer, M. (1995). Investigations of on-boat handling in the Queensland live coral trout fishery. In: 'Live Seafood Handling: Strategies for Development'. Proceedings of a workshop held at Hobart, Tasmania, 13 October 1995. National Seafood Centre Project 92/125.26. pp. 115-126.
- Paterson, B., Rimmer, M., Meikle, G. and Semmens, G. (1995). Barramundi or moribundi? Interactions between water quality changes and fish physiology during live transport. In: 'Live Seafood Handling: Strategies for Development'. Proceedings of a workshop held at Hobart, Tasmania, 13 October 1995. National Seafood Centre Project 92/125.26. pp. 128-131.
- Rimmer, M. (1995). Development of live fish transport techniques. In: 'Live Seafood Handling: Strategies for Development'. Proceedings of a workshop held at Hobart, Tasmania, 13 October 1995. National Seafood Centre Project 92/125.26. pp. 60-66.
- Rimmer, M.A. (1995). 'Road Transport of Live Fish'. Interim Report to the Fisheries Research and Development Corporation, Projects 93/184 and 93/185. 34 pp.
- Rimmer, M. (1996). Development of live fish transport techniques. In: Barlow, C.G. and Curtis, M.C. (eds). Proceedings of the 1996 Australian Barramundi Farming Workshop, held at Walkamin, Queensland, 10-11 July 1996. pp. 13-15.
- Rimmer, M. (1996). Road transport of fish in the US. *Austasia Aquaculture* 10(2), 41-44.
- Rimmer, M.A., de Guingand, P.F., Meikle, G.M., Franklin, B., Paterson, B.D., Anderson, I.G., Thomas, A., Handler, J. and Hughes, B.K. (1996). Development of improved techniques for the transport of live finfish. In: Hancock, D.A. and Beumer, J.P. (eds.). Proceedings of the Second World Fisheries Congress, 'Developing and Sustaining World Fisheries Resources: The State of Science and Management', Brisbane, Queensland, 28 July - 2 August 1996, vol. 1, p. 125. (abstract).

Rimmer, M.A., de Guingand, P.F., Meikle, G.M., Franklin, B., Paterson, B.D., Anderson, I.G., Thomas, A., Handler, J. and Hughes, B.K. (in press).  
Development of improved techniques for the transport of live finfish. In: Paust, B.C. and Peters, J.B. (eds.). Proceedings of the Workshop on Transport of Live Aquatic Organisms, Seattle, Washington, 12-14 October 1996.

Rimmer, M., Paterson, B. and de Guingand, P. (1994). A guide to live fish capture and handling. Australian Fisheries 53(6), 19-21.

### **Conferences and Workshops**

Transport of Live Aquatic Organisms Workshop, Seattle, Washington, USA, 12-14 October 1996.

Second World Fisheries Congress, Brisbane, Qld, 28 July - 2 August 1996.

Australian Barramundi Farming Workshop, Walkamin, Qld, 10-11 July 1996.

Live Fish Transport Forum, Hobart, Tasmania, 13 October 1995.

Australian Barramundi Farming Workshop, Cairns, Qld, 18-19 August 1994.

Workshop on Live Fish Transport Research and Development, National Seafood Centre, International Food Institute of Queensland, Brisbane, Qld, 26 May 1994.

## Introduction

**M.A. Rimmer<sup>1</sup> and B. Franklin<sup>2</sup>**

1 Queensland Department of Primary Industries, Northern Fisheries Centre, PO Box 5396, Cairns, Queensland 4870.

2 Southern Ocean Products, 'The Gulch', Bicheno, Tasmania 7215.

The live fish trade is a rapidly expanding component of Australia's commercial fishing and aquaculture industries. Exports of live Australian finfish have increased steadily over the last 5 years (Figure 1) and in 1994-95 were estimated to be worth \$9 million. There is also an expanding domestic market for live fish, sold mainly to Chinese communities and restaurants in the capital cities, and this was estimated to be worth \$6.5 million in 1995 (PSM 1995). Marketing of live finfish is regarded as a value adding procedure because live fish obtain substantially higher prices compared with fresh chilled or frozen product.

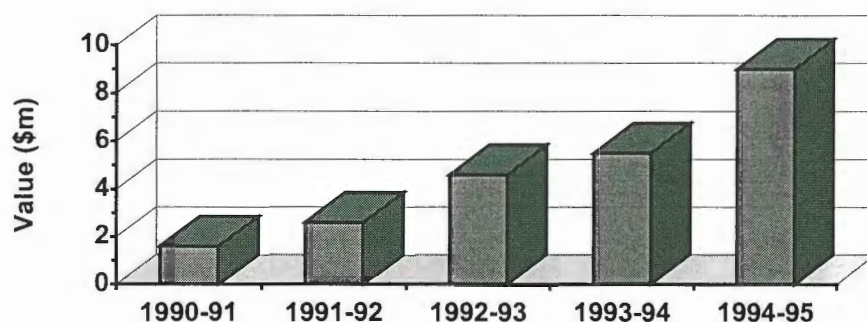

**Figure 1** Value of Australian live finfish exports from 1990-91 to 1994-95 (Grant 1993, PSM 1995).

### **Markets**

The main markets for live finfish products are generally those countries with relatively affluent populations with large numbers of ethnic Chinese. Fish is a symbol of prosperity and good fortune in Chinese culture, and the word 'fish' in Chinese is suggestive of abundance and wealth (Li 1996). Cantonese consumers prefer to eat marine fish that have only recently been killed, and they believe that freshly killed fish have a sweeter flavour and softer texture than fish that have gone through rigour (Li 1996). Consuming freshly killed fish is also believed to bring vigour and good health to the body (Li 1996). Generally, fish are killed and then steamed to avoid changing the flavour and tenderness of the fish. Because of this, species with low fat content, firm flesh and fine-grained skin, such as groupers (Family Serranidae), are

preferred. Cantonese consumers believe that they can readily perceive the subtle taste differences between wild caught and farmed fish, and therefore pay higher prices (usually c. 30% higher) for wild caught fish than for farmed fish of the same species (Li 1996).

### **Hong Kong**

Hong Kong is the largest market for live finfish sourced from Australia. In 1995, Hong Kong imported 28,213 tonnes of live finfish, mostly marine species (Sudari 1996). Australia is a relatively small supplier of live finfish to the Hong Kong market, supplying only 355 tonnes in 1995 (Sudari 1996). The main suppliers of live marine finfish to Hong Kong are China, Taiwan, Thailand, Philippines, Malaysia and Indonesia (Sudari 1996).

In the Hong Kong live marine fish trade, three sectors can be identified (Li 1996, Sudari 1996):

1. the domestic home consumption market,
2. the medium priced restaurant market, and
3. the premium priced restaurant market.

Additional details of the fish utilised in these sectors are listed in Table 2.

#### *Domestic home consumption market*

This market largely relies on the supply from retailing stalls which sell mainly fresh, chilled and frozen fish of demersal species with a retailing price range of AUD\$3-26 per kg. Common live fish species, usually sold by weight, include gold-lined seabream (*Rhabdosargus sarba*), brown-spotted grouper (*Epinephelus bleekeri*) and mangrove snapper (*Lutjanus argentimaculatus*). The retail price range for these species is around AUD\$12-37 per kg and the preferred size range is 0.4-0.8 kg (Li 1996).

#### *Medium priced restaurant market*

This market is the main destination for live marine finfish. In Hong Kong, dining out is important socially and for business. A typical banquet meal may comprise a dozen courses, including at least one of fish, and may take several hours to finish. Steamed fish is often the focus of a conventional wedding banquet, which may require 15-30 fish of the preferred size of 0.6-1 kg to feed a few hundred guests. Demand in this market is for a wide range of fish species, and recently there has been an increasing demand for reef fish such as parrotfish (Scaridae), wrasses (Labridae) and coral trout (*Plectropomus* spp.). Preferred size is 0.4-1 kg, and the wholesale price is around AUD\$9-53 per kg. Fish larger than 1 kg are usually sold by piece (i.e. whole fish) rather than by weight, and bring a lower price per kg (Li 1996).

#### *Premium priced restaurant market*

Some of the preferred species in this market are the humphead Maori wrasse (*Cheilinus undulatus*), giant (or Queensland) grouper (*Epinephelus lanceolatus*), barramundi cod (*Cromileptes altivelis*) and common coral trout (*Plectropomus leopardus*) (Li 1996, Sudari 1996). Preferred size varies with species: for example, giant grouper 30 kg or larger may be shared between 10-20 tables, whereas the

preferred size for common coral trout is around 1-2 kg. Wholesale prices in the premium restaurant market range from AUD\$49 to AUD\$106. This a very dynamic market as different species become popular at different times (Li 1996).

There are significant changes in demand, and hence price, in the Hong Kong live fish market throughout the year (Li 1996, Sudari 1996). Demand peaks each year around the time of festivities such as Chinese new year, around February, and flattens around September (Dragon Search 1996, Li 1996).

An estimated 30% of live marine finfish imported into Hong Kong are re-exported to China (R. Johannes, pers. comm. 1996).

In 1996, the Queensland Department of Primary Industries (DPI) commissioned a study of price and demand in Hong Kong for several species of tropical marine fish that are currently supplied to the Hong Kong live markets from Queensland waters. The results of this study indicate that, while markets in Hong Kong for these high value species are moderate, both price and demand are predicted to increase due to population growth and increasing affluence in Hong Kong and southern China (Dragon Search 1996).

**Table 1** Average wholesale price (AUD\$) and demand in 1995, and projected values for 2000 and 2003, for live marine finfish in Hong Kong (Dragon Search 1996). NA: estimates not available.

	1995		2000		2003	
	Price (\$/kg)	Demand (tonnes)	Price (\$/kg)	Demand (tonnes)	Price (\$/kg)	Demand (tonnes)
Barramundi Cod	87	21	156	42	226	58
Maori Wrasse	87	347	156	700	226	961
Coral Trout	46	446	92	900	133	1234
Flowery Cod	31	} 836	58	} 1,680	84	} NA
Malabar Grouper	21		37		54	
Estuary Grouper	21		37		54	
<b>Total</b>		<b>1,650</b>		<b>3,322</b>		<b>NA</b>

**Table 2** Summary of market information for live marine finfish in Hong Kong (Li 1996).

Demand for	Purposes	Price range (AUDS)	Preferred size	Common species	Supplied from
Domestic needs	Household consumption	<u>Retail:</u> \$12-37 /kg	0.4-0.8 kg,           # not included	Gold-lined Seabream ( <i>Rhabdosarga sarba</i> ) Yellow-finned Seabream ( <i>Sparus latus</i> ) Red Pargo ( <i>Pagrosomus major</i> ) Brown-spotted Grouper ( <i>Epinephelus bleekeri</i> ) Yellow Grouper ( <i>E. awoara</i> ) Mangrove Snapper ( <i>Lutjanus argentimaculatus</i> ) Russell's Snapper ( <i>L. russelli</i> ) Pampano ( <i>Trachinotus blochii</i> ) Rabbitfish ( <i>Siganus oramin</i> )# Rockfish ( <i>Sebasticus marmoratus</i> )# Tigerfish ( <i>Therapon spp.</i> )#	- Mariculture - Importer (culture species) - Inshore fishing boat
Medium-priced restaurants	- Wedding banquet - Business entertainment - Hosting celebrations - Thanksgivings - Family reunions - etc.	<u>Wholesale:</u> \$12-53 /kg	0.4-1.5 kg, <2 kg	Gold-line Seabream ( <i>Rhabdosarga sarba</i> ) Pampano ( <i>Trachinotus blochii</i> ) Brown-spotted Grouper ( <i>Epinephelus bleekeri</i> ) Green Grouper ( <i>E. coioides</i> ) Malabar Grouper ( <i>E. malabaricus</i> ) Tiger Grouper ( <i>E. fuscoguttatus</i> ) Flowery Grouper ( <i>E. polyphekadion</i> ) Parrotfish (Scaridae) Wrasses (Labridae) Coral trouts ( <i>Plectropomus spp.</i> )	- Mariculture - Importer (capture and culture species) - Capture fisheries
Premium-priced restaurants	- Tourists attractions - Wedding banquet - Business entertainment - Hosting celebrations - Showing-off eating-out activities, etc.	<u>Wholesale:</u> \$49-106 /kg	1-2 kg, or above      *excluded	Humphead Wrasse ( <i>Cheilinus undulatus</i> ) Highfin Grouper ( <i>Cromileptes altivelis</i> ) Giant Grouper ( <i>Epinephelus lanceolatus</i> ) Leopard Coral Trout ( <i>Plectropomus leopardus</i> ) Red Grouper ( <i>Epinephelus akaara</i> )* Stonefish (Synanceinae)	- Importer (capture species) - Offshore fishing fleet

## **Taiwan**

The demand for imported live finfish in Taiwan is much smaller than in Hong Kong: in 1994, only 59 tonnes of live marine fish were imported into Taiwan, and most of this product originated from Thailand (Sudari 1996). Most imports were of groupers (83%).

In contrast, to Hong Kong, Taiwanese consumers have a broader preference with regard to live fish products, and marine fish are not as highly valued. In consequence, prices are generally lower. For example, humpheaded Maori wrasse bring only about 75% of the price paid in Hong Kong (Sudari 1996). The main outlet for live marine finfish in Taiwan is restaurants where the preferred size is 0.6-1 kg (Sudari 1996).

## **Singapore**

Singapore is a relatively small market for live marine finfish. In 1994, imports of live marine finfish totalled 1,841 tonnes, most (96%) originating from western Malaysia (Sudari 1996). Barramundi (*Lates calcarifer*) made up more than half of this total, and the rest was made up mainly of snappers and groupers (Sudari 1996). The preferred size of seabass is 600 g, and the average price is AUD\$7-11 /kg (Sudari 1996).

## **Japan**

Although Japan is the largest market for seafood products in the world, the market for live fish products in Japan is smaller than in Hong Kong (Sudari 1996). Japan imports around 5,000 tonnes of live finfish each year (Sudari 1996). Preferred species vary between localities (Kano 1991). Preferred size varies between species: some species are preferred as 'plate size' (300-400 g) while others are preferred in larger sizes (Kano 1991).

## **Other markets**

Although Hong Kong and southern China, Taiwan, Singapore and Japan are the major markets for live finfish, other markets for live seafood products are developing in Asia. Live seafood markets are predicted to expand dramatically in South Korea, Malaysia, Thailand, Indonesia and the Philippines due to high rates of economic growth and increasing affluence, and the presence of significant ethnic Chinese populations (Sudari 1996). For example, imports of live fish into South Korea during the period January-April 1996 increased by 90% in comparison with imports for the same period the previous year (Sudari 1996).

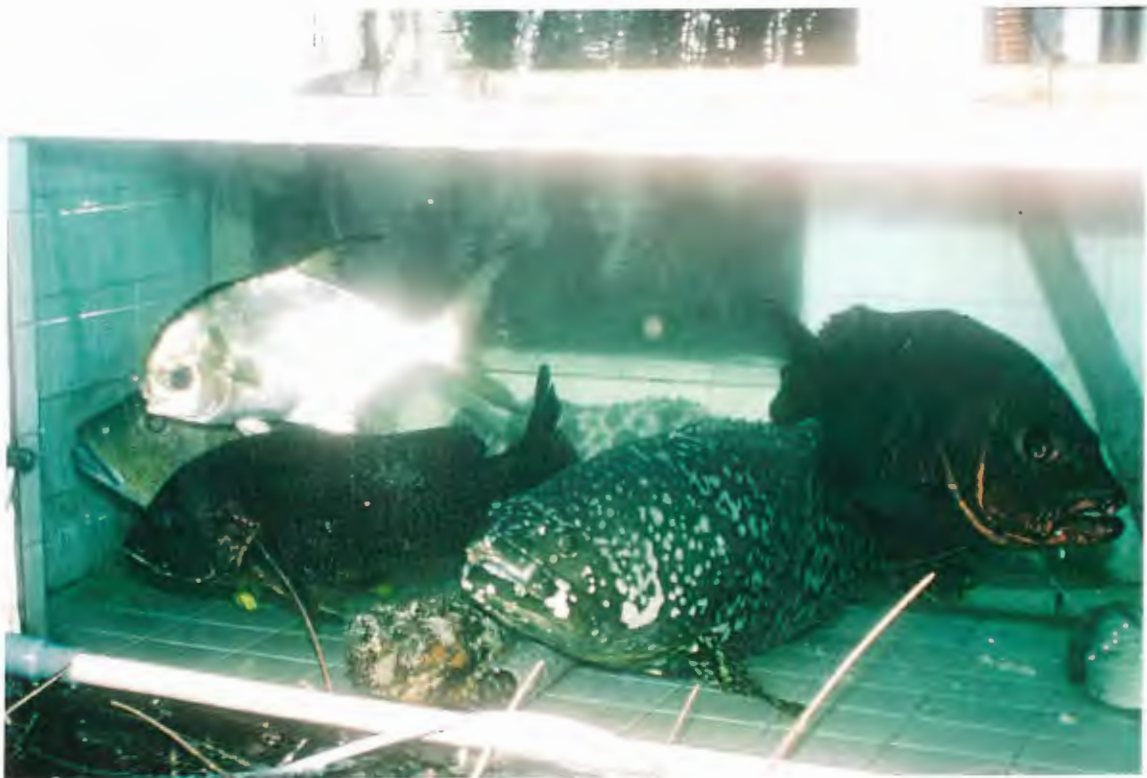

**Figure 2** Live fish display tanks in Hong Kong, showing the diversity of fish species typically displayed.



### **The Australian live fish trade**

Queensland and Tasmania remain the two states where there has been some development of live finfish export sectors. Currently, most Australian export product destined for Hong Kong originates from the Queensland reef line fishery. A recent report on this fishery indicated that there was an increasing trend for fishers in the reef line fishery to target live product at the expense of traditional fresh chilled and frozen fillet products (Turnbull 1996).

The overall amount of live finfish product exported from Queensland is relatively small: around 50-100 tonnes per annum. The Queensland Fisheries Management Authority (QFMA) estimates that only 20-40 fishing vessels are involved in live fish capture, of a total of 1,900 line endorsed vessels (Turnbull 1996). According to Australian Quarantine Inspection Service records, 42.5 t of live fish was exported from north Queensland in 1994 and the QFMA reports that 47 t was exported in the first six months of 1995. Approximately 90 % of the fish exported is coral trout, 4 % is barramundi cod and mixture of other reef species make up the remainder (Turnbull 1996).

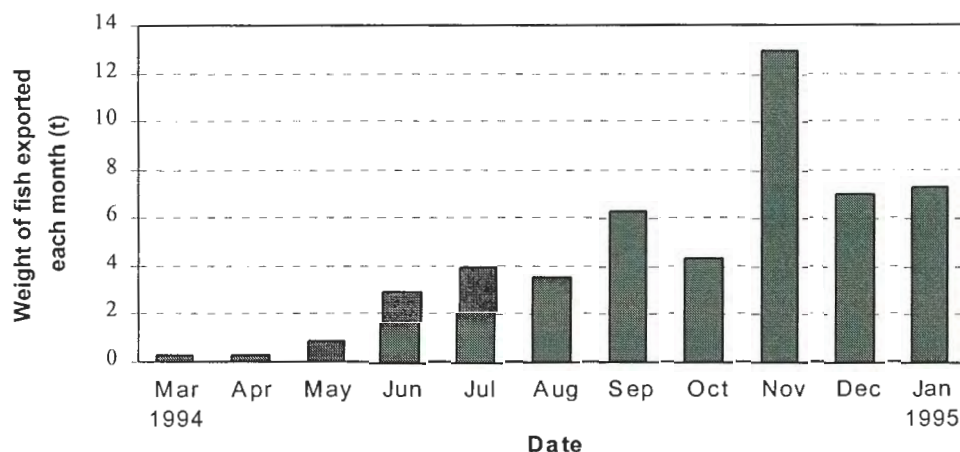

**Figure 3** Live reef fish exported from Queensland in 1994-95, based on AQIS records.

An outline of the processes involved in the Australian live fish trade is shown in Figure 4. Live fish may be supplied either from capture fisheries, or from aquaculture production. After capture, the fish are usually held in short-term holding facilities on the capture vessel or in a 'coff' until enough fish have been retained to provide a useful load for a processor. The fish are usually transported to the holding facility by road; this may involve a trip of several hundred kilometres. The processor will then hold the fish in an on-shore holding facility until there is sufficient product for a load to be sent by road or airfreight to the wholesaler. The wholesaler then provides fish to the end-user, typically individuals or restaurants.

A survey of commercial operators and researchers involved in the Australian live seafood trade was undertaken in 1995. The results of this survey were detailed in PSM (1995).

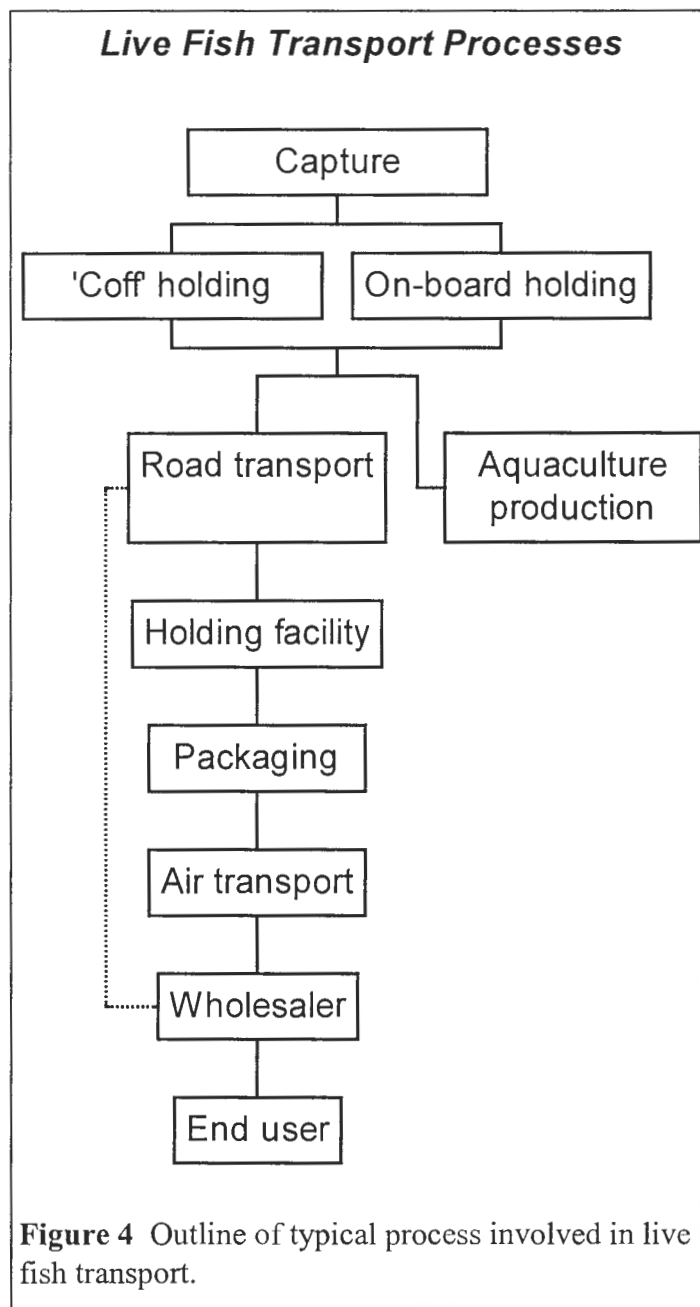

**Figure 4** Outline of typical process involved in live fish transport.

### ***Transport Duration***

Table 3 shows flying times between various domestic and international ports commonly used by Australian live fish exporters. This table can be used to give an estimate of the likely duration of the transport process between various ports. However, it should be noted that the total time from packing to unpacking the fish is considerably longer than this. The packing process itself may take several hours, depending on which packaging system is used. Most airlines require air freight to be delivered 2-3 hours prior to the scheduled departure time. At the destination, the freight must be removed from the aircraft, and in the case of international ports, be cleared by Customs. The containers must then be delivered to the holding facility before they can be unpacked, a process that may take several hours. Overall, these additional requirements add substantially to the total transport time, so that transport durations of 15-20 hours are not uncommon from Australia to South-east Asian destinations.

**Table 3** Flying times (h:mm) between Australian domestic and international ports involved in export and import of live fish (data from QANTAS).

Destination	Origin				
	Darwin	Cairns	Brisbane	Sydney	Melbourne
Brisbane		2:10			
Sydney	3:35	2:45	1:20		
Melbourne		3:10	1:55	1:10	
Hobart					1:05
Hong Kong		6:45	8:15	8:10	8:50
Singapore	4:10	6:00	7:10	7:00	6:05
Tokyo	6:50	6:45		8:50	
Taipei		7:00	9:00	9:25	

### ***Development of Live Fish Transport Techniques***

Because of the continuing demand for live fish, particularly in Asia, there is increasing interest in the live capture and transport of Australian finfish to these markets. The fundamental approach to improving transport techniques is to reduce the amount of water in which the fish are shipped. Air-freight costs are based on weight, so decreasing the weight of water allows a concomitant increase in the weight of fish without any increase in freight costs. This concept is usually expressed as the water:fish ratio (litres of water:kg of fish). Modeling the value of a box of live fish at various water:fish ratios shows that the value increases substantially as the water:fish ratio decreases (Figure 5).

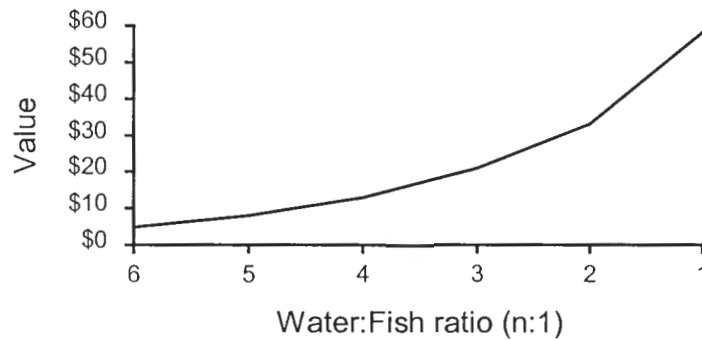

**Figure 5** Change in value associated with decreasing the water:fish ratio for fish transported live. Data points represent the value of a box of live finfish at a nominal value of \$10 /kg.

The overall aim of this project is to decrease the water:fish ratio for live fish transport. At the commencement of this project, commercial water:fish ratios for live finfish ranged from 4:1 to 6:1. Because of the requirement to ship relatively large volumes of water with the fish, exports of live finfish to date have largely concentrated on high-value species, such as coral trout (*Plectropomus* spp.), for which the market price adequately covers the cost of air-freighting relatively large volumes of water with the fish (usually with water:fish ratios of about 5:1).

The development of improved live fish transport techniques will have three major advantages:

1. Expansion of existing export opportunities by allowing economic export of lower valued finfish.
2. Improved profit on existing exports of high-value finfish, or improved ability to withstand market fluctuations as supply increases.
3. Expansion into more distant markets (i.e. with higher freight costs) or markets with lower wholesale prices.

This project was developed in response to requests by industry to improve the efficiency of the live fish trade by improving techniques in use. Two project proposals were amalgamated to develop the final project: one from the Queensland Department of Primary Industries and another from Southern Ocean Products of Bicheno, Tasmania. Although the scientific component of the two proposals was amalgamated to form a single project, administrative arrangements (particularly budgets) were kept separate for the Queensland and Tasmanian components of the project.

### ***Project Objective***

To develop cost-effective techniques for transporting live Australian tropical and temperate finfish.

### ***Project Outline***

This project is divided into 3 major areas of research:

1. Capture and maintenance prior to transport,
2. Packaging and live transport,
3. Post-transport maintenance.

### ***Participating Organisations***

**Table 4** Participating organisations and personnel in FRDC Projects 93/184 and 93/185.

Organisation	Personnel	Role
QDPI, Northern Fisheries Centre, Cairns	G. Meikle*, M. Rimmer, M. Pearce, G. Semmens	Project coordination (M. Rimmer) ; water quality experiments; transport procedures; packaging development.
Southern Ocean Products, Bicheno	P. de Guingand*, B. Franklin, E. MacDougall, B. Hughes	Capture and maintenance techniques; water quality experiments, transport procedures; packaging development.
QDPI, International Food Institute of Queensland, Brisbane	B. Paterson	Stress analyses: lactate, ADP, blood ions.
QDPI, Oonoonba Veterinary Laboratory, Townsville	I. Anderson, A. Thomas	Fish health analyses; microbiology; human health pathogens.
Tasmanian Department of Agriculture, Fish Health Unit	D. Walters	Fish health analyses; microbiology; human health pathogens.

\*Full time technical staff employed on FRDC funding.

## **Contact Details for Participating Organisations**

### **Queensland Department of Primary Industries (QDPI), Northern Fisheries Centre**

Postal Address: Northern Fisheries Centre  
Box 5396 Cairns Qld. 4870  
Phone: (070) 52 9888  
Facsimile: (070) 35 1401

### **Southern Ocean Products**

Postal Address: Southern Ocean Products Pty Ltd  
8 Lovett St., Bicheno Tas. 7215  
Phone: (03) 6375 1588  
Facsimile: (03) 6375 1589

### **QDPI, International Food Institute of Queensland**

Postal Address: International Food Institute of Queensland,  
19 Hercules St, Hamilton, Qld. 4007  
Phone: (07) 268 8555  
Facsimile: (07) 868 1853

### **QDPI, Oonoonba Veterinary Laboratory**

Postal Address: Oonoonba Veterinary Laboratory  
PO Box 1085, Townsville, Qld. 4810  
Phone: (077) 22 2688  
Facsimile: (077) 78-4307

### **Tasmanian Department of Agriculture, Fish Health Unit**

Postal Address: Fish Health Unit, Mt Pleasant Laboratories, Tasmanian  
Department of Agriculture, PO Box 46, Kings Meadows, Tas.  
7249  
Phone: (03) 6341 5389  
Facsimile: (03) 6344 4961

### **References**

Dragon Search Pty Ltd (1996). The Market Analysis of Live Reef Fish Market in Hong Kong and China. Reef Fish Aquaculture Feasibility Study Report No.1, Queensland Department of Primary Industries Information Series QI96105. 120 pp.

Grant, N. (1993). Live seafood trade booms. *Seafood Australia* 6, 27-28.

Kano, I. (1991). Japan - a growing market for live fish. *Infofish International* 3/91, 13-19.

PSM (1995). 'Live Seafood Handling: Strategies for Development'. Proceedings of a workshop held at Hobart, Tasmania, 13 October 1995. Pacific Seafood Management Consulting Group Pty Ltd, National Seafood Centre Project 92/125.26. 136 pp

Turnbull, C. (1996). Domestic reef fishing industry assessment. Reef Fish Aquaculture Feasibility Study Report No.2, Queensland Department of Primary Industries Information Series QI96106. 14 pp.

### **Additional Information**

Copies of Dragon Search Pty Ltd (1996) and Turnbull (1996), as well as other reports prepared for the Reef Fish Aquaculture Feasibility Study, are available from DPI Publications (GPO Box 46, Brisbane, Queensland 4001; Phone: (07) 3239-3772; Fax: (07) 3239-6509; E-mail: [books@dpi.qld.gov.au](mailto:books@dpi.qld.gov.au) ).

Copies of PSM (1995) are available from the Australian Seafood Extension and Advisory Service (AUSEAS) (19 Hercules St, Hamilton, Queensland 4007; Phone: (07) 3406-8617, Fax: (07) 3406-8677).

# **SECTION 1**

## ***CAPTURE AND PRE-TRANSPORT MAINTENANCE***



### **CONTENTS**

#### **A guide to live fish capture and handling**

M. Rimmer, B. Paterson and P. de Guingand

#### **Barotrauma and barotrauma alleviation in captured finfish**

P.F. de Guingand, G.M. Meikle, and M.A. Rimmer

#### **Coff design and construction**

P.F. de Guingand and M.A. Rimmer

#### **Holding system design for live fish facilities**

P. de Guingand, M. Rimmer, R. Brouwer and G. Meikle

#### **Recirculating system design for live fish facilities**

P. de Guingand, M. Rimmer and J. O'Brien



# A Guide to Live Fish Capture and Handling

**M. Rimmer<sup>1</sup>, B. Paterson<sup>2</sup> and P. de Guingand<sup>3</sup>**

- 1 Queensland Department of Primary Industries, Northern Fisheries Centre, PO Box 5396, Cairns, Queensland 4870.
- 2 Queensland Department of Primary Industries, Centre for Food Technology, 19 Hercules St., Hamilton, Queensland 4007.
- 3 Southern Ocean Products, 'The Gulch', Bicheno, Tasmania 7215.

*The following article was originally published in 'Australian Fisheries' magazine, June 1994, vol. 53, no.6, 19-21.*

An area of increasing interest in the Australian fishing industry is the provision of live finfish to markets. The value of live finfish exports has increased steadily over the last 3 years and was estimated at \$4.6 million in 1992-93 (ABARE 1993).

Because live fish are displayed in tanks or aquaria at the point of sale, the retailer expects the product to arrive alive and in good condition. Unfortunately, at present not all Australian processors are meeting these two essential criteria. The Fisheries Research and Development Corporation (FRDC) is currently funding a research program on live fish transport techniques involving cooperative research between the Queensland Department of Primary Industries, Southern Ocean Products in Bicheno, Tasmania, and the barramundi aquaculture industry of Queensland. This research project will investigate physiological and other problems associated with live fish transport and develop techniques to overcome such problems and increase the cost-efficiency of live fish transport operations.

Most fishers are used to operating in traditional capture fisheries where the catch is presented as cleaned or filleted product. Their fishing methods are based on maximising catch per unit effort, and damaged fish can be readily disguised by scaling, skinning or filleting as necessary.

However, the live fish market requires a different approach. Skin and scale damage cannot be disguised, and little recovery is possible during the short time that the fish are in captivity before sale. For this reason, fishers should consider their capture techniques in terms of the specific requirements of the live fish trade, rather than continuing to use procedures that worked well for fresh chilled or frozen product.

One aspect of our research project is the effects of capture technique and pre-transport maintenance on the survival of fish transported live. However, even at this early stage of our research it is clear that some advice on fish handling procedures would be of benefit to fishers wishing to become involved in the live fish trade. Preliminary results suggest that the treatment that the fish receive prior to transport is at least as important as the transport procedure itself. The following provides a guide to optimal handling procedures that should be used in the capture and maintenance of fish destined for live markets.

## Capture

Line fishing or trapping are the best capture techniques for finfish intended for live sale, because the fish are usually not badly damaged by these methods. Physical damage looks unsightly and may lower the value of the fish. A fish's skin and its covering layer of mucus provides a barrier to bacteria and other pathogens, and care should be taken not to damage this delicate tissue. Physical damage to the skin, such as loss of scales, will provide a pathway for infection by pathogenic organisms. Such infections may cause unsightly ulcers at the wound site, and may even cause the death of the fish.



**Figure 1** Live fish should be handled using nets made from knotless material to prevent damage to skin and scales.

Of course, not all fish are amenable to line fishing or trapping, and some species must be netted. Monofilament gill nets, although highly efficient at catching fish, are the most damaging technique that can be used to catch fish. The net material cuts through the skin of the fish, and fish struggling in the net will cause further skin damage and loss of scales.

Whatever the capture method used, the amount of time that captured fish are left in the gear should be minimised to prevent damage. Gill nets may impair respiration by restricting the movement of the gills, resulting in stress and eventual death, so the nets should be retrieved at short intervals (every 1 to 2 hours). The amount of gear in use may have to be reduced to allow more frequent retrieval. Fish should be removed carefully from the net or trap, and every attempt made to reduce skin and scale damage during removal. With monofilament gill nets, the best technique for fish removal is to cut the net to allow the fish to be easily withdrawn from the net.

The rapid change in pressure experienced by fish brought up from even moderate depths may result in overinflation of the swim bladder. This problem varies drastically in extent between different fish species, but is relatively common. Puncturing the swim bladder using a hypodermic needle may help the fish recover, although decompression may be a better option where this is possible. In severe cases of swim bladder overinflation, the gut may protrude from the mouth or anus. In our experience, fish rarely survive if they are this severely affected.

### *Live Fish Vessels*

Dinghies and other vessels used for live fish capture generally have a live well or tank fitted in the boat. A fundamental requirement for captive fish is a supply of clean oxygenated water. This requirement is even more important immediately after capture, when the fish will be highly stressed, will have extremely high respiration rates, and may produce copious amounts of mucus that will cause water quality degradation in the holding tank. Often, this tank is supplied with water from a pipe that picks up water when the boat is in motion. While this system is cheap and reasonably maintenance free, it has one important disadvantage, i.e. there is no water supply to the tank while the boat is stopped. Without a supply of clean oxygenated water to the tank, oxygen levels will drop rapidly in the tank, and the fish will become stressed. If oxygen levels drop low enough, the fish will die.

A better arrangement involves the installation of a pump, such as a bilge pump, which will pump water through the tank even when the boat is stationary. The pump itself should be mounted on the transom to avoid increasing drag, and should be wired to its own battery. The pump should be run whenever there are fish in the holding tank in order to keep the best possible water quality in the tank.



**Figure 2** Stern view of catching dinghy showing 12-volt pump for water supply to live fish well. The use of pumps to supply water to live wells provides better water quality and reduces fish mortality.



**Figure 3** Live fish well in a catching dinghy. Clean water is pumped via an externally mounted bilge pump through the water supply line in the lid, and flows out through a perforated fitting in the bottom of the tank.

### *Holding Facilities*

Once caught, the fish should be held in conditions that minimise stress and maximise survival. Many fishers use “coffs” to hold fish immediately after capture. Coffs are fully enclosed cages, 1-3 m<sup>3</sup> in size, and generally constructed from welded steel mesh. The drawback to such coffs is that the steel mesh causes considerable damage to the fish. As noted above, this may have adverse impacts on the survival and marketability of the fish.

Coffs should be regarded as small scale cages similar to those used to grow out fish for aquaculture, and better coff designs can be constructed by utilising the experiences of the aquaculture industry. Aquaculture nets are made from soft knotless netting material, and coffs should be made from similar material attached to a solid frame. Suitable netting material is readily available from aquaculture suppliers (see section on equipment and material suppliers below).

Netting should be selected in a mesh size large enough to provide adequate movement of water through the cage to provide optimal water quality, yet small enough to prevent escape or entrapment of the fish. The exact mesh size used will depend on the size of the fish to be held. For fish in the range 400 g to 1 kg, a mesh size of 12-17 mm is recommended. Dark coloured nets should be used because dark colours generally reduce fish stress. The growth of marine organisms (biofouling) will eventually reduce water movement into and out of the coff, causing water quality problems inside the coff. For this reason, coffs should be removed from the water and cleaned and dried regularly.

An on-shore holding facility is generally preferable to the use of coffs. Such holding facilities should use plastic or fibreglass tanks of around 3,000-5,000 litres capacity. Both recirculating and flow-through water supply systems are suitable, although operators should become familiar with the operation and maintenance of biofilters subject to shock loading conditions if recirculating systems are used. ‘Shock loading’ is the term used when a large quantity of fish are placed in a recirculating system which was previously only lightly loaded. Under such conditions, the biofilter often has difficulty coping with the sudden increase in load. If pack-out facilities are to be incorporated with the holding facility, temperature control is necessary, and this is most easily met using recirculating systems.

### *General Handling*

Fish should be handled with care to prevent damage to the skin and scales. Always use nets made with knotless mesh, which is available from aquaculture net suppliers. Standard landing nets, which have knotted mesh, are totally unsuitable for handling live fish. Remember that fish live in water, and will dry out rapidly when exposed to air, so air exposure should be kept to an absolute minimum. Fish should always be handled gently; poor handling techniques, such as dropping fish or throwing them into a container, will kill or injure the fish. Picking up fish by hand (e.g. by grabbing the body or the tail) is not recommended because the force needed to keep the fish from jumping free will often severely damage the fish. Never handle fish by sticking your fingers in the gill openings; this will damage the fine tissues of the gills.

### *Materials and Equipment Suppliers*

As noted above, many aspects of capture and handling for the live fish market are similar to techniques used in aquaculture. Aquaculture suppliers are a good source of materials and equipment such as knotless netting, holding cages, etc. A trade directory of Australian aquaculture suppliers is available from AustAsia Aquaculture (PO Box 279, Sandy Bay, Tasmania 7005).

### *Conclusion*

Successful handling of live fish is not difficult; it has been successfully practised by the aquaculture industry for many years. However, to successfully handle live fish it is important to develop good habits, as outlined in this article. Live fish are a 'value added' product, and like all value added products, there are additional costs associated with production. In the case of live fish, these costs are those associated with ensuring that the fish are marketed live and in good condition. Bear in mind that the value being added to this product is life, and only good handling procedures will ensure that the fish stay alive until they reach the end user.

### *References*

ABARE. (1993). Australian fish exports top one billion dollars. Australian Fisheries 52, 14-17.

# Barotrauma and barotrauma alleviation in captured finfish

P.F. de Guingand<sup>1</sup>, G.M. Meikle<sup>2</sup>, and M.A. Rimmer<sup>2</sup>

1. Southern Ocean Products, 'The Gulch', Bicheno, Tasmania 7215.
2. Queensland Department of Primary Industries, Northern Fisheries Centre, PO Box 5396, Cairns, Queensland 4870.

## Abstract

Barotrauma is an important cause of mortality amongst line caught finfish destined for live fish markets. Coral trout (*Plectropomus leopardus*) and blue throat wrasse (*Notolabrus tetricus*) with severe barotrauma had a consistently higher mortality rate than fish with moderate or mild barotrauma. Coral trout captured in shallow water (0-9 m) exhibited lower mortality than those captured from deeper water (10-19 and 20-29 m). Blue-throat wrasse captured in depths <20 m exhibited very low mortality after capture whereas wrasse captured at 20-35 m exhibited substantially higher mortality. Swim bladder puncture only slightly improved survival in coral trout, providing an overall decrease in mortality of about 10-20% and swim bladder puncture in blue-throat wrasse had no discernible effect on survival.

## Introduction

Line fishing is a common method of capturing fish for live markets. Unlike some other techniques, such as gill netting, line fishing generally results in only minor damage to the fish, so capture-related mortality can be relatively low. However, a major cause of mortality in line capture fisheries is over-inflation of the swim bladder, or barotrauma. This condition is the result of physiological constraints associated with the structure of the swim bladder.

Generally, fish with closed swim bladders (physoclistous fishes) are able to maintain hydrostatic pressure as they move up and down the water column at their own pace and in their own environment. This is done through diffusion by a network of capillaries on the wall of the swim bladder or by a resorbant network of capillaries and the gas gland (Lagler *et al.* 1977). Boyle's law establishes that a gas volume expands as pressure decreases, so the contents of the gas bladder will expand as depth decreases. Some fish species can cope with rapid changes in depth, for example lanternfishes (Myctophidae) undertake nightly vertical migrations encompassing changes in depth of 400 metres or more (Lagler *et al.* 1977). These rapid changes in depth are accomplished by the enlarged and highly efficient gas secreting and resorbing structures of the gas bladders of these fish (Lagler *et al.* 1977). However, many fish species cannot cope with rapid changes in depth and if these fish are quickly hauled to the surface after capture, the gas contained within the swim bladder expands faster than the resorbing structures can cope, causing a condition known as barotrauma (Gotshall 1964).

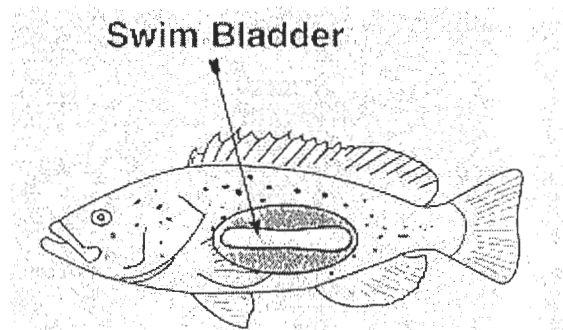

**Figure 4** Diagram showing location of swim bladder in a typical fish (Nolin 1996).

Barotrauma can occur with different degrees of severity. In mild cases, the swim bladder expands and the fish becomes rigid and has difficulty maintaining its vertical position in the water column. In severe cases the swim bladder ruptures, releasing gas into the peritoneal cavity, and the oesophagus everts and protrudes from the mouth or anus (Topp 1963, Gotshall 1964, Parrish and Moffit 1993, Gitschlag and Renaud 1994). Other injuries include the formation of gas bubbles in the blood and organs, exophthalmia, haemorrhaging, and rupture of tissues and organs (Gotshall 1964, Feathers and Knable 1983, Rogers *et al.* 1986, Bruesewitz *et al.* 1993). Often, severely affected fish have difficulty in maintaining equilibrium as well as vertical position. Apart from the likelihood that internal damage to organs and tissue has occurred due to the physical pressure exerted by the swim bladder, fish suffering from barotrauma are subject to stress as they expend energy attempting to maintain a deeper position, or vertical orientation, in the water column. Afflicted fish often fail to recover from severe barotrauma. For example, survival of largemouth bass (*Micropterus salmoides*) captured at depths of more than 18 metres and maintained in lower (surface) pressures was reduced to 60% (Feathers and Knable 1983).

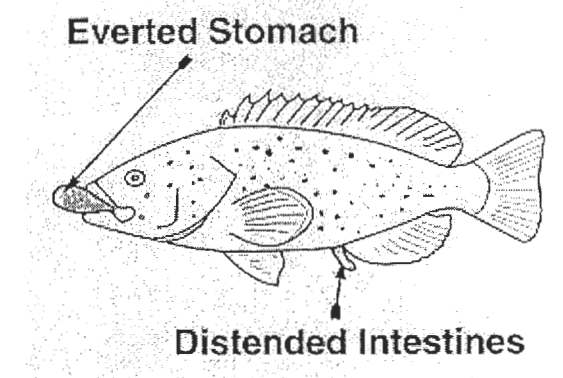

**Figure 5** Fish severely affected by barotrauma, showing everted stomach and intestine (Nolin 1996).

Barotrauma has not previously been regarded as a fishing technique problem in the traditional commercial fisheries for chilled or frozen product. However, barotrauma has long been recognised as a problem in recreational fisheries, particularly those that practise 'catch and

release' (Lee 1992, Talbot and Battaglione 1992, Cribb 1994, Anon 1995, Nolin 1996). The trend toward commercial fisheries capturing fish for live markets has resulted in a greater awareness of the problems caused by barotrauma in keeping fish alive and in good condition (Kronman 1992). The degree of severity of barotrauma is, to some extent, dependent on the depth at which the fish are captured: fish from deeper water tend to have more severe barotrauma and exhibit higher mortality rates (Gitschlag and Renaud 1994). The severity of barotrauma associated with different depths also varies greatly between different fish species, presumably due to anatomical differences (Rogers *et al.* 1986). The fishing technique used also affects the severity of barotrauma; angling usually produces more severe barotrauma than trawling, presumably because the fish are hauled to the surface more rapidly (Rogers *et al.* 1986). Commercial fishers have recognised barotrauma as a capture-related problem, and in many cases have concentrated their efforts in shallow water to reduce the problems associated with barotrauma. However, as fish stocks in shallower fishing grounds become depleted, fishers are having to fish in deeper water and the increased mortality of fish caught from deeper water is reducing catches for the live market.

Some innovative solutions to the problem of barotrauma have been developed by researchers involved in tagging studies. These include: subsurface handling by SCUBA divers the short-term retention of fish in underwater cages (Parrish and Moffitt 1993), and even the use of relatively sophisticated 'decompression chambers' to slowly decompress fish on board the capture vessel (Gotshall 1964). Similar, 'staging' techniques are used by some aquarium fish collectors where the high value of the fish justifies the use of these time and labour intensive techniques (L. Squire Jr, pers. comm. 1996). However, the use of these techniques for line-capture fisheries is generally regarded as impractical.

The practice of using hypodermic needles to puncture the swim bladder and relieve gas tension (also known as 'venting') to increase survival was apparently introduced in the early 1960's (Topp 1963, Gotshall 1964, Moe 1966). An 18- or 20-gauge needle is inserted under the scales, usually just dorsal to the posterior end of the pectoral fin until gas can be heard escaping from the punctured swim bladder (Gotshall 1964, Nolin 1996). Some researchers have also used a round plastic rod with blunt ends inserted into the fish's throat to push the stomach back into place (Gotshall 1964, Parrish and Moffitt 1993). Although the use of hypodermic needles, knives, tagging needles, and other devices to puncture over-inflated swim bladders is generally supported by fisheries research and management authorities (Lee 1992, Talbot and Battaglione 1992, Cribb 1994, Anon 1995, Nolin 1996), in some cases swim bladder puncture has had a negligible effect on subsequent fish survival (Lee 1992, Bruesewitz *et al.* 1993), and in some cases has even been implicated in increased mortality (Gotshall 1996).



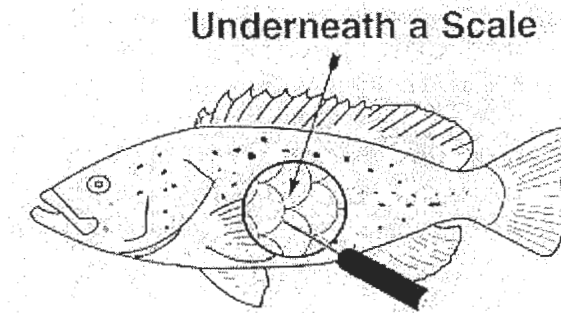

**Figure 6** Diagram showing position of needle used to alleviate barotrauma (Nolin 1996).

Although puncture of the swim bladder is a commonly accepted technique for relieving barotrauma, there is no information on its efficacy in Australian fish species, and relatively few studies from overseas. Consequently, we examined the role of barotrauma in the survival of line-caught fish, and the efficacy of swim bladder puncture as a means of alleviating barotrauma. The aims of this component of the project were to:

1. assess barotrauma as a cause of mortality in line-caught fish;
2. to examine the relationship between barotrauma and capture depth;
3. to determine whether more severe barotrauma is associated with greater mortality;
4. assess swim bladder puncture as a method for reducing mortality due to barotrauma related stress.

### **Materials and Methods**

Coral trout (*Plectropomus leopardus*) in Queensland and blue throat wrasse (*Notolabrus tetricus*) in Tasmania, were used in these experiments. Both these species are targeted by commercial fishers for live fish markets, and are captured using angling gear. Fish used in this study were captured in three depth ranges using monofilament hand lines similar to those used in the commercial fisheries for these species. Coral trout were caught on reefs offshore in the vicinity of Cairns, and blue throat wrasse near Bicheno on the east coast of Tasmania.

After fish were hooked they were retrieved quickly, then placed on a measuring board on a wet foam pad to prevent the removal of mucus and skin by an abrasive surface. The hook was then removed, fish length was recorded, fish were rated for barotrauma and damage level (see ratings below), and every alternate fish was punctured using a 21-gauge hypodermic needle. Fish were punctured below the lateral line where the top of the pectoral fin meets the body when folded back. A scale was lifted and the needle inserted at a 45° angle until escaping gas could be heard. The removal of excess gas was assisted by gentle pressure on the abdomen until the gas had been removed.



**Figure 7** (Above) Blue-throat wrasse (*Notolabrus tetricus*) showing severe barotrauma, where the oesophagus has been everted through the mouth due to internal pressure from the over-inflated swim bladder. (Below) Red snapper (*Lutjanus campechanus*) showing hypodermic needle used to alleviate barotrauma.

Fish were then tagged intramuscularly using a plastic hand held gun with a stainless steel needle and plastic identification tag, and then released into the live well on the vessel. In Queensland, the live tank used was a 700-litre fibreglass elliptical tank which was supplied with a constant flow of fresh seawater using a bilge pump. In Tasmania the live tank used was a 250-litre plastic bin with a hinged lid, with water replaced as required using a bucket. A 12V aerator powered by the boat's battery was used for aeration. Site characteristics (depth and location) were recorded for each fishing location.

*Barotrauma levels*

mild: body normal to touch (coral trout only), upright orientation, swimming normally;  
moderate: body firm to touch (coral trout only), unable to maintain vertical position in water column; difficulty in swimming and maintaining depth;  
severe: body rigid (coral trout only), stomach everted through mouth and/or intestine everted through anus, fish upside down and unable to swim below the surface.

*Damage levels*

- 1 none, or slight damage (eg. minor hook wounds);
- 2 moderate damage (eg. coral or rock grazes);
- 3 heavy / life threatening (eg. hook in throat).

Fish were then moved to a land based facility for fish holding and observation. Mortalities were recorded daily and dead fish were weighed. Post-capture mortality was assessed for 1-3 weeks, until mortality rates appeared to have stabilised.

## Results

### *Barotrauma level and mortality*

The degree of barotrauma shown by the fish directly affects survival (Figure 8, Figure 10). Coral trout and blue throat wrasse with severe barotrauma had a consistently higher mortality rate than fish with moderate or mild barotrauma. Coral trout with moderate barotrauma exhibited higher mortality than coral trout with mild barotrauma (Figure 8), but mortality was similar for blue throat wrasse with moderate and with mild barotrauma (Figure 10). Barotrauma-related mortality stabilised after about 4 days for blue throat wrasse (Figure 10), but took at least a week to stabilise for coral trout (Figure 8).

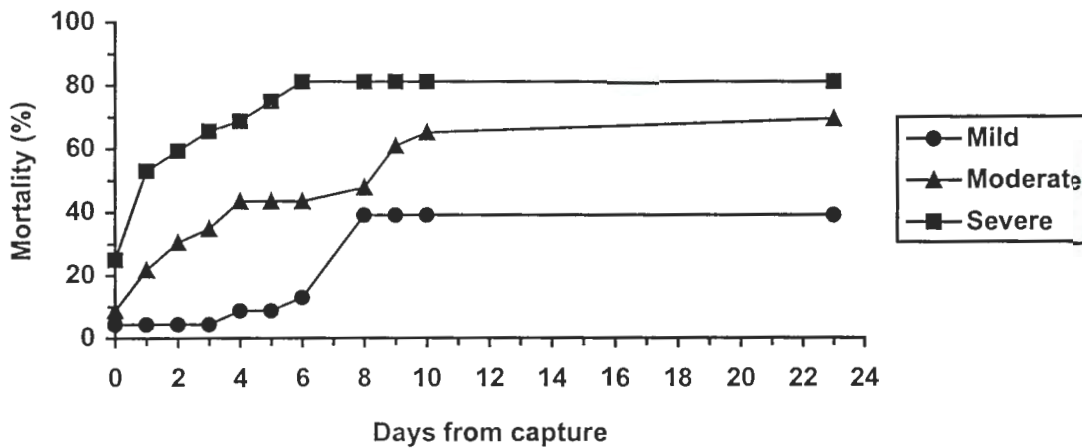

**Figure 8** Cumulative mortality in line-caught coral trout exhibiting various levels of barotrauma at capture. See text for descriptions of barotrauma levels.

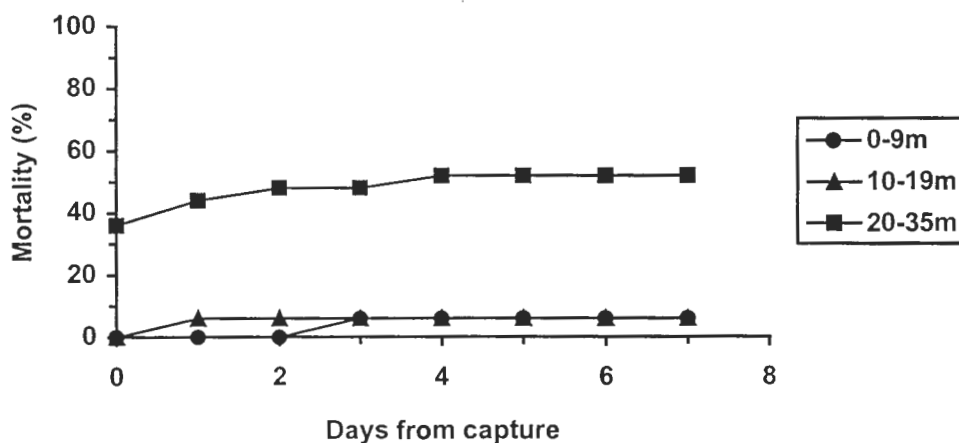

**Figure 9** Cumulative mortality in blue-throat wrasse captured in 3 different depth ranges. See text for details of experimental design.

*Capture depth and mortality*

Mortality was lowest for coral trout captured in shallow water (0-9 m), and increased for coral trout captured from deeper water (Figure 11). Wrasse captured in depths <20 m exhibited very low mortality after capture (Figure 9). In contrast, wrasse captured at 20-35 m exhibited substantially higher mortality (Figure 9).

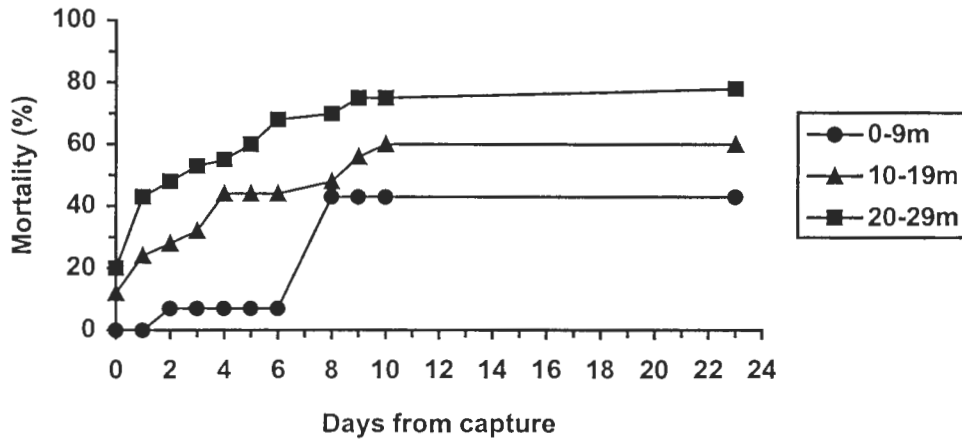

**Figure 11** Cumulative mortality in coral trout captured in 3 different depth ranges. See text for details of experimental design.

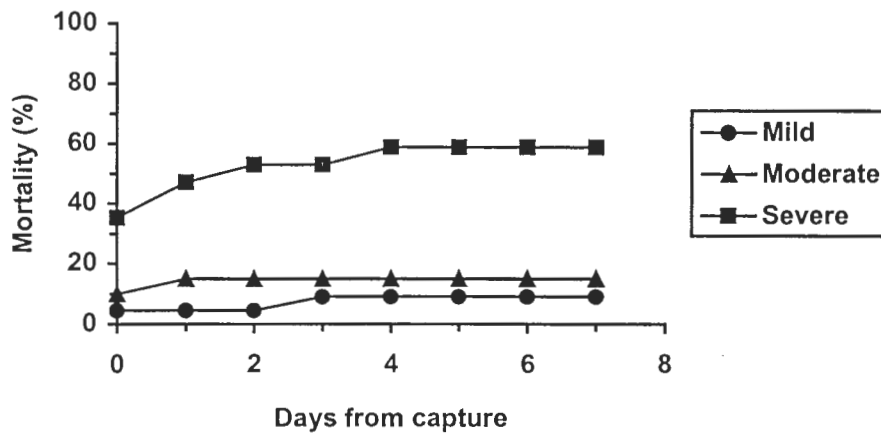

**Figure 10** Cumulative mortality in blue-throat wrasse exhibiting various levels of barotrauma at capture. See text for descriptions of barotrauma levels.

*Efficacy of swim bladder puncture*

Swim bladder puncture only slightly improved survival in coral trout, providing an overall decrease in mortality of about 10-20% (Figure 12). Swim bladder puncture in blue-throat wrasse had no discernible effect on survival (Figure 13).

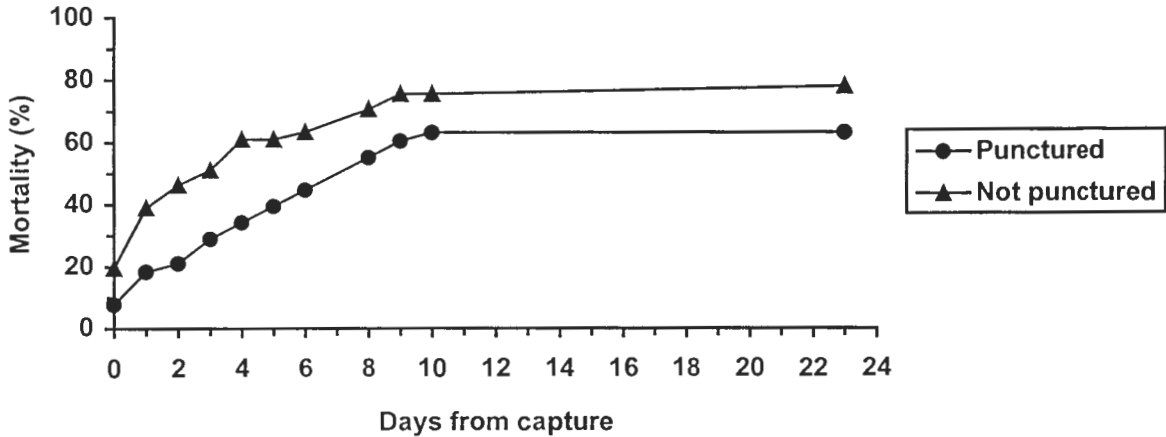

**Figure 12** Cumulative mortality in line-caught coral trout, with and without puncture of the swim bladder to relieve barotrauma.

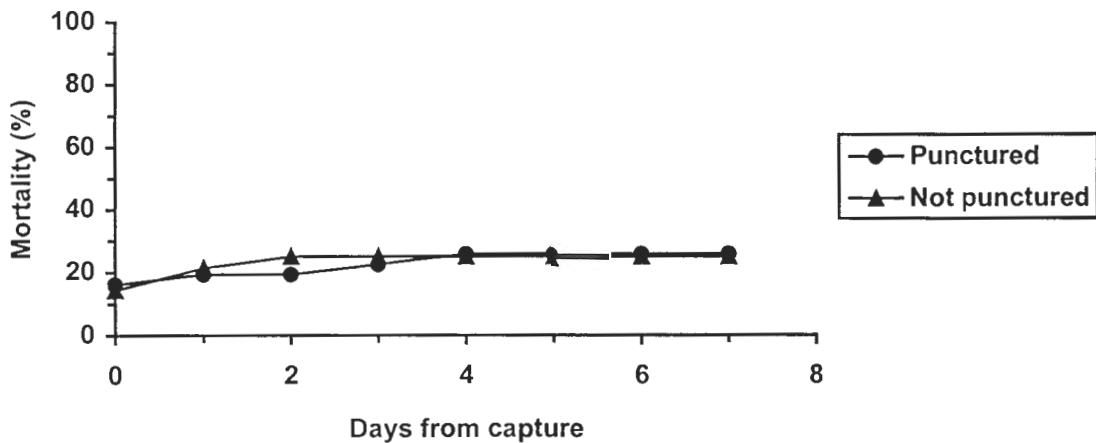

**Figure 13** Cumulative mortality in blue-throat wrasse punctured with a hypodermic needle to alleviate barotrauma, and not punctured.

## **Discussion**

The results of these experiments clearly indicate that barotrauma is an important factor in the mortality of line-caught fish intended for sale as live product. Mortality is most severe in fish caught from deeper water, and these fish generally exhibit more severe barotrauma. A similar relationship between capture depth and mortality has been described for red snapper (Gitschlag and Renaud 1994). Most mortalities occurred within the first 48 hours, but low level mortality continued for 1 week (blue throat wrasse) to 3 weeks (coral trout) before survival stabilised.

There were differences in overall mortality between the 2 species studied. Mortality in blue throat wrasse with severe barotrauma exceeded 50%, while mortality in coral trout with severe barotrauma exceeded 80%. Other fish species, caught as incidental catch in this study, had little response to rapid depressurisation, and did not show the effects of barotrauma. Similar differences between species responses to barotrauma have been described for other studies (Topp 1963, Rogers *et al.* 1986). Rogers *et al.* (1986) suggested that species responses to barotrauma may be caused by: anatomical variation, including skeletal structure and the ratio of swim bladder to total body volume; and the consistency, amount and position of prey material in the alimentary tract. In this study, we noted that even moderate barotrauma in coral trout results in the fish becoming firm to the touch, whereas in blue throat wrasse, even severe barotrauma did not cause the fish to feel unnaturally firm. This is presumably the result of anatomical differences in these fishes, and this may also explain the differential mortality between the 2 species.

The overall mortality rates observed in this study are similar to those observed in other studies of the effects of barotrauma. Feathers and Knable (1983) reported 40% mortality with largemouth bass captured at depths of greater than 18m. Survival of red snapper (*Lutjanus campechanus*) ranges from 50-100% for surface release, and 64-89% for submerged cage release (Gitschlag and Renaud 1984). Commercial fishers in the Queensland reef line fishery claim higher survival rates than those recorded in this study, which may be due to gear modifications and the greater fishing experience of commercial fishers.

The minor difference in mortality between punctured and non punctured fish suggests that injuries sustained and associated with barotrauma are the cause of mortality and these are irreversible in serious cases. A number of other studies have shown that swim bladder puncture has no or little effect on survival of fish affected by barotrauma. Lee (1992) found that puncturing the swim bladders of largemouth bass (*Micropterus salmoides*) with or without barotrauma did not result in greater survival compared with control (unaffected and not punctured) fish. Gotshall (1964) suggested that puncturing the swim bladders of rockfish (*Sebastes* spp.) may have decreased survival because released fish exhibited aberrant behaviour and did not return to conspecific schools. However, a re-analysis of Gotshall's (1964) data by Bruesewitz *et al.* (1993) demonstrated that there was no difference in the return rates of tagged rockfish either with or without puncture treatment. Bruesewitz *et al.* (1993) also found no evidence that puncturing the swim bladder of burbot (*Lota lota*) improved survival.

Most of the studies cited above only considered mortalities directly related to barotrauma, as did the present study, and did not take into account indirect effects, such as increased susceptibility to predation. Upon release, fish that are moderately or severely affected by barotrauma are not

able to swim below the water surface, and will often remain floating at the surface. If released in the wild, these fish are highly susceptible to predation by a wide range of predators, including birds and other fishes. For this reason, swim bladder puncture may be more important in improving survival in recreational fisheries than it is in commercial fisheries. It may also be possible to increase the chances of fish returning to deeper water rather than floating on the surface by releasing fish quickly. Feathers and Knable (1983), Lee (1992) and Bruesewitz *et al.* (1993) all observed that the full effects of depressurisation seemed not to occur if fish were released within a few minutes, and released fish could submerge quickly. However it is unknown whether these fish are more likely to survive or whether they still suffer the injuries associated with barotrauma.

The implications for the live fishery are that as there is a strong correlation between depth fish are caught at and barotrauma level, fishers can make a decision on which areas to fish in with some degree of certainty as to the quality of fish likely to be caught. As survival of fish with moderate barotrauma is still high it is worth fishing in areas which correspond to this depth - 10-20 metres for the species studied in this work.

## **References**

- Anon. (1995). Bladder venting helps save gamefish. Sea Grant News Releases - Tip Sheets, September 1995. [http://www.mdsg.umd.edu/seagrantmediacenter/news/tips/tips\\_sep95.html](http://www.mdsg.umd.edu/seagrantmediacenter/news/tips/tips_sep95.html)
- Bruesewitz, R.E., Coble, D.W. and Copes, F. (1993). Effects of deflating the expanded swim bladder on survival of burbot. *North American Journal of Fisheries Management* 13, 346-348.
- Cribb, A. (1994). Returned believed alive. *Western Fisheries*, Autumn 1994, 46-51.
- Feathers, M.G. and Knable, A.E. (1983). Effects of depressurization upon largemouth bass. *North American Journal of Fisheries Management* 3, 86-90
- Gitschlag, G. and Renaud, M.L. (1994). Field experiments on survival rates of caged and released red snapper. *North American Journal of Fisheries Management* 14, 131-136.
- Gotshall, D.W. (1964). Increasing tagged rockfish (Genus *Sebastes*) survival by deflating the swim bladder. *California Fish and Game* 50, 253-260.
- Kronman, M. (1992). Rod-and-reelers deliver their fish alive and kicking. *National Fisherman*, January 1992, 12-15.
- Lagler, K.F., Bardach, J.E., Miller, R.R. and Passino, D.R.M. (1977). 'Ichthyology'. John Wiley and Sons, New York. 506 pp.
- Lee, D.P. (1992). Gas bladder deflation of depressurized largemouth bass. *North American Journal of Fisheries Management* 12, 662-664.



Moe, M.A., Jr. (1966). Tagging fishes in Florida offshore waters. Florida Board of Conservation Marine Laboratory technical series 49.

Nolin, J. (1996). A guide to releasing reef fish with swim bladder over-expansion injuries. <http://gmv.ifas.ufl.edu/~seaweb/HOME/PAGE/venting.htm>

Parrish, F.A. and Moffit, R.B. (1993). Subsurface fish handling to limit decompression effects on deepwater species. *Marine Fisheries Review* 54, 29-32.

Rogers, S.G., Langston, H.T., and Targett, T.E. (1986). Anatomical trauma to sponge-coral reef fishes captured by trawling and angling. *Fishery Bulletin* 84, 697-704.

Talbot, W., and Battaglione, S., 1992. Fishing for the future - catch and release fishing. NSW Fisheries Fishnote DF/27, 4 pp.

Topp, R. (1963). The tagging of fishes in Florida 1962 program. Florida Board of Conservation Marine Laboratory Professional Papers Series 5.

Whitelaw, W., Campbell, R., Sainsbury, K. and Dews, G. (1991). Fish trapping. *Australian Fisheries* 50(8), 26-29.

# Coff design and construction

P.F. de Guingand<sup>1</sup> and M.A. Rimmer<sup>2</sup>

1 Southern Ocean Products, 'The Gulch', Bicheno, Tasmania 7215.

2 Queensland Department of Primary Industries, Northern Fisheries Centre, PO Box 5396, Cairns, Queensland 4870.

## Abstract

Four types of restraining material were assessed with regard to their use in coffs: salmon net (knotless) mesh; trawl mesh; plastic oyster mesh; and chicken wire. The coff design that resulted in the least overall damage to fish was salmon mesh, closely followed by the plastic mesh material. Damage levels and mortality rates were higher for coffs constructed with trawl mesh and chicken wire. The economic implications of the use of the various restraining materials is discussed. Based on the results of this experiment, an improved coff design, incorporating a bag made from knotless salmon net cage material and an external frame, was developed to improve survival and fish health during the initial holding phase.

## Introduction

'Coffs' are temporary holding pens used by fishers to hold wild caught fish between capture and transport to the holding and packaging facility. The use of coffs provides several advantages over the immediate transfer of fish to the on-shore holding facility:

1. fish can be held in flowing water to evacuate their guts of food (this prevents later pollution of the holding tanks which can dramatically reduce water quality), and
2. fish can be stored in coffs until a sufficient number have been collected to sell to a processor.

Coffs are effectively small cages, generally 1-2 m<sup>3</sup> in volume. It is a requirement of coff design that they be relatively small in size to allow easy access to the fish from a boat. Coffs are usually constructed with a PVC, metal or aluminium frame to which is fitted some form of containing material ranging from welded steel mesh to knotless trawl mesh. Recently coffs made from sheets of plywood with holes drilled through to allow water flow have become popular in Tasmania. Flotation is usually made from plastic or foam buoys or with sealed PVC stormwater pipe, and a lid is usually fitted to prevent bird predation, and to discourage poaching. Fish must be easily accessible to allow mortalities to be regularly removed, so most coffs are less than 1 m deep.

Coffs are mainly used in the Tasmanian live finfish fishery, and the term 'coff' is restricted to Tasmania. In Queensland, similar structures are termed 'cages' or 'pens' (Squire 1994). The use of such structures is now restricted in Queensland, and most boats use on-board holding facilities. Similar short term holding cages have been used for a variety of reasons. 'Tora-fugu' (*Fugu rubripes*) in Japan are stored in holding cages until the winter months when prices may be up to 10 times higher than during summer (Tamura 1966). Yu (1985) made a small towable cage using PVC pipe frames and knotless synthetic net to prevent milkfish damaging

themselves in fish traps as they were transported from one location to another. Despite this, fish still sustained significant enough injuries to result in their death due to movement of their temporary pens (Yu 1985).

Coffs often house fish at high densities, e.g. cofts of 1.5m<sup>3</sup> are stocked with up to 300 kg of fish (200 kg/m<sup>3</sup>). In the authors' experience poor water quality is not usually encountered in cofts as they are generally kept in areas with adequate water flushing. Occasionally however exceptionally slack tides and warmer surface water have been blamed for unexpected mortalities. On occasions, fish whose normal habitat is in deeper water develop cloudy eyes. Bird predation may also be a problem unless the cofts are covered with a solid lid.

Coffs may be used during fishing operations to store fish as they are captured. Once fishing operations are complete the fish are placed into on-board live fish wells for the journey home and the coft is retrieved. This mode of operation is used in both the Queensland and Tasmanian live finfish fisheries (Squire 1994). Where cofts are used to hold fish prior to their collection by processors, most fishers prefer not to hold fish for longer than 7 days. This usually enables the fisher to accumulate enough fish for to make a worthwhile load for the processors. Fishers prefer not to hold fish any longer than is necessary so that mortalities are kept at a minimum, and as net marks become more noticeable after a few days. Mortality rates are highly variable, and most mortality can be attributed to poor coft design, the predominant fault being the type of mesh used in the coft.

At the beginning of the current project we designed an improved coft that had the following features:

- an external frame to prevent damage to the fish coming into contact with the solid frame in attempting to escape the coft;
- a bag made from knotless salmon net cage material to reduce damage due to contact with the mesh, suspended inside the frame so that impact with the mesh was relatively mild due to flexing of the suspended material.

The improved coft design is shown in Figure 14.

Subsequently, we also undertook an experiment to compare different kinds of coft materials in terms of physical damage to the fish and survival of fish in the cofts, and the economic implications of these results for fishers. The materials chosen were those that are commonly used for coft construction in Tasmania. Because coft construction is generally undertaken with whatever materials are available, rather than with consideration for the health of the fish, this experiment was designed to demonstrate the effects that different materials have on the health of fish held in cofts.

### ***Materials and methods***

Four cofts were constructed using 15mm aluminium frame to a standard size of 70 × 70 × 50 cm, or about 0.25m<sup>3</sup> volume. Each coft was covered with a different type of mesh (Figure 14):

1. 17mm salmon net (knotless) mesh, as used for finfish aquaculture cages.
2. 2-inch (50 mm) trawl mesh.

3. 12 mm plastic oyster growers mesh.
4. 2-inch (50 mm) chicken wire.

These materials were selected because they are all currently used in coffs constructed by commercial fishers. Because of limited space and fish availability, replicate treatments were not possible; instead the experiment was repeated 3 times to obtain the necessary number of data. Trials were run for a period of 8 days, which is similar to the duration that fish are held in coffs used commercially.

For these experiments, the banded morwong (*Cheilodactylus spectabilis*) was used as the experimental species. Banded morwong are commonly targeted by Tasmanian fishers for the live trade (Jordan 1994). Fish densities in these experiments were based on those commonly used by commercial fishers. In the first trial 19 fish were added to each coff based on a known average weight of 1.25 kg, giving a density of about 100 kg/m<sup>3</sup>. In the second and third trials fish were weighed into each coff with weights averaging 26 kg/coff. All coffs were randomly tied in a line with approximately 1.5 m between each coff; the two ends were tied alongside the 'Able', a specialised banded morwong capture vessel, so that the coff lid could be accessed from the railing while the coff remained in the water. The fish were dipped from the boat's holding well using a long handled salmon mesh net and placed into the coff, then the lid was firmly tied down.

Once all coffs had been filled the anchor line was tied alongside a dinghy and towed slowly to the point of mooring. A diver then placed the coffs in a north-south line parallel with the protecting island. One end of the anchor line was attached to an unused boat mooring and the other end was weighted to the bottom.

Throughout the trials an underwater video camera and 35mm camera were used for recording coff position and fish every other day. Dead fish were removed daily, as would occur in a commercial situation. A diary was used to record any events such as weather changes, predation, mortality and fish behaviour. In one trial the stitching came unfastened on one coff resulting in the loss of 8 fish. The coff was repaired when it was noticed that the stitching had come undone.

Effectiveness of the different meshes in maintaining fish quality was determined by the number of mortalities and the damage to the fish. Damage was assigned an arbitrary level based on visual assessment:

Damage criteria:

*Mild*: fish with little damage, or scarring, no or little scale loss.

*Moderate*: some scarring, scale loss, or other physical damage.

*Severe*: scale loss or net damage over a large area of the fish, deep scarring turning to ulcers, fish listless, sometimes moribund.

At the end of the trial fish condition was assessed as they were removed from the coffs into a holding vessel on the dinghy. Fish were then brought to the land based holding facility and released into the tanks; any mortality at this stage was also recorded.

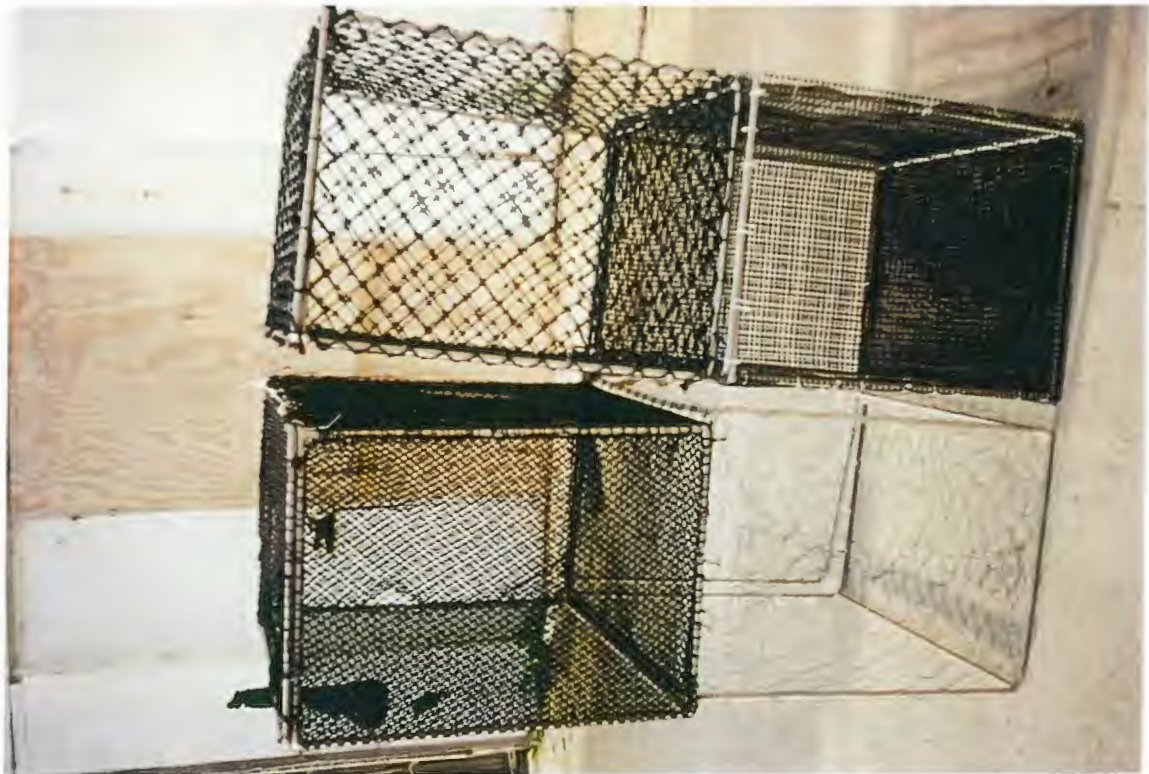
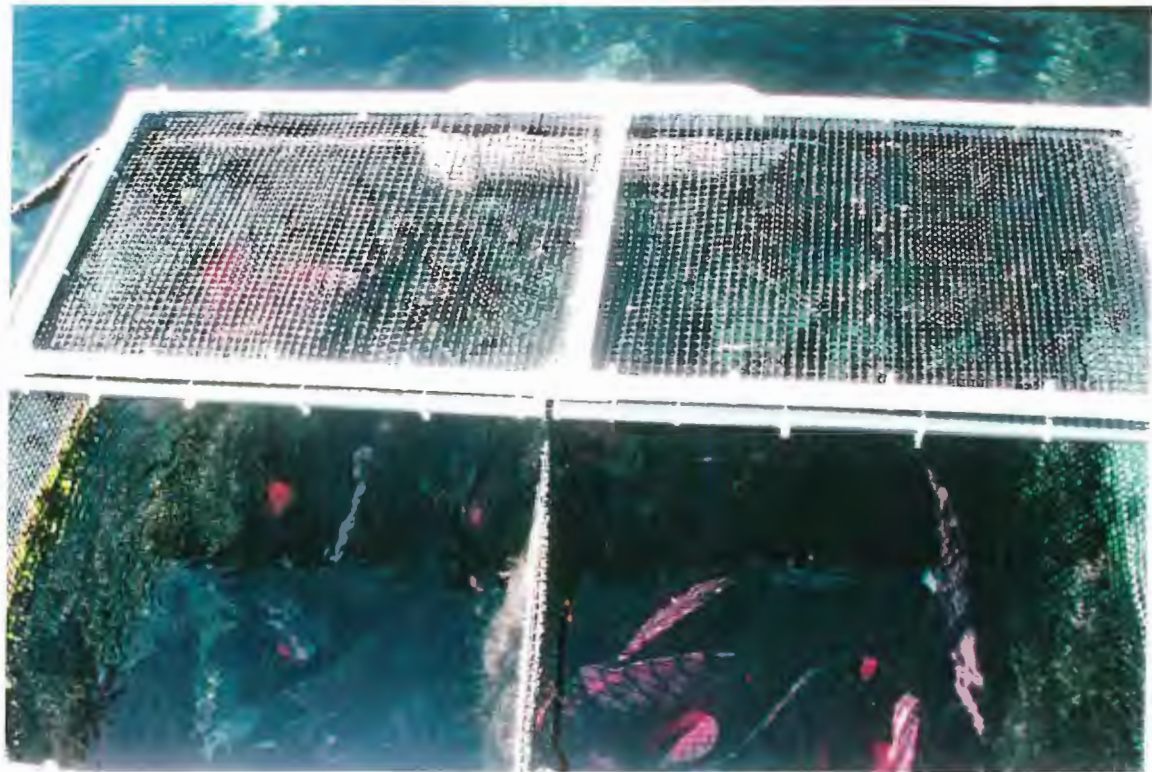
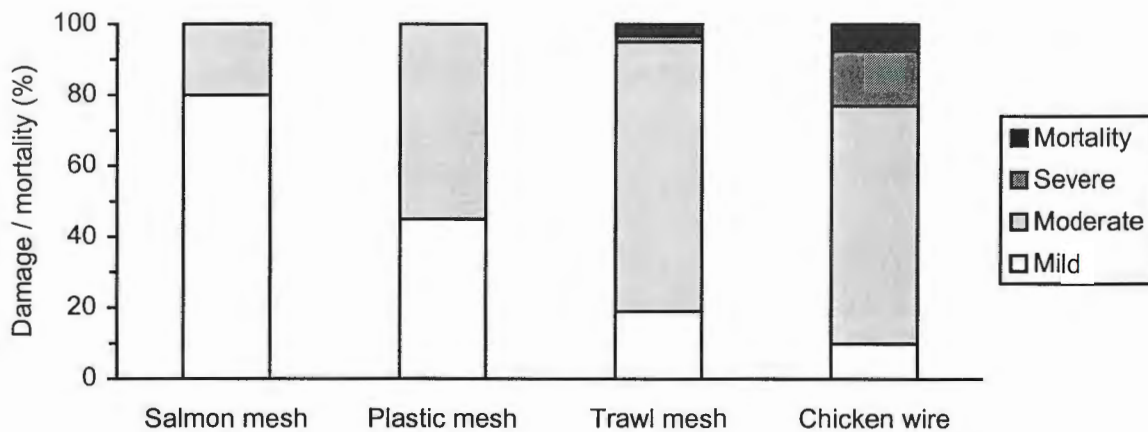

**Figure 14** (Above) Improved coff design, with external frame and knotless salmon mesh netting suspended from frame. Fish in the coff are banded morwong. (Below) Experimental coffs: (clockwise from top left) trawl mesh, plastic mesh, chicken wire, salmon mesh.

## Results

The coff design that resulted in the least overall damage to fish was salmon mesh (Figure 15). Most (80%) of fish held in the salmon mesh coff had only mild damage at the end of the experiment. The remaining 20% had moderate damage. The plastic mesh coff also performed reasonably well, although the results from this material were inferior to those from the salmon mesh coff. Only 45% of banded morwong in the plastic mesh coff had mild damage, and 55% had moderate damage. No fish in these treatments had severe damage, and there was no mortality observed in either the salmon mesh or the plastic mesh coffs.

Both the trawl mesh and chicken wire coffs gave unsatisfactory results (Figure 15). Only 19% of fish in the trawl mesh coff, and 10% of fish in the chicken wire coff, had mild damage. For the trawl mesh and chicken wire coffs, 76% and 67% of fish respectively had moderate damage, and 2% and 16% of fish respectively had severe damage. Mortality rates for these two coff designs were 3% for trawl mesh and 8% for chicken wire at the end of the experiment. An additional 7 fish from the chicken wire coff died after they were transferred to an on-shore holding facility. There were no mortalities from the other treatments during the on-shore holding period.



**Figure 15** Relative proportion of banded morwong suffering from mild, moderate and severe physical damage, and proportion of dead fish, in 4 experimental coffs using different restraining materials.

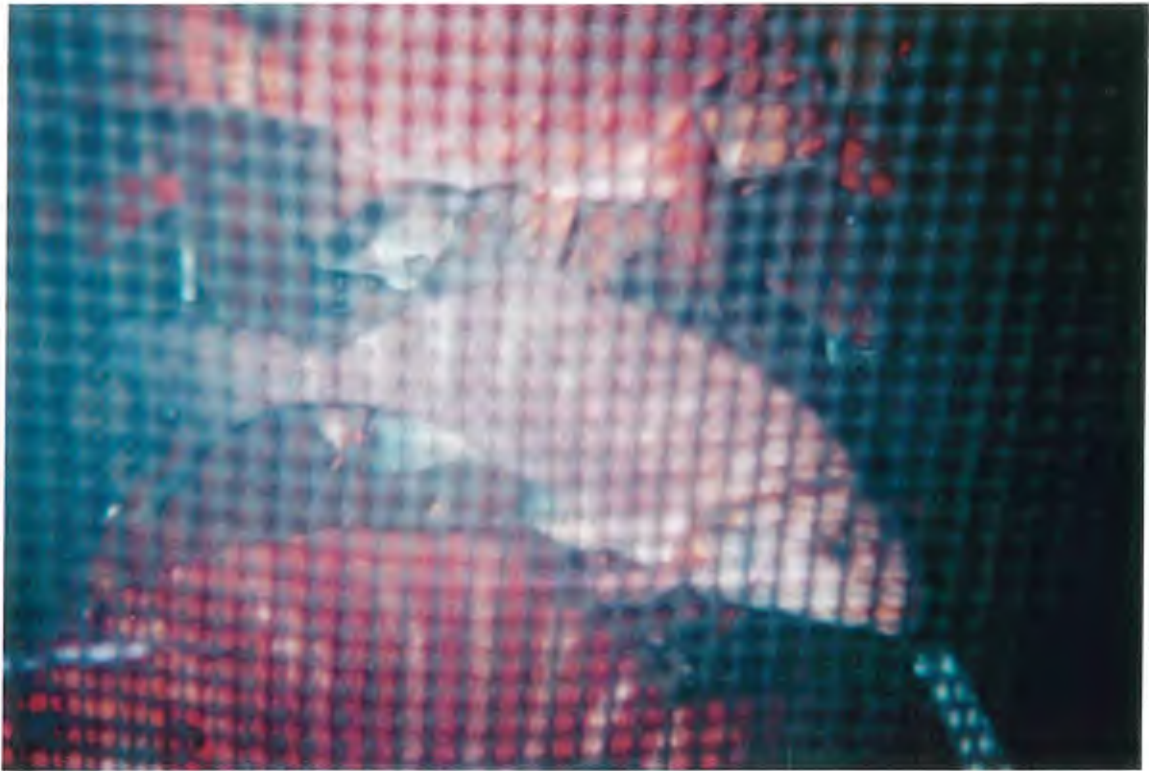

**Figure 16** Banded morwong in (above) plastic mesh coff and (below) trawl mesh coff.



**Figure 17** (Above) Banded morwong in chicken wire coff, and (below) close-up of banded morwong in chicken wire coff showing tail damage caused by abrasion by chicken wire.



## ***Discussion***

These results indicate that the type of mesh used to construct coffs influences the degree of damage incurred by the fish held in the coffs, and also affects survival. Salmon mesh provided the best material for coff construction, and plastic mesh, although inferior in performance to salmon mesh, was also adequate. Coffs made from materials traditionally used in the live fish industry in Tasmania, i.e. trawl mesh and chicken wire, were unsuitable for this purpose. Both these materials resulted in heavy damage to captive fish, and relatively high mortality.

During the experiment it became apparent that the different mesh types had characteristic impacts on the fish even within the same damage categories. For example, fish from the salmon and plastic mesh coffs had noticeable marks on or around the mouths, presumably caused while fish pushed against the mesh in an attempt to escape. Fish in trawl mesh and chicken wire coffs had marks on the top of the snout caused by a similar behaviour. In these types of coffs, the damage was more significant because fish could push their snouts through the larger mesh sizes of the trawl mesh and chicken wire material, causing abrasion of the skin and scales and resulting in more severe damage. In addition, the more open material (trawl mesh and chicken wire) seemed to promote a greater escape response in captive fish.

It should be noted that there were very few occasions when after a trial a fish was removed with no scarring. As banded morwong are caught with gillnets, there was usually scarring that could be attributed to this method of capture. Many fish had marks across the operculum or tail where the fish had struggled in the net and the abrasion had caused damage to the skin and scales. Dorsal fins were also damaged by gillnets: the thin skin surrounding the spines split and eroded exposing the bony spines. It is likely that the observed damage to the dorsal fins of captive fish was the result of damage in gillnets rather than coffs.

The tails of banded morwong were more likely to be damaged in the trawl mesh or chicken wire coffs than in the other designs. Their caudal fins were often worn, split or eroded as a result of mechanical damage incurred while trying to escape through the mesh (Figure 17). In some fish the erosion was so severe that the tail spines were exposed and the caudal peduncle was stripped of scales and skin, and severe haemorrhaging had occurred. A fish was classified as damage level 3 if damage was this severe, and it was unlikely that the fish would survive. Fish in this condition were definitely not saleable as live product.

A basic economic analysis of the differences in fish condition in the different coff types also points out the better performance of the salmon mesh and plastic mesh materials. This analysis is based on typical operations for the live banded morwong fishery in Tasmania. Generally, processors will pay slightly more for fish in better condition. This analysis assumes that mildly damaged fish will achieve the premium price of \$9.00/kg while moderately damaged fish will achieve the slightly lower price of \$8.50/kg. Severely damaged and dead fish are not saleable. These prices were used to determine the value of fish in a coff holding a total of 26 kg of banded morwong, as used in this experiment, based on the proportional damage shown in Figure 15. Results of this analysis are shown in Table 1.

**Table 1** Value of fish in coffs constructed from 4 different restraining materials of the type used in this experiment, with each coff holding 26 kg of fish. See text for details of assumptions used in this analysis.

Damage	Mesh type			
	Salmon mesh	Plastic mesh	Trawl mesh	Chicken wire
Mild	\$187	\$105	\$ 44	\$ 23
Moderate	\$ 44	\$122	\$168	\$148
Total	\$231	\$227	\$212	\$171

The coff with the highest value of fish is the one constructed with salmon mesh, although the plastic mesh coff performs almost as well. The value of the fish in the coff using trawl mesh is around 10% lower than that of the fish in salmon mesh coff, and the value of the fish in the chicken wire coff is dramatically lower. The implications of these results is that coff construction and design impact on the economics of the live finfish fishery by influencing fish condition and survival, and thus the value of the catch.

## References

- Budhabatti, J., and Maughan, O.E., (1994). Cage Designs for Fish Culture in Irrigation Waters. *The Progressive Fish-Culturist* 56,147-148.
- Hoffman, L.C. and Prinsloo, J.F. (1992). The use of holding cages for the spawning of *Clarius gariepinus*. *Water S.A.* 18(3) July 1992.
- Jordan, A. (1994). Species profile - banded morwong. *Fishing Today* 7(3), 34-35.
- Squire, L.C. (1994). Overview of the live and chilled fish export industry in Queensland. Unpublished report to the Queensland Department of Environment and Heritage. 27 pp.
- Tamura, T. (1966). Storage culture of 'Tora-fugu' (*Fugu rubripes rubripes*).13.2.1-13.2.12.
- Yu, O.K. (1985). Layout and design of aquaculture projects: pen and cage systems. AS/AE-CM/85/CP-6, 48-50.

## Holding System Design for Live Fish Facilities

**P. de Guingand<sup>1</sup>, M. Rimmer<sup>2</sup>, R. Brouwer<sup>2</sup> and G. Meikle<sup>2</sup>**

1 Southern Ocean Products, 'The Gulch', Bicheno, Tasmania 7215.

2 Queensland Department of Primary Industries, Northern Fisheries Centre, PO Box 5396, Cairns, Queensland 4870.

*The following article was originally published in 'Australian Fisheries' magazine, February 1995, vol. 54, no.2, 14-18.*

The past few years have seen a considerable increase in the live finfish trade in Australia. The main attraction in selling fish live is the increased return obtained from live fish, because of their greater market value. However, although markets are prepared to pay extra for live fish, this increased value is paralleled by the increase in effort (and cost) to maintain fish in saleable condition. This responsibility must be shared not only by fishers, but by fish processors buying and preparing fish for sale.

A research project to develop cost-effective techniques for the live transport of fish is being carried out by the Queensland Department of Primary Industries, Southern Ocean Products in Bicheno, Tasmania, and the barramundi aquaculture industry of Queensland. This research is funded by the Fisheries Research and Development Corporation (FRDC). A previous article in 'Australian Fisheries' (Rimmer *et al.* 1994) described some ways in which the fisher might improve the quality of fish to the processor. This article is one of two that will outline how processors can keep fish in a premium state up to the point of packing.

### *Stress*

Stressed fish are less likely to survive transport, and are more likely to contract disease prior to being transported. Therefore a major objective in the design of holding systems should be to minimise stress. Visible symptoms of stress in fish include: colour changes, rapid respiration, and behavioural changes, particularly a high degree of 'skittishness'. However, there are numerous more subtle effects of stress in fish that are not visible. These effects include various changes to the blood of the fish that drastically reduce the fish's ability to withstand even moderate changes in water quality. For this reason, fish which are stressed less during pre-transport holding will survive better during transport. The recommendations contained in this article are based on the authors' experience in holding fish in conditions of minimal stress.

### *Fish Collection*

Most processors collect fish from the fisher directly from live tanks on board dinghies, or from fish holding cages known as 'coffs'. Fish are usually collected 'dry' in fish bins, weighed and then put into transport tanks on trucks and taken to land based holding facilities. There is no doubt that the fish are severely stressed, and their health is often compromised, at this point. Leaving fish out of water for any longer than a minute causes considerable stress and may result in hypoxia or suffocation, as fish cannot breathe effectively in air. Often the unloading procedure

is prolonged and the result is a change in the equilibrium of oxygen and carbon dioxide in the blood; this will make the journey in the transporter even more difficult for the fish. The unloading procedure has to be done out of water if it is to remain practicable, however, time out of water must be reduced to a minimum. A soft wet towel on the bottom of the bin will help prevent damage to the delicate skin of the fish.

### *Holding Facilities*

It is possible to separate holding systems into two categories: open (flow through); or closed (re-circulating). The advantages and disadvantages of both types of system are listed below:

	<b>Open</b>	<b>Recirculating</b>
<b>Advantages</b>	Low maintenance requirement 'Shock loading' easily handled	Can manipulate temperature, salinity, etc. Lower pumping costs Not subject to fluctuations in environmental conditions
<b>Disadvantages</b>	Difficult to manipulate environment High pumping costs Reliance on good water quality	High maintenance requirement 'Shock loading' may overload system Acclimation time necessary Requires regular water changes

Recirculating systems require biological filtration to remove nitrogenous wastes that are produced by the fish. These systems are discussed in detail in a separate article.

A fundamental requirement for open holding systems is the availability of good quality water throughout the year. Temperature, salinity and turbidity must all remain within the limits of the species being held if such a system is to be successful.

### *Pumps*

Pump suppliers should be consulted to determine the best pump for a particular application. It is important that the pump be rated for continuous operation. Seawater is particularly corrosive to pumps, so a high level of wear should be expected. Stainless steel impellers will last longer than those made of mild steel. Any electrolysis will rapidly corrode pump parts. Pumps used in recirculating systems should have plastic impellers and plastic impeller housings to prevent the accumulation of iron and other metals in the water. Pumps used for swimming pool filtration systems usually meet these criteria and are commonly used in recirculating systems.

Pumping systems should be designed to provide enough water to replace the contents of each tank every 20-30 minutes. For example, a facility with 6 tanks of 5000 litres capacity each should have a water supply capable of providing  $6 \times 5000$  litres = 30 000 litres every 20-30 minutes, or 60 000-90 000 litres per hour. This figure should include filtration losses, because a filtration system may reduce pumping rates considerably.

### Filtration

It is necessary to filter the water entering the holding facility to prevent the entry of other fish and invertebrates that may carry disease. In areas subject to high turbidity, it is necessary to filter out particulates to increase visibility. It is not practical to filter an intake to prevent the introduction of disease organisms, because filtration to this level is prohibitively expensive to purchase and maintain.

The most suitable type of filtration for fish holding facility intakes is the rapid sand filter. These can be purchased from swimming pool suppliers, although larger holding facilities may require larger, custom-made filters. Rapid sand filters must be backwashed regularly to remove accumulated particulates, but the frequency of maintenance will depend on the specific system design and location, and particularly the turbidity of the intake water.

### Holding Tanks

Most tanks used for holding fish are made from fibreglass or plastic. (Note that fibreglass tanks should be finished with food grade or 'iso' gel coat inside the tank). The development of aquaculture in Australia has resulted in the development of fibreglass and plastic tanks in a range of shapes, sizes, and colours. The shape selected will depend very much on the species being held. For example, banded morwong (*Cheilodactylus* spp.), settle best in tanks of reasonable depth (>80 cm), while flounder require only shallow tanks (<60 cm).

Circular or rounded tanks are preferable as they allow water to circulate freely, while rectangular tanks may develop 'dead' spots in the corners. A particularly useful tank design that is used commonly in the aquaculture industry is the 'Rathburn' tank, which is basically square in shape with rounded corners. These tanks are generally about 3m<sup>3</sup> capacity, and the rounded shape allows for good water circulation. It is best to choose a dark colour (grey or dark blue or green) as dark colours generally reduce stress in fish. However, the tank colour should not be so dark that it makes observation difficult (e.g. black).

Another important feature of tank design is drainage. Tanks that have the drainage point on the base of the tank are easy to empty, and can be flushed with a tap to remove sediments. The level of the tank is determined by either an internal or external standpipe (Fig. 1). Tanks that have the overflow point at the top of the tank are difficult to manage because they must be siphoned to drain or clean the tank. Whatever the location of the outlet, it should be screened



**Figure 18** Different tank designs used in fish holding facilities. In the foreground, a shallow 'Rein' tank ideal for fishes that require little depth, such as flatfishes. Behind, a 'Rathburn' type tank, which is ideal for general use.



**Figure 19** Circular fibreglass tank used for holding barramundi. Note the external standpipe which regulates the water level, the outlet valve used to completely drain the tank, and the horizontal spray bar which promotes circular water movement within the tank.

to prevent dead fish or other objects from blocking the outlet. Blocked outlets will cause overflows, and in recirculating systems, may empty the system and thus damage the pumps.

Inlet and drainage systems are constructed from PVC pipe, which is available in a range of sizes and with various fittings to enable custom systems to be constructed.

Pressure-rated PVC pipe should be used on the supply

system. PVC fittings in larger sizes are relatively expensive, but construction costs can be reduced by using PVC welding instead of standard fittings and by recycling fittings (see box).

Fish should be kept in low light levels, but not in total darkness. Light should enter the tank from overhead, not from the sides, to enable the fish to orientate correctly. Lids should be used on live fish holding tanks to prevent fish from jumping out of the tank, and to reduce light levels. Lids should be perforated to allow some light to enter the tank from overhead.

### *Aeration*

Fish need high levels of dissolved oxygen in the water to minimise stress. Oxygen levels are most effectively maintained by aerating (pumping air into) the water in the tanks. Centrifugal blowers are the most cost-effective aeration systems for large-scale operations, although they are relatively noisy. Blowers also generate enough heat to melt PVC pipes and fittings, so the immediate outlet should be constructed from galvanised metal pipe which will act as a heat dissipating device.

Airlines are usually constructed from black 'poly-pipe' irrigation pipe. Standard irrigation fittings (spray nozzles, etc.) can be used to provide coarse aeration, or, if finer aeration is required, finely perforated compressed rubber irrigation pipe can be used. Fine aeration systems often have a limited life span because the fine pores block with debris or bacterial growth. Fine aeration is more effective than coarse aeration at maintaining dissolved oxygen levels, but fine aeration systems require slightly higher pressure or capacity air blowers because of the greater back pressure produced.

Any aeration system, because it is filled with air, must be weighted to get it to sink to the bottom of the tank. Use only inert materials to weight the lines, such as ceramic electrical insulators or bricks; never use metallic weights of any type.

The only way to be absolutely sure that adequate oxygen is present in the tanks is to purchase a dissolved oxygen meter. Dissolved oxygen meters range in price

### **PVC Welding**

PVC welding techniques are suitable for PVC pipe in non pressure-rated applications, such as drainage systems for marine holding tanks, and even low pressure supply lines. PVC welding requires a heat gun and some PVC welding rod.

Cut two or more pieces of PVC pipe to form the required shape (such as a 90° elbow or T-fitting).

Using the heat gun, melt the PVC rod to seal the joint between the two pieces of pipe.

Another cost-saving technique is to recycle used PVC fittings. Cut the pipe off close to the fitting. Carefully heat the pipe end left in the fitting, which should soften before the fitting itself begins to soften. Once the pipe end has softened, it can be removed with pliers, leaving the fitting intact.

A heat gun can also be used to bend clear acrylic sheet to construct various items of equipment. PVC welding rod can be used to weld the edges of the acrylic sheet to form, for example, clear acrylic tanks.

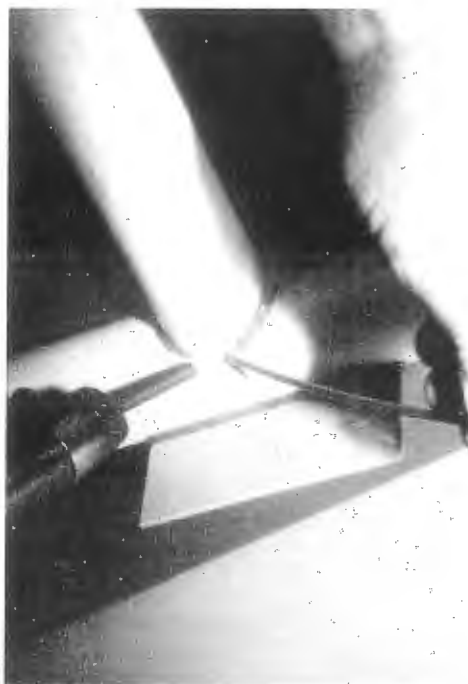

**Figure 20** PVC welding, using a heat gun to melt PVC rod to join two pieces of PVC pipe.

from \$300 to over \$2000 with price usually being a good indicator of quality. A well designed system will run at, or near, 100% oxygen

saturation all the time. Generally, fish will tolerate oxygen levels down to 50% of saturation without any deleterious effects in the short term. Oxygen levels greater than 150% saturation should be considered too high and possibly dangerous. Oxygen levels this high can only be achieved by pumping pure oxygen into the water. Aeration (pumping air into the water) can only raise oxygen levels to 100% saturation.

Another form of aeration sometimes seen in live fish holding facilities is venturi aeration. A venturi device is incorporated in the water supply line to each tank to aerate the water as it enters the tank. While venturi aeration systems are effective, they should not be used as the sole aeration system for a live fish holding system, but used in conjunction with a traditional aeration system.

Occasionally, extremely fine air bubbles may appear in the tanks, giving the water in the tanks a 'cloudy' appearance. This condition is caused by an air leak on the suction side of the pump and

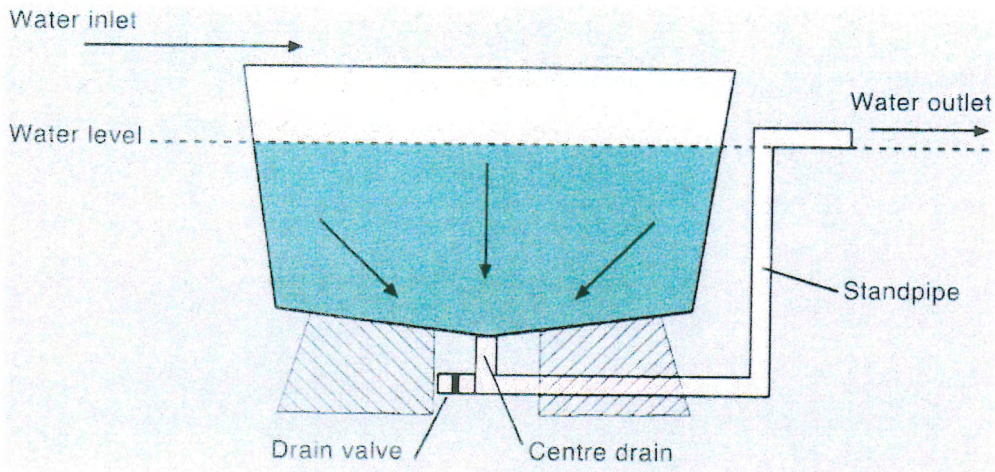

**Figure 21** Lateral view of holding tank showing location of drain and external standpipe. The standpipe regulates the water level in the tank, and the drain valve is used to completely drain the tank when necessary.

is extremely dangerous for the fish, as the fine bubbles may actually penetrate fish tissues and kill the fish.

#### *Temperature Control*

Temperature manipulation is really only achievable in a recirculating system as the costs of effective heating or cooling would be too great in a flow-through facility. If the system is contained in one or two rooms, one option is to insulate the rooms and install a reverse cycle air conditioner. Larger holding facilities may find it impractical to contain the system in a small room. In this case, heaters, chillers, or heat exchangers (which can heat or cool) can be installed to control temperature. The portions of such equipment in contact with the circulating water should be made of material that is relatively inert in seawater, such as titanium or plastic. Galvanised elements should not be used in recirculating systems because zinc may build up to toxic levels. Plastic coating may be used to prevent metal contacting salt water.

#### *Fish Density*

The number of fish that the system will handle depends on the type of fish, and particularly whether or not they will tolerate high densities, and on the efficiency of the holding system. A reasonable rule of thumb (for well aerated tanks) is that for every 1000 litres use 50 kg of fish as a maximum. Higher densities of fish will result in increased incidence of disease. The maximum density of some species depends on their behaviour in captivity. Some species, for example blue throated wrasse (*Notolabrus tetricus*), will tend to fight amongst themselves, and the density may need to be reduced to overcome this problem.

#### *Disease*

Disease is the inevitable consequence of placing stressed fish in tanks at high density. All Australian states now provide disease diagnostic services for fish and other aquatic organisms. Processors should become familiar with the services provided by their local diagnostic service (which is usually provided by the state department of primary industries / agriculture), particularly



the requirements for specimen sampling and submission. Appreciation of the procedures to be followed when a disease outbreak occurs will enable rapid identification of the problem and allow control measures to be instituted as quickly as possible, thus saving valuable fish.

#### *Emergency Power Supply*

Power interruption is one aspect of live fish holding facilities that is frequently overlooked. Any holding facility relies on power for water and air supplies, and even a power interruption of a few hours can result in substantial mortalities amongst the fish being held. At the very least, a generator capable of operating the aeration system should be immediately available. Without aeration, a heavily loaded holding facility will start losing fish within minutes and will have lost most or all stock within an hour. Preferably, the generator should run both the water supply pumps and the aeration system to keep water quality at reasonable levels. Obviously, an automatic cut-in system is required unless the facility is monitored 24 hours a day.

#### *Conclusion*

Fish holding facilities are an artificial environment for the inhabitants, and thus induce stress. The most important principle in the design of holding systems is minimisation of stress. This can be achieved by taking care with the details of design, such as tank colour, light levels, and particularly water quality. Disease outbreaks in such systems are inevitable, and operators should be prepared for such events by liaising with their local fish health service.

#### *Materials and Equipment Suppliers*

Much of the equipment required for constructing a live fish holding facility (tanks, aeration systems, etc.) is available from aquaculture equipment suppliers. A trade directory of Australian aquaculture suppliers is available from AustAsia Aquaculture (PO Box 279, Sandy Bay, Tasmania 7005). Many swimming pool pumps and filters are suitable for use in live fish holding systems.

'Off the shelf' fish holding systems are available from Australian manufacturers, and there are companies that will design and construct commercial fish holding systems.

#### *Reference*

Rimmer, M., Paterson, B. and de Guingand, P. (1994). A guide to live fish capture and handling. *Australian Fisheries* 53(6), 19-21.

# Recirculating System Design for Live Fish Facilities

P. de Guingand<sup>1</sup>, M. Rimmer<sup>2</sup> and J. O'Brien<sup>2</sup>

1 Southern Ocean Products, 'The Gulch', Bicheno, Tasmania 7215.

2 Queensland Department of Primary Industries, Northern Fisheries Centre, PO Box 5396, Cairns, Queensland 4870.

The increasing interest in marketing live fish has led many fishers and processors to install live fish holding facilities, often without a complete understanding of the processes involved in maintaining such systems. Closed-circuit or recirculating systems are particularly popular because they can be located in areas which have sub-optimal water quality, and enable control of environmental parameters such as temperature and salinity. A previous article (de Guingand *et al.* 1995) documented general design aspects of live fish holding facilities; this article discusses the design and maintenance of recirculating systems.

## *Filtration*

An essential requirement for the correct operation of recirculating systems is a functional filtration system. Different types of filters are used to remove various types of fish wastes:

- Biofilters convert toxic ammonia to less toxic metabolites;
- Mechanical filters remove large particles;
- Foam fractionators remove large dissolved organic molecules.

The most important type of filter in a recirculating system, and the most difficult to manage, is the biofilter.

## *Biofilters*

The biological filter (or biofilter) converts toxic fish wastes into less toxic forms. Ammonia is the principle nitrogenous waste product of fish. It is excreted either at the gills, or in faeces, and is particularly toxic in high concentrations. A biofilter simply provides a substrate which allows the correct 'nitrifying' bacteria to oxidise ammonia to nitrite, then to nitrate:

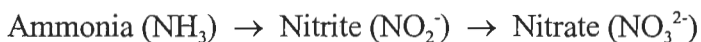

Nitrite can adversely affect fish, but at the concentrations found in commercial marine recirculating systems, nitrite is unlikely to reach critically high levels. Nitrite is further oxidised in the biofilter to form nitrate, which is effectively non-toxic in these systems.

The substrate, or medium, for a biofilter must meet certain criteria:

- It should have a large surface area to maximise the attached bacterial population per unit volume.
- It should have a large void space to allow gas exchange throughout the filter and to prevent blockage or channeling.
- The media should be made up of inert materials - plastic and calcareous media are suitable, but metals or other materials which are affected by salt water are not suitable. Any medium should be flushed before adding fish to the system in case of any residual toxic compounds.

- It should not act as a mechanical filter (see below) as this will ultimately harbour the incorrect populations of bacteria and the filter will rapidly clog.
- At least some of the media used in the filter should have some buffering capacity in saltwater, or else the pH of the water will decrease. Calcareous material such as shell grit or coral gravel is ideal.

Some firms offer specially developed inert plastic biofilter media (e.g. 'bioballs', 'biocubes') which are ideal, providing a large surface to volume ratio and large void space (Figure 22). These plastic media are expensive, although once purchased they have an effectively unlimited life, provided that they are not exposed to sunlight for prolonged periods. Cheaper types of media may break down rapidly and require regular replacement.

The exact size of the biofilter can be determined from the operating characteristics of the substrate used, the operating temperature of the system, the biomass of fish and the amount of ammonia excreted by the fish. In reality, this information is rarely available, so the rule of thumb is that the biofilter capacity should be 5-10% of the total system capacity. (Another rule of thumb is that, if in doubt, go with the largest possible filter size).

Inert media have no buffering capacity, so it is necessary to add calcareous material such as coral rubble, or crushed oyster or scallop shell to help buffer the water and reduce changes in pH. This material should be graded to a size range of 5-10 mm in order to provide a reasonably large surface-volume ratio while providing enough void space to reduce clogging.

A simple and effective form of biofilter which is becoming increasingly popular is the trickle filter (Figure 23). This type of biofilter is commonly used for aquaria and its design has been adapted for use in commercial fish holding facilities. Water is pumped into the top of the filter, trickles down through the media, and collects at the bottom of the filter before being returned to the system. Trickle filters should be elevated above the holding tanks, so that the water can gravity-feed back to the tanks after being filtered. The media in a trickle filter is well aerated, since most of it is not submerged, and this results in better gas exchange and higher dissolved oxygen levels compared with submerged filters. A spreader plate (a solid plate with holes drilled at regular intervals) at the top of the filter ensures that water is distributed evenly throughout the filter, which increases the efficiency of the filter (Figure 22).

An important factor which affects biofilter performance is temperature. Generally, biofilters function more efficiently at higher temperatures. At very low temperatures, the efficiency of biofilters declines dramatically and nitrification is negligible below about 5°C.

Sand filters can be used as biofilters if the sand filter is run at half its rated capacity. However, these filters have a much higher maintenance requirement than dedicated biofilters, and require regular backwashing.

Because biofilters rely on bacteria to remove ammonia, any treatment of the water which affects bacteria (such as the use of antibiotics) will 'kill' the biofilter. (Note that no chemicals, including antibiotics, are currently registered for use in food fish in Australia).

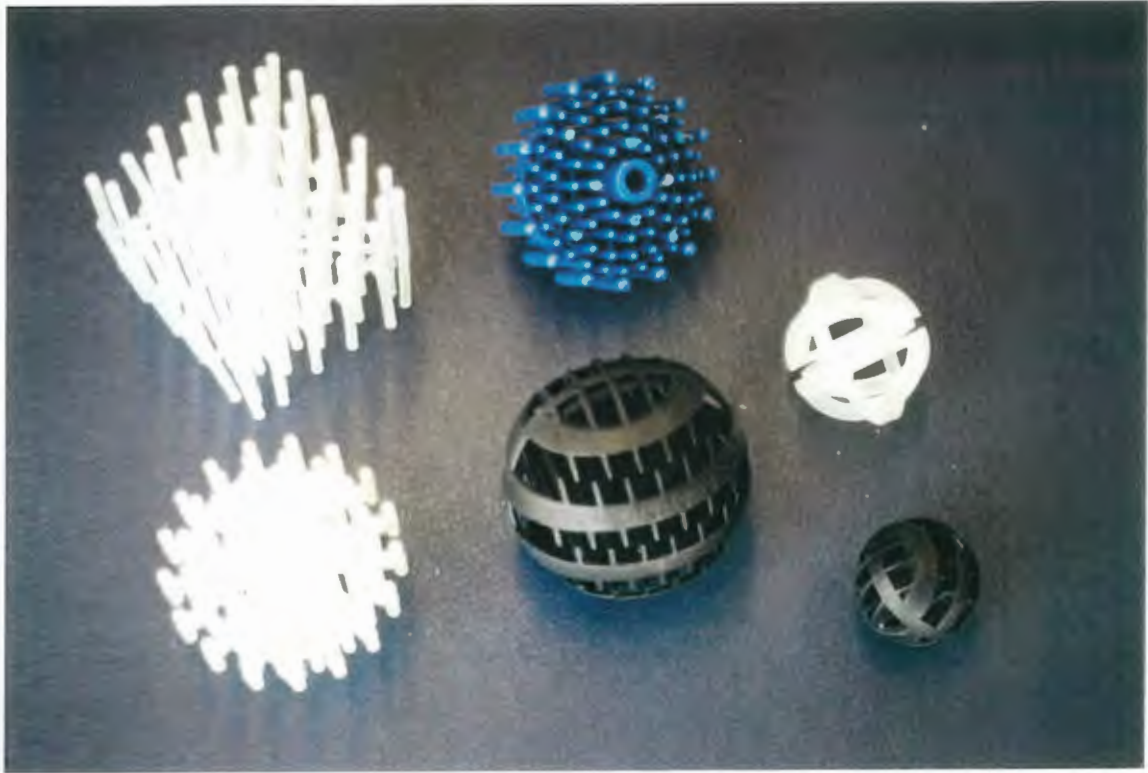

**Figure 22** (Above) Examples of the different types of plastic filter media used in biofilters. (Below) Spreader plate on a trickle type biofilter used in a 20,000-litre recirculating system at Northern Fisheries Centre, Cairns. Media used is 80% plastic media ('biocubes') and 20% coral gravel. Water is pumped in at the top of the filter, trickles through the biofilter, and is drained from the bottom of the tank. The perforated spreader plate at the top of the filter ensures that water is spread evenly throughout the entire filter. This particular recirculating system also uses a sand filter for mechanical filtration of particulates, and a foam fractionator.

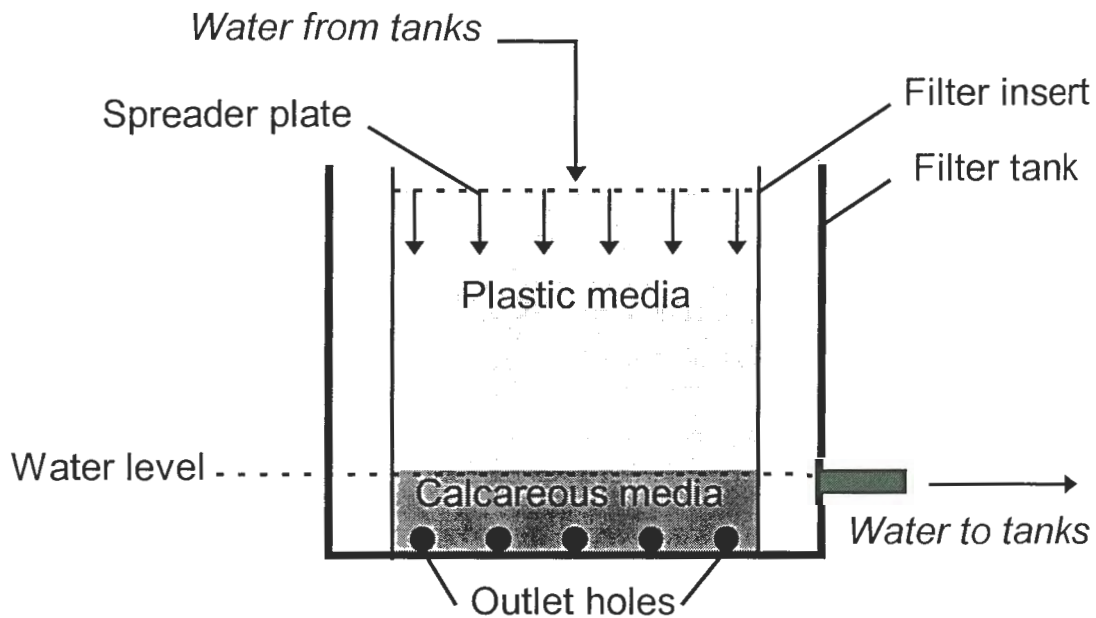

**Figure 23** Diagram of a trickler filter showing the filter insert inside the filter tank. Arrows indicate the direction of water flow. Water from the holding tanks is pumped in at the top of the filter, where a perforated spreader plate ensures that the water is spread evenly over the top of the filter. The water trickles down through the filter media (in this case, a combination of plastic media and calcareous material) and out through the holes in the bottom of the filter insert. The water then gravity feeds back to the holding tanks.

#### *Acclimation of the biofilter*

One of the main problems with recirculating systems is the time required to build up enough of the appropriate nitrifying bacteria to cope with the ammonia accumulating in the system. This time is known as the acclimation, or start-up time. Acclimation is generally faster at higher temperatures ( $> 25\text{ }^{\circ}\text{C}$ ) when it may take place in 20-30 days. At lower temperatures (10-20  $^{\circ}\text{C}$ ) a biofilter may take up to 60 days to acclimate. An example of the levels of ammonia, nitrite and nitrate experienced during acclimation of a biofilter is shown in Figure 24. As levels of ammonia and nitrite will reach very high levels until acclimation, it is important that the tanks are not heavily stocked during this time as significant mortality may result from degradation in water quality.

Acclimation time can be reduced by ‘seeding’ the filter, i.e. adding some substrate material from an operating biofilter. The seeding material should already contain a population of the desired bacteria, which will rapidly proliferate within the new biofilter. Naturally, the operating recirculating system should be free of disease before any material is removed from it. Another procedure which will decrease the acclimation time for biofilters in cold water systems is to heat the water to about 25°C until the filter has acclimated, then gradually decrease the temperature over a few days until the system reaches the desired operating temperature.

Acclimation of the biofilter should be undertaken by adding an inorganic source of both ammonia and nitrite to the biofilter to supply a source of nutrients for both stages of the process which converts ammonia to nitrate. This is undertaken by adding a single dose of ammonium chloride ( $\text{NH}_4\text{Cl}$ ) and sodium nitrite ( $\text{NaNO}_2$ ) at approximately 20 g of each chemical per 1000 litres of system water. An aquarium test kit should be used to monitor levels of ammonia and nitrite; the system can be stocked once levels of both ammonia and nitrite have dropped to near zero.

Some firms offer ‘broths’ of concentrated bacteria, which can be added to the system to hasten acclimation, but there are conflicting reports on the success of such products. Bacteria not attached to the filter substrate do not contribute significantly to the nitrification process, and because the bacteria in these broths are not attached, they have generally proven unsatisfactory for seeding biofilters. On a similar note there are products that claim to be able to remove ammonia or other substances from the water. Some of these compounds have been shown to have no effect on fish survival, so their value is questionable. Any such additives should always be tested first by the user so that their effectiveness can be assessed.

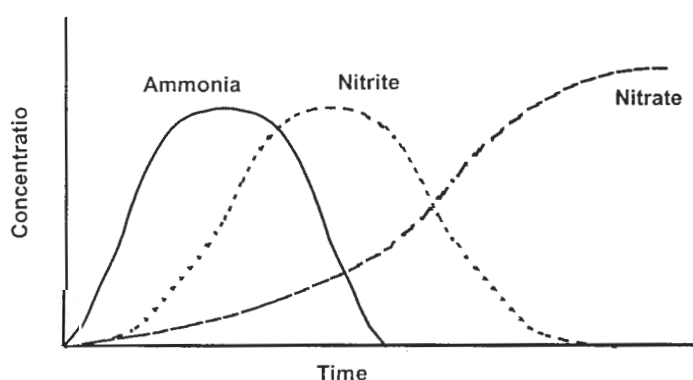

**Figure 24** Typical response of ammonia, nitrite and nitrate concentrations during the acclimation phase of a biofilter. As described in the text, the time taken for ammonia and nitrite levels to decrease to near zero will depend on several factors, especially water temperature.

### *Monitoring Recirculating Systems*

It is important to monitor the performance of the biofilter to successfully manage recirculating holding systems. If the biofilter is operating correctly the system will have negligible levels of ammonia and nitrite, and low to moderate levels of nitrate. Recommended levels of these parameters are listed in Table 1. If any water quality parameters exceed these values, a proportion of the water in the system should be replaced in order to improve water quality. Water exchanges should be continued until optimum water quality is attained.

Ammonia, nitrite, nitrate and pH can be easily tested using colourimetric analyses which are available in test kits designed for marine aquarium use. It is worth investing in a good quality test kit which includes colourimetric analyses of all these variables, and for which additional reagents can be purchased once the original supply is exhausted.

**Table 2** Recommended levels of water quality parameters for marine recirculating systems.

	Optimum	Minimum	Maximum
Ammonia	< 0.2 ppm	-	1 ppm
Nitrite	< 0.5 ppm	-	5 ppm
Nitrate	< 5 ppm	-	20 ppm
pH	8.0	7.0	9.0

A proportion of the water in the system should be changed regularly to replace some of the trace elements which may be removed by filtration. A water change of about 5-10% each week is recommended. Water changes should be timed to coincide with the peak in ammonia levels which occurs after fish are added to the system.

### *Shock Loading*

The importance of 'shock loading' is often overlooked by managers of holding facilities. The term 'shock loading' refers to the affect on a system suddenly having its biomass increased by a substantial amount, as often happens when a large load of fish is added to the system. The only way a filter can assimilate the increased amounts of ammonia excreted by the fish is to enlarge its population of nitrifying bacteria. As these bacteria grow relatively slowly, this may take anything up to 2-3 weeks, depending mainly on temperature. To avoid this problem, fish should be added slowly (i.e.10-20% every few days) and attempts should be made to operate the system at a relatively constant load. 'Fluidised bed' biofilters are reported to handle shock loading better than other biofilter designs.

One method of preparing for shock loading in a recirculating system is to increase levels of ammonia by adding ammonium chloride, to simulate the excretion of ammonia by fish. The amount of ammonium chloride to be added will vary between facilities; it should be enough to give a similar response to the addition of whatever biomass of fish is to be introduced to the system. The ammonia concentration should be increased gradually, and should be monitored using a test kit. Ammonium chloride should not be added to tanks that already contain fish. This may require the construction of separate systems or subsystems for the fish holding facility if shock loading is likely to be a routine occurrence. The addition of ammonium chloride should cease 1-2 days prior to the addition of fish, to allow the biofilter to remove the ammonia in the water.

Some of the commercial broths mentioned earlier may ease the effect of shock loading, but the user should monitor the levels of nitrogenous compounds, especially ammonia, during the use of these additives. A large water reservoir and low stocking densities will also reduce the effects of shock loading. As noted earlier, water changes carried out soon after the introduction of additional fish will also reduce peak ammonia levels and alleviate shock loading effects.

### *Mechanical Filters*

The main form of mechanical filtration necessary in a closed-circuit holding system is a prefilter. The prefilter removes particulate matter from the water before it enters the biofilter, thus preventing clogging of the biofilter. The prefilter can be as simple as a sheet of air-conditioning insulation material over the spreader plate of the biofilter to trap particulate matter. The prefilter should be cleaned regularly to maintain adequate flow through the spreader plate.

Additional mechanical filtration is rarely necessary in closed-circuit holding systems. However, if the biofilter clogs with particulate matter regularly, a sand filter should be incorporated into the system upstream of the biofilter. Sand filters designed for use with swimming pools are generally suitable for live fish holding systems. To keep sand filters working efficiently, they should be backwashed regularly.

Mechanical filtration, as well as increased biological filtration, is important if the fish are to be fed while in the holding system. Generally, it isn't necessary to feed the fish, even if they are held for several weeks. If the fish are fed, they should be 'purged' prior to transport.

### *Foam fractionation*

Foam fractionation, or protein skimming, has been an important aspect of marine aquarium management for some years and has only recently spread to commercial holding facilities. Large molecules, such as proteins, and small particles, such as lipid droplets, are not efficiently removed by biofilters and are too small for mechanical filters. Protein is often seen accumulating on the water

Ammonia, nitrite and nitrate can be expressed in two forms, either the concentration of the compound or the concentration of the compound as its nitrogen equivalent. Different test kits express the results in different forms.

To convert one form to the other, use the following conversion factors:

1 mg/l NH<sub>3</sub>-N = 1.22 mg/l NH<sub>3</sub>

1 mg/l NO<sub>2</sub>-N = 3.28 mg/l NO<sub>2</sub>

1 mg/l NO<sub>3</sub>-N = 4.43 mg/l NO<sub>3</sub>



surface as froth, and often a residue will collect on the sides of the holding tanks. This results in deterioration of water quality, but these substances can be removed by foam fractionation. The operating principle of foam fractionators is that when fine air bubbles are forced through a body of water they will extract dissolved organic materials which collect on the surface as foam. A foam fractionation system can be easily constructed from large diameter PVC pipe. Water is pumped in at the top of the column and flows out the bottom (Figure 25). Air is bubbled into the bottom of the column, so that it flows in the opposite direction to the water (counter current design). It is important to use an airstone which produces very fine air bubbles to construct an efficient foam fractionator. The foam accumulates in a collecting cup fitted to the top of the pipe (Figure 25).

There is some evidence that foam fractionation will remove various micronutrients and trace elements from sea water. This is unlikely to affect fish held for relatively short periods (several weeks), but regular partial water changes (5-10% per week) will serve to replace any micronutrients removed by foam fractionation.

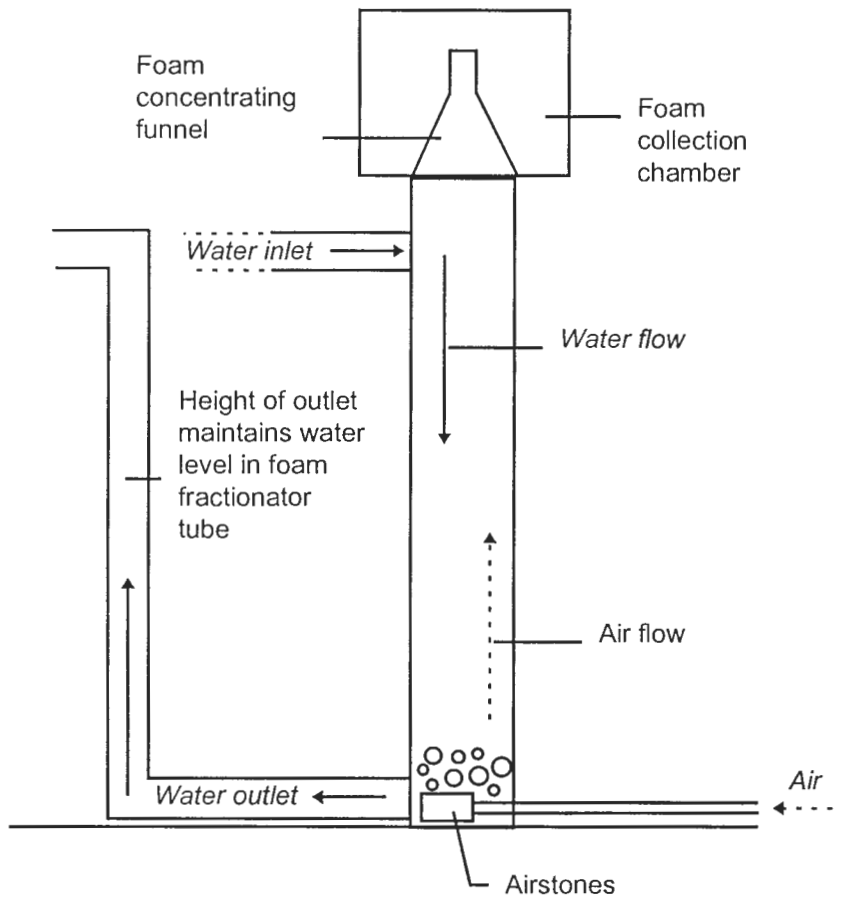

**Figure 25** Diagram of counter-current foam fractionator. Arrows indicate the direction of water and air flow. If ozone is applied, it should be introduced to the air supply via the airstone(s).

### *Ozone and Ultraviolet Light*

Ozone (O<sub>3</sub>) is a particularly reactive molecule that enables organics to be oxidised, by increasing the oxidation / reduction potential. Direct contact with ozone may kill fish, so it is applied to the foam fractionator in the counter-current aeration supply to prevent it coming in direct contact with fish in the holding tanks. Ozone should be used with care in systems holding invertebrates, because it may cause some molluscs to spawn.

Ultraviolet filters kill bacteria and other pathogens by the application of ultraviolet light. They may reduce the incidence of disease in live fish holding systems by reducing the bacterial flora in the system. However, ultraviolet filters are expensive to purchase and are also expensive to run, since the water tubes must be kept clean to allow the light to penetrate and the light tubes must be regularly replaced to maintain efficiency.

While ozone and ultraviolet filtration systems may improve fish health by reducing the bacterial flora, both are relatively expensive and the cost-benefits of such systems are dubious. For this reason, they are rarely used in live fish holding systems.

### *Conclusion*

Recirculating systems are ideal for holding live fish prior to packing and dispatch. Successful operation of a recirculating system requires an understanding of the processes involved in biological filtration and a commitment to manage the system to provide optimal water quality at all times. The most difficult aspect of maintaining a recirculating system for live fish is coping with 'shock loading'. Different filter designs will respond to shock loading in different ways, and it is up to the manager of the live fish facility to become familiar with the system and to regularly monitor its performance. The overall objective of fish holding facilities should be not only to keep fish alive, but also to minimise stress. Care taken during the holding phase will pay off by improving survival during transport and providing a better quality product to the consumer.

### *Reference*

de Guingand, P., Rimmer, M., Brouwer, R. and Meikle, G. (1995). Live fish 'on hold' - system design is the key to success. *Australian Fisheries* 54(2), 14-18.

### *Further Reading*

A useful reference on the design and operation of recirculating systems is:

Hart, P. and O'Sullivan, D. (eds.) (1993). 'Recirculation Systems: Design, Construction and Management'. Key Centre for Aquaculture Workshop Series, University of Tasmania. 127 pp. Available from 'Dosaqua', P.O. Box 243, Mowbray, Tas. 7248.

# SECTION 2

## ***PACKAGING AND LIVE TRANSPORT***



### ***CONTENTS***

#### **Packaging systems for air transport of live fish**

P.F. de Guingand, G.M. Meikle and M.A. Rimmer

#### **Water quality in live fish transport**

M.A. Rimmer, P.F. de Guingand and G.M. Meikle

#### **Physiological responses of barramundi *Lates calcarifer* to water quality deterioration during simulated live transport: acidosis, red-cell swelling, and levels of ions and ammonia in the plasma**

B.D. Paterson, M.A. Rimmer, G.M. Meikle and G.L. Semmens

#### **The use of temperature reduction as an aid to the transportation of live finfish**

M.A. Rimmer, P.F. de Guingand and G.M. Meikle

#### **Removal of carbon dioxide in live fish transport**

M.A. Rimmer, J. Pennefather, G.M. Meikle and P.F. de Guingand

#### **Road transport of live fish**

M.A. Rimmer

# Packaging systems for air transport of live fish

**P.F. de Guingand<sup>1</sup>, G.M. Meikle<sup>2</sup> and M.A. Rimmer<sup>2</sup>**

1 Southern Ocean Products, 'The Gulch', Bicheno, Tasmania 7215.

2 Queensland Department of Primary Industries, Northern Fisheries Centre, PO Box 5396, Cairns, Queensland 4870.

## **Abstract**

There are basically 3 methods that are commonly used in Australia for transporting live finfish by air:

1. the polystyrene seafood box;
2. the 'pickle barrel' system;
3. the 'big box' system.

Details of these various packaging techniques are provided in this section. 'Purging' fish prior to packing to alleviate water quality degradation during transport is necessary for only 2-3 days.

## **'Purging'**

Live fish are commonly held and starved for a period of time prior to packing and transport, a procedure known in industry circles as 'purging'. The objectives of purging are:

1. reduce water quality degradation in the transport medium due to bacterial decomposition of faecal matter; and
2. reduce ammonia accumulation in the transport medium resulting from ammonia excretion.

Faecal matter in the transport medium provides a substrate for bacterial decomposition, which reduces dissolved oxygen levels and contributes to ammonia and carbon dioxide accumulation (Amend *et al.* 1982). This problem can be substantially alleviated by allowing the fish to void their gut contents prior to transport. Gut contents are usually voided relatively rapidly, i.e. within 1-2 days. The status of the fish can be assessed visually, by checking for faecal material several times per day and regularly cleaning the holding tanks. Ammonia excretion peaks relatively soon after feeding, and decreases rapidly, for example for barramundi ammonia levels peak around 3 hours after feeding, and decrease to pre-feeding levels about 12 hours after feeding (Almendras 1994). Consequently, fish need be purged only for 1-2 days to reduce ammonia levels. Additional purging will not further lower ammonia excretion rates, since ammonia continues to be produced by the metabolism of body protein in the absence of food (Almendras 1994). Consequently, the easiest and best strategy for purging fish prior to live transport is to ensure that the gut contents have been completely voided before packing the fish, a process that usually takes only 2-3 days.

## **Packaging**

### ***Polystyrene seafood box***

At the commencement of this project, the most commonly used method for transporting finfish by air was the standard seafood expanded polystyrene box with plastic bag and foam liners. Two foam liners and 2 plastic bags (minimum thickness 100µm) are placed inside a

15-kg capacity expanded polystyrene box. All boxes used for seafood transport must be approved for this use by the airlines, and approved boxes are marked with a fish symbol. Once the packaging material is in place, a measured volume of water is placed in the plastic bags (Figure 1). The exact amount of water to be used depends on the weight of fish to be packed and the desired water:fish ratio: for example, if fish with an average weight of 1-kg are to be packed, and the desired water:fish ratio is 2:1, then 5 fish can be packed with 10-kg (i.e. 10-litres) of water. The water to be added to the bags should be clean and filtered and should be adjusted to the desired temperature for transport (normally, this involves chilling the transport water). Air is removed by closing the neck of the inner plastic bag, then pushing down the bags so that the bags contact the surface of the water and the air is displaced. The nozzle of an oxygen hose is placed in the neck of the inner bag, and the bag filled with oxygen (Figure 2). Adding the right amount of oxygen to the bags requires practice: enough oxygen is added to the bag so that the lid of the polystyrene box can be easily fitted to the box, and the bag should be as full as possible of oxygen. Once the bag has been filled with oxygen, the neck of the inner bag is 'goose necked', i.e. it is turned around multiple times to seal the bag, then turned over on itself in a  $\cap$  shape. The inner bag is then sealed using strong rubber bands or sheep marking rings (elastators) (Figure 2). The outer bag is goose-necked and sealed similarly and the lid is placed on the box (Figure 3). The lid of the box is taped in place according to the regulations of the relevant airline, usually once around the seal between box and lid, twice along the short axis of the box, and once around the long axis (Figure 3).

A similar packaging system has been used for many years by the aquarium fish industry. However, as most ornamental fish are relatively small, they are generally transported individually in small plastic bags. A piece of folded newspaper is placed between the 2 plastic bags to reduce the chance of fin spines puncturing both bags and causing water leakage. Many small plastic bags may be shipped in each polystyrene box.

Although usually effective, the polystyrene box packaging suffers from a number of problems:

- Large fish often puncture the plastic bags with their fin spines, allowing water to leak out into the box. Although the foam pads in the bottom of the box absorb some water, these are often insufficient if severe leakage occurs.
- Puncturing of the bags allows the bags to collapse inside the box. Oxygen is forced out of the bags, and the fish are effectively in a closed bag with no oxygen. Consequently, mortality rates may be very high.
- Heavy handling of the boxes often causes damage and severe leakage of the contents.



**Figure 1** (Above) Fish are removed from the holding tank using a net constructed with soft, knotless mesh. (Below) Water and fish are placed in the double plastic bags inside the transport box.



**Figure 2** (Above) Air is removed from the inner bag, and replaced with oxygen. (Below) Both plastic bags are 'goose-necked' and sealed with rubber bands or elastrator rings.



**Figure 3** (Above) The inner bag is inflated with oxygen and inner and outer bags are separately sealed. (Below) The lid is placed on the box and the box is taped to airline regulations, and labelled.



### ***Pickle barrels***

Another live fish transport system in use in southern Australia is the 'pickle barrel' system. A number of large (60-litre) screw-top plastic containers are used on smaller commercial aircraft, usually twin engine turboprop planes. Each container is half filled with water, then fish are added to make up the volume (giving a water:fish ratio of about 1:1). The screw-top lid prevents water spillage, and oxygen is supplied from a bottled oxygen system within the fuselage. This system has been primarily used to transport live fish from Tasmania to Melbourne and Sydney. There have been several reported problems with this system, mostly associated with aircraft reliability and occasional high mortality of fish.

### ***AV packaging systems***

This new live fish transport system consists of a new larger box, usually large enough to take up most of the space in an AV (LD3) airfreight container. An oxygen cylinder is either strapped alongside the box, or on top of, or inside, the lid. Boxes are made from a range of materials including insulated plastics, fibreglass, and aluminium. Although the modified Xactics™ / Dyno™ seafood bins are one of the most popular of the new live fish transport systems, in general any new packaging will be assessed by aircraft load management provided that it meets certain criteria. For example the box should not spill any water if tipped on a 45° angle, and if oxygen cylinders are used then a dangerous goods certificate must be filled out by the shipper.

It should be noted that (at the time of writing) packaging systems using compressed oxygen have been banned for use into Hong Kong.

### ***Unpacking***

The process of removing transported fish and placing them in holding tanks at their destination is relatively straightforward, but must be done carefully to minimise fish mortality. Water quality in the transport bags will be dramatically different to that of the holding tank, and the transfer of fish from one to the other should be done slowly in order to prevent rapid changes in water quality.

Initially, the bags should be removed from the boxes and floated in the holding tank (Figure 4). This will allow the water temperature in the bag to equilibrate with that of the holding tank. The bags should be opened and aeration supplied to each bag to increase dissolved oxygen levels. Water from the holding tank should be added slowly to each bag to allow water quality to equilibrate slowly, until at least an equivalent volume of water to that already in the bag has been added to each bag. The duration of this acclimation process varies according to water conditions in the transport bags and in the holding tank, and with different fish species. Generally, acclimation should take from 30 minutes to 2 hours before the fish are released into the holding tank.



**Figure 4** (Above) Upon receipt, the plastic bags are removed from the transport boxes and floated in the destination holding tanks to facilitate temperature equilibrium between the tank and the bags. (Below) Barramundi transported from Cairns to Hong Kong and released in the destination holding tanks.

## **References**

Almendras, J.M.E. (1994). Ammonia excretion rates of the sea bass, *Lates calcarifer*, in fresh and sea water. The Israeli Journal of Aquaculture - Bamidgeh 46, 76-82.

Amend, D.F., Croy, T.R., Goven, B.A., Johnson, K.A. and McCarthy, D.H. (1982). Transportation of fish in closed systems: methods to control ammonia, carbon dioxide, pH, and bacterial growth. Transactions of the American Fisheries Society 111, 603-611.

# Water quality in live fish transport

M.A. Rimmer<sup>1</sup>, P.F. de Guingand<sup>2</sup> and G.M. Meikle<sup>1</sup>

- 1 Queensland Department of Primary Industries, Northern Fisheries Centre, PO Box 5396, Cairns, Queensland 4870.
- 2 Southern Ocean Products, 'The Gulch', Bicheno, Tasmania 7215.

## Abstract

The major water quality effects experienced by fish during transport are: low dissolved oxygen levels due to oxygen consumption by respiration; accumulation of carbon dioxide from respiration; depression of pH caused by carbon dioxide accumulation; and increased ammonia levels resulting from ammonia excretion. A time-series experiment showed that most water quality degradation occurs rapidly, within the first hour after packing. An experiment to test the effects of containment on fish demonstrated that containment *per se* had no effect on survival, indicating that mortality can be attributed to the changes in water quality that occur during fish transport in closed systems. A manipulative experiment testing various water quality variables indicated that carbon dioxide accumulation is the major limiting factor affecting survival of fish during live transport. High carbon dioxide levels cause hypercapnia, and narcotise and eventually kill the fish.

## Introduction

Transport of live fish in closed systems, as is generally used for air transport, results in significant degradation of water quality throughout the transport period. Excretory products, mucus and regurgitated food degrade water quality and stress the fish (McFarland and Norris 1958, Piper *et al.* 1982, Berka 1986). Changes in various water quality parameters are complex and inter-related, and reducing the water:fish volume aggravates many of these water quality problems. Respiration causes decreased levels of dissolved oxygen and increased levels of carbon dioxide in the transport medium. Despite the addition of oxygen to the gas space within the plastic bags, the lack of agitation during typical air freight operations exacerbates this problem by reducing dissolution of gases across the water-gas interface. Excretion increases the level of ammonia in the transport medium. Increasing carbon dioxide levels depress pH which effectively increases the toxicity of carbon dioxide, but decreases the toxicity of ammonia.

Water quality in closed fish transport systems is a function of loading density and the length of transport time. Respiration by the fish causes depletion of oxygen and production of the toxic metabolite carbon dioxide. Ammonia is excreted via the gills and ammonia also accumulates in the transport water. The increase in carbon dioxide causes water pH to decrease. Low pH increases the proportion of the toxic form of carbon dioxide (CO<sub>2</sub>), but decreases the proportion of the toxic form of ammonia (NH<sub>3</sub>) (McFarland and Norris 1958, Amend *et al.* 1982).

## Oxygen

Maintenance of adequate dissolved oxygen levels is critical to the successful transport of fish (Piper *et al.* 1982, Berka 1986). The ability of fish to use oxygen depends not only on dissolved oxygen levels in the transport medium, but also on the stress status of the fish, water temperature, pH, and concentrations of carbon dioxide and ammonia (Piper *et al.* 1982, Berka 1986). The main factors affecting oxygen consumption by fish during transport are fish weight and water temperature (Berka 1986). For example, if water temperature increases by 10°C, oxygen consumption is about doubled (Berka 1986). For every 0.5°C increase in temperature, the fish load should be reduced by about 5.6% (Piper *et al.* 1982, Berka 1986).

Saturation is a measure of the maximum amount of oxygen that water will hold under certain conditions. Oxygen saturation is a function of temperature, salinity and pressure (altitude) (Boyd 1990). Oxygen solubility decreases with increasing temperature, increasing salinity (Figure 5) and increasing altitude. (Oxygen saturation values for water at various combinations of temperature and salinity are listed in Appendix 3).

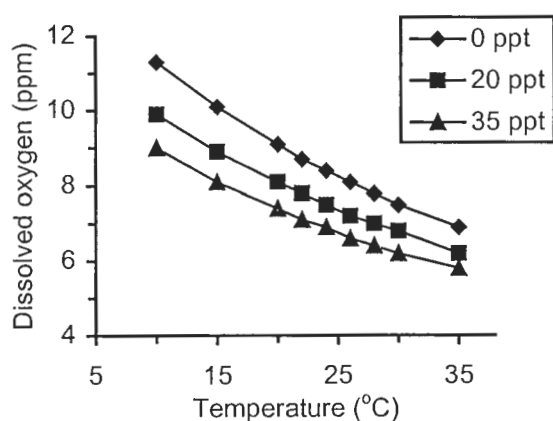

**Figure 5** Saturation values of dissolved oxygen in water at 3 different salinities (0, 20 and 35 ppt) and a range of temperatures (Boyd 1990).

Low oxygen levels result in severe stress due to hypoxia and a subsequent build-up of blood lactic acid and may contribute to a delayed fish mortality (Piper *et al.* 1982). Adequate oxygen levels suppress harmful effects of ammonia and carbon dioxide (Piper *et al.* 1982). Generally, increased levels of carbon dioxide require higher dissolved oxygen levels (Piper *et al.* 1982).

Oxygen consumption is greatest during handling and packing, when oxygen consumption may increase three to five times compared with normal levels (Piper *et al.* 1982, Berka 1986). Even after packing, oxygen consumption rates may remain high. Froese (1988) recorded oxygen consumption rates ranging from 0.21 to 5.46 mg/g/h in ornamental fishes shipped in plastic bags from Singapore to Europe, and noted that this oxygen consumption was equivalent to approximately three times higher than the routine metabolic rate.

Oxygen levels are maximised by replacing air (20% O<sub>2</sub>) with pure oxygen (100% O<sub>2</sub>) within the packaging. Additional oxygen can be added by chemical means. Hydrogen peroxide has been used to generate oxygen as a byproduct of its dissociation:  $2\text{H}_2\text{O}_2 \rightarrow 2\text{H}_2\text{O} + \text{O}_2$  (Innes-Taylor and Ross 1988). Hydrogen peroxide can either be added to the transport water directly (although high concentrations are toxic) or placed within the packaging in a separate container (Innes-Taylor and Ross 1988). The rate of oxygen production from hydrogen peroxide can be increased by adding a catalyst such as activated charcoal or animal tissue (Innes-Taylor & Ross 1988).

A variety of chemical packs that produce oxygen for live fish transport applications are now available. Some are immersed directly in the transport water, while others are packed outside the inner bags and release oxygen through a fine airstone inside the bags.

### ***Temperature***

Generally, fish are unable to regulate their own body temperature, so the temperature of the surrounding water directly affects their metabolic rate. The metabolic rate of fish is higher at higher temperatures, and thus as temperature increases they will use more oxygen, and produce more carbon dioxide and ammonia than at lower temperatures. Temperature reduction is commonly used in fish transport applications to reduce the metabolic rate of the fish, in order to reduce oxygen consumption and the production of ammonia and carbon dioxide (Piper *et al.* 1982, Berka 1986).

### ***Carbon dioxide***

Carbon dioxide is produced as a product of fish and bacterial respiration and accumulates in closed transportation systems. Generally, for each millilitre of oxygen a fish consumes, it produces about 0.9 millilitres of carbon dioxide (Piper *et al.* 1982, Berka 1986). Carbon dioxide is found in several forms: CO<sub>2</sub>, HCO<sub>3</sub><sup>-</sup> and CO<sub>3</sub><sup>2-</sup>, the relative proportions of which depend primarily on the pH of the water (Figure 6). Of these, only CO<sub>2</sub> is directly toxic to fish. Elevated carbon dioxide levels are detrimental to fish and are widely considered to be an important limiting factor in fish transportation (Piper *et al.* 1982).

Carbon dioxide lowers pH which reduces the proportion of unionised ammonia in the water, but also reduces the oxygen-carrying capacity of fish blood, even when dissolved oxygen levels are high (McFarland and Norris 1958, McCraren and Millard 1978, Piper *et al.* 1982, Berka 1986). There is little information on lethal CO<sub>2</sub> concentrations for fishes. Salmonids appear to tolerate carbon dioxide levels up to 15 ppm when other water quality parameters are adequate, but become distressed when carbon dioxide levels approach 25 ppm (Piper *et al.* 1982). Evidently, other fishes are capable of withstanding much higher CO<sub>2</sub> levels: Froese (1985) recorded carbon dioxide levels averaging 170 ppm in plastic bags used to transport ornamental fishes from Singapore to Europe.

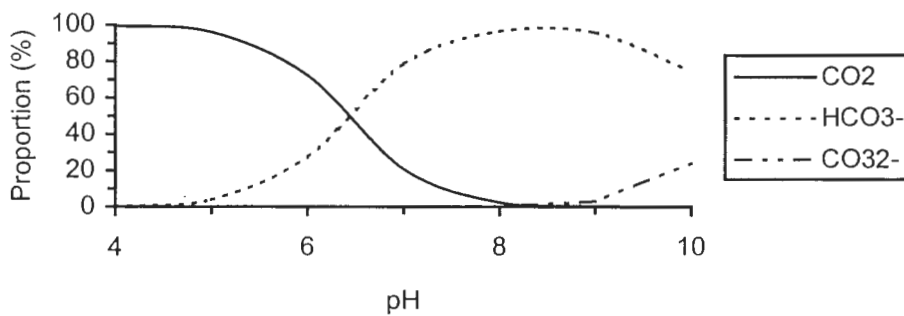

**Figure 6** Proportions of CO<sub>2</sub>, HCO<sub>3</sub><sup>-</sup> and CO<sub>3</sub><sup>2-</sup> in water at different pH values.

### *Ammonia*

Ammonia is the main nitrogenous compound excreted by fish and will accumulate during transport (Piper *et al.* 1982). Ammonia has two forms, unionised ammonia (NH<sub>3</sub>) which is toxic to fish and ionised ammonia (NH<sub>4</sub><sup>+</sup>) which is effectively non-toxic. The relative proportions of each form depend primarily on water temperature and pH (Boyd 1990). The higher the pH and temperature, the more ammonia will be present in the toxic NH<sub>3</sub> form (Figure 7). Most test kits measure total ammonia, ie. the combined total of NH<sub>3</sub> and NH<sub>4</sub><sup>+</sup>. The proportion of NH<sub>3</sub> must then be derived from published tables of ammonia dissociation (Appendix 4) to determine the concentration of the toxic form in the water.

Total ammonia concentrations can reach 10 ppm or higher in fish distribution tanks (Piper *et al.* 1982). Exposure to 11-12 ppm total ammonia (equivalent to 0.13-0.14 ppm unionised ammonia) for 6 hours or greater adversely affects salmonids and can reduce fish stamina (Piper *et al.* 1982).

The main factors affecting ammonia excretion in fish are temperature and time from last feeding. For example, trout held in water at 1°C excrete 66% less ammonia than those held in 11°C water, and fish starved for 63 hours before shipment produce half as much ammonia as do recently fed fish (Piper *et al.* 1982). Reduction in ammonia production in warmwater fishes may be much more rapid. Almendras (1994) found that ammonia excretion by barramundi (*Lates calcarifer*) peaked about 3 hours after feeding, and had returned to pre-feeding levels within 12 hours. Longer term starvation (up to 24 days) had no effect on ammonia excretion rates in barramundi (Almendras 1994).

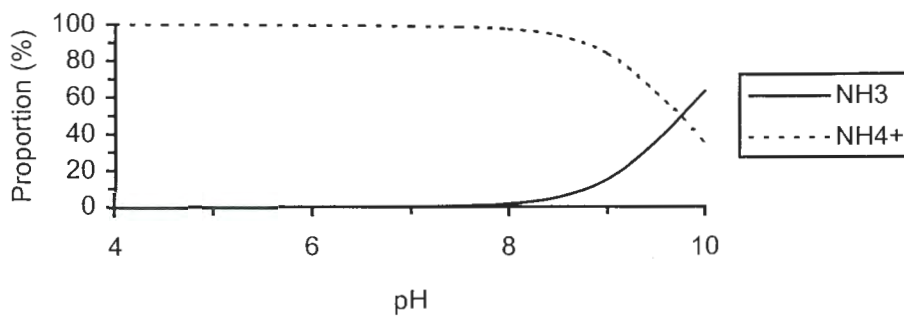

**Figure 7** Proportion of NH<sub>3</sub> and NH<sub>4</sub><sup>+</sup> at different pH values.

### ***pH***

The pH of salt water is usually about 8.0 and the pH of freshwater is about 7.0. Because of the large buffering capacity of salt water, pH in salt or brackish water generally varies less than in freshwater. pH may drop dramatically in fish transport tanks, if carbon dioxide is allowed to accumulate in the water. Low pH causes a range of physiological problems in fish, but primarily affects the fishes' ability to utilise oxygen for respiration. Thus at low pH and high carbon dioxide concentrations, fish may suffer severe respiratory stress even though dissolved oxygen levels are high. Declining pH in fish transport applications is the direct result of carbon dioxide accumulation. Froese (1985) recorded pH values of 5.5 to 6.5 in water used to ship ornamental fishes from Singapore to Europe.

pH can be controlled using pH buffers to reduce the rate of pH change during transport. The most widely used pH buffer in fish transport applications is trishydroxymethylaminomethane ('tris buffer') which has been used on a range of fish species with no deleterious effects (McFarland and Norris 1958, Piper *et al.* 1982, Burton 1988). Levels of 1.3-2.6 g/l are recommended for routine transportation of fish (Piper *et al.* 1982).

### ***Water quality in live fish transport***

The experiments described in this section were designed to investigate the role of various water quality parameters in the survival of transported fish. Two types of experiments were undertaken to assess the major factors that affect fish in transport: simulated transport trials and manipulative experiments. The first type of experiment, the simulated transport trial, was undertaken using conditions similar to those experienced by fish during air transport, i.e. with fish in a 'closed' transport system. The manipulative experiments attempted to determine whether individual variables, or combinations of variables, limit the survival of fish during transport. To verify that the results of these laboratory experiments were relevant to actual transport conditions, a number of real transport trials were undertaken using standard packaging techniques.



## **Materials and Methods**

At Northern Fisheries Centre (NFC), juvenile barramundi (*Lates calcarifer*) 20 - 30 cm total length (TL) and about 0.5 kg weight were obtained from a commercial barramundi farm and held at NFC for one month prior to the commencement of the experiments. In all experiments the fish were handled with a soft knotless mesh net to prevent physically damaging the fish. At Southern Ocean Products (SOP), banded morwong (*Cheilodactylus spectabilis*) were obtained from commercial fishers and held for several weeks prior to use in these experiments. Food was withheld from the fish for a period of 4 days prior to each experiment so that they had empty guts when the experiment was undertaken.

Standard seafood packaging techniques were used in these experiments. Two 100µm thick plastic bags, one inside the other, were placed in an expanded polystyrene seafood transport box (c. 40 cm × 60 cm × 30 cm, nominal capacity 15 kg). Water was placed in the inner bag, temperature and dissolved oxygen were recorded and a water sample was taken to measure the initial water quality (pH, CO<sub>2</sub>, NH<sub>3</sub>-N). The fish were then placed in the inner bag. Air was expelled from the inner bag, and the bag refilled with oxygen. The bag was sealed by twisting the bag closed and sealing it with a rubber band or an elastrator ring. The outer bag was sealed in a similar fashion, then the lid was taped in place. During each experiment the boxes were left in place, with no external agitation.

At the termination of each experiment, the boxes and bags were opened, and the time, water temperature and dissolved oxygen levels were measured and recorded, and a further water quality sample taken. The number of dead fish was recorded. An airstone was then placed in the transport water with the fish to aerate the water and remove accumulated CO<sub>2</sub>. A volume of clean salt water equal to the initial volume in the box was added to each box, to acclimate the fish back to holding system conditions. The fish were left in the boxes for 30 minutes, after which they were removed from the box, weighed and returned to the holding tanks. Fish from each treatment were kept in different tanks for 24 hours after each trial so that any post-trial mortalities could be recorded.

Temperature and dissolved oxygen were analysed using a Yellow Springs Instruments Model 55 or Model 58 dissolved oxygen meter. Carbon dioxide was measured using the methods outlined in Boyd (1979) (barramundi), or using a La Motte portable titration kit (phenolphthalein indicator) (banded morwong). Ammonia-nitrogen was measured according to the indophenol method (Boyd 1979) using a Bausch and Lomb Spectronic 21 spectrophotometer (barramundi) or using a Lovibond colorimetric system (banded morwong). pH was measured with a Mettler Delta 350 pH meter and Mettler Ionode pH probe (barramundi), or using a Hanna HI9023 portable pH meter (banded morwong).

### **Experiment 1 - Temporal changes in water quality**

This experiment examined changes in water quality over time. Barramundi were packed into standard seafood transport boxes, with a small diameter hose leading from each box. Water quality samples were removed at hourly intervals using a syringe to withdraw water via the hose. The water samples were analysed for dissolved oxygen, carbon dioxide and ammonia-

nitrogen using the methods described above. Temperature in the boxes was recorded using dataloggers.

### *Experiment 2 - Effects of containment*

This experiment was designed to determine if the actual packing and confinement in transport boxes is in itself detrimental to the survival of transported fish. The various treatments were:

1. 'Standard Pack': This treatment is the standard packaging technique used commercially and described in the previous section. As described above, this is a fully closed system and oxygen is used up as the trial progresses, and metabolic processes result in accumulation of carbon dioxide and ammonia, and depression of pH.
2. 'Aerated': This treatment was similar to the 'standard pack', but aeration was added to the bag and the inner bag was allowed to vent, thus forming an open system. Aeration provides additional oxygen to compensate for that used in respiration, and removes carbon dioxide.
3. 'Oxygenated': Oxygen was added to the bag via an airstone to maintain high levels of dissolved oxygen.
4. 'Flow through': In this treatment, aeration was provided, and each box was set up with a water inlet and an overflow type outlet, allowing a constant exchange of water during the trial. This treatment allowed high levels of oxygen, and low levels of carbon dioxide and ammonia, so adverse water quality is unlikely to affect the fish. This treatment was designed to test what effect packaging and containment had on fish survival.

Three replicates of each treatment were used. This experiment was run for approximately 18 hours with water:fish ratios ranging from 2.2:1 to 3.1:1.

### *Experiment 3 - Adverse water quality*

In this experiment, the role of different water quality variables was further examined to determine which variables are most likely to be limiting factors in live fish transport. In addition to the 'standard pack', two more treatments were used:

1. Ammonia added. Based on data obtained from previous trials, the excretion of ammonia for barramundi is approximately 0.7 mg NH<sub>3</sub>-N /litre /hour for a box of fish. In this treatment the fish were packed as for a standard pack but NH<sub>4</sub>Cl equivalent to that obtained after 20 hours of transport was added to each replicate in this treatment. An additional 53.4 mg NH<sub>4</sub>Cl /litre transport water was added. Thus, after an additional 18-20 hours of simulated transport, the total ammonia levels in the transport water should be approximately double those usually obtained.
2. Carbon dioxide added. Carbon dioxide was added to the transport water by bubbling carbon dioxide from a gas cylinder through the water through an airstone for a set period of time. As for the 'ammonia added' treatment, the intention was to provide initial conditions similar to those that would normally be experienced at the end of the trial. After adding carbon dioxide to the transport water, water samples were taken to measure the initial concentration of CO<sub>2</sub> and then the fish added.

## Results

### Experiment 1 - Temporal changes in water quality

Water quality results from this experiment are shown in Figure 8. It is notable that most water quality deterioration occurred within the first 1-2 hours after packing. Following this initial period of rapid change, changes in water quality occurred at a much slower rate for the rest of the experiment. Dissolved oxygen levels at packing were 7.2 mg/l, but dissolved oxygen dropped rapidly to only 3.5 mg/l within 1.2 hours after packing. Dissolved oxygen levels then stabilised at around 3.0-3.5 mg/l for the rest of the experiment. Carbon dioxide also built up rapidly, from 13 to 38 mg/l within 1.2 hours, and continued to accumulate at a much lower rate throughout the experiment (Figure 8). pH dropped rapidly from an initial value of 8.1 to 6.8 after 1.2 hours, and continued to decline slowly, reaching 6.1 after 13 hours. In contrast to these variables, ammonia accumulated at a relatively constant rate throughout the experiment (Figure 8).

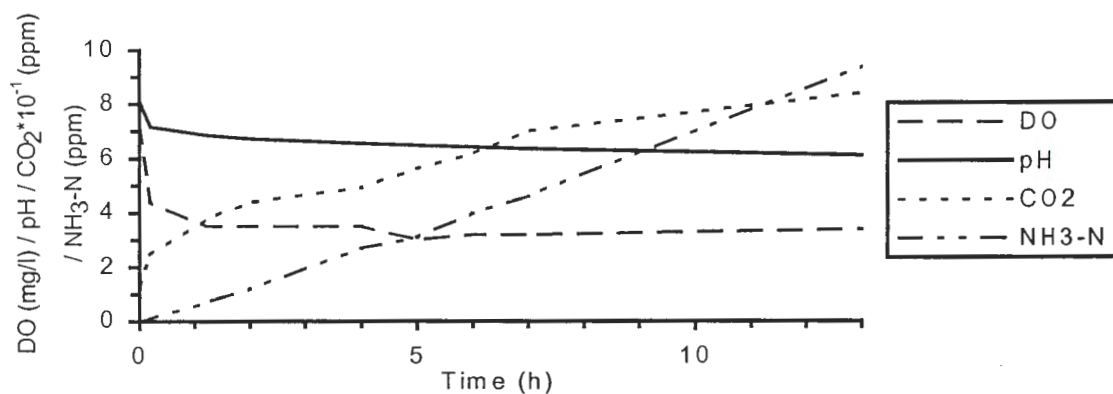

**Figure 8** Changes in dissolved oxygen (D.O.), pH, carbon dioxide (CO<sub>2</sub>) and ammonia-nitrogen (NH<sub>3</sub>-N) during a simulated transport trial undertaken with barramundi at an average water:fish ratio of 2.6:1, and with 100% survival.

### *Experiment 2 - Effects of containment*

Initial and final conditions for all treatments are shown in Table 1. Mortality was highest in the standard packaging treatment (61%), and considerably lower in all the other treatments (0-17%). No fish died in the flow-through treatment. Both carbon dioxide and ammonia were highest in the standard packaging treatment, and lowest in the flow-through treatment. pH remained relatively constant in the flow-through treatment, and decreased substantially in the other three treatments.

**Table 1** Initial and final values for water quality parameters and mortality for barramundi subjected to 4 treatments for 18 hours in simulated transport conditions. All values are means of 3 replicates.

Treatment	Mortality	Temp. (°C)	D.O. (mg/l)	pH	CO <sub>2</sub> (mg/l)	NH <sub>3</sub> (ppm)
Initial		25.7	6.4	8.3	0	0.7
Standard pack	61%	25.3	2.7	5.5	137	14.7
Aerated	17%	25.1	1.7	6.6	27	10.7
Oxygenated	7%	26.1	2.6	6.1	102	23.8
Flow-through	0%	25.8	4.1	8.0	11	0

**Table 2** Initial and final values for water quality parameters and mortality for banded morwong subjected to 3 treatments for 18 hours in simulated transport conditions. All values are means of 3 replicates.

Treatment	Mortality	D.O. (mg/l)	pH	CO <sub>2</sub> (mg/L)	NH <sub>3</sub> (mg/l)
Standard pack	69%	5.5	5.8	99	4.3
Aerated	0%	4.4	6.9	11	2.2
Flow-through	0%	4.4	7.1	5	0.8

### *Experiment 3 - Adverse water quality*

Water quality and mortality data for this experiment are listed in Table 3. The highest mortality (73%) occurred in the treatment that had carbon dioxide added at the beginning of the experiment. This resulted in a higher than planned carbon dioxide concentration of over 200 mg/l, which had dropped to about 140 mg/l by the end of the trial. Ammonia levels at the end of the experiment were comparable with those for the standard pack. Dissolved oxygen levels remained high in these treatment, and were around 7 mg/l at the end of the experiment.

Mortality was also high in the ammonia treatment (40%). As intended, ammonia levels at the beginning of the experiment were comparable with those that would normally be experienced after about 20 hours of transport. Ammonia levels continued to rise after packing, and were over 20 mg/l by the end of the experiment. As in the standard packaging treatment, dissolved oxygen levels were low at the end of the experiment (*c.* 2.5 mg/l).

As for the previous experiment, the flow-through treatment had no mortality, and maintained optimal water quality conditions for the duration of the experiment.

**Table 3** Initial and final conditions for barramundi subjected to adverse water quality conditions in simulated transport conditions. All values are means of three replicates.

Treatment	Initial / Final	Duration (hh:mm)	Mortality	D.O. (mg/l)	Temp. (°C)	pH	CO <sub>2</sub> (mg/l)	NH <sub>3</sub> (ppm)
Standard pack	I			7.1	21.7	7.8	11	0
	F	20:50	13%	2.2	21.9	5.5	113	10.3
Ammonia	I			7.1	21.7	7.7	11	12.6
	F	19:58	40%	2.5	21.6	5.4	118	21.6
Carbon dioxide	I			5.9	21.7	5.6	211	0
	F	18:14	73%	7.0	21.1	5.5	141	10.7
Flow-through	I			7.2	21.7	7.8	9	0
	F	21:54	0%	6.5	22.0	7.6	13	0

### *Transport Trials*

Results of these trials indicated that our experimental procedures accurately simulate real world conditions.

Barramundi were transported live from Cairns to Brisbane / Sydney (duration 6 hours) at water:fish ratios of 2:1 with 100% survival, and from Cairns to Hong Kong (14 hours duration) at 2:1 with 100% survival. However, a commercial operation attempting to transport barramundi from Cairns to Sydney, using identical techniques, was unsuccessful. Temperate marine species were transported from Launceston to Cairns (duration 15 hours) at 3:1 with 92% survival, and from Launceston to Hong Kong (17 hours duration) at 3:1 with 66% survival.

## Discussion

These research results provide important information on the processes that affect survival of finfish transported live. The major water quality effects experienced by fish during transport are:

1. low dissolved oxygen levels due to oxygen consumption by respiration;
2. accumulation of carbon dioxide from respiration;
3. depression of pH caused by carbon dioxide accumulation;
4. increased ammonia levels resulting from ammonia excretion.

It should be noted that, while most of these processes are the result of the metabolic processes of the fish, bacterial decomposition of waste products, and particularly of dead fish, also contributes to this water quality deterioration.

Most water quality degradation occurs rapidly, within the first hour after packing. Subsequent deterioration in water quality occurs relatively slowly and many parameters change little during the subsequent transport period. Similar patterns in water quality were obtained in studies using clownfish (*Amphiprion ocellaris*) by Chow *et al.* (1994). Based on these results, it appears that accumulation of carbon dioxide causes narcotisation of the fish, slowing their metabolic rate and hence reducing the rate of oxygen consumption, and further carbon dioxide excretion.

It is this water quality degradation that causes fish mortality. Fish kept in conditions identical to those of transported fish, but provided with good quality water in a flow-through system, suffered no mortality. Fish subjected to vigorous aeration in simulated transport conditions suffered low mortality: 0% for banded morwong, and 17% for barramundi. Carbon dioxide levels in these treatments were low: 27 and 11 mg/l for barramundi and banded morwong respectively, compared with 137 and 99 mg/l for the standard packaging (Table 1, Table 2). Low levels of carbon dioxide in the aeration treatment resulted from carbon dioxide gas being removed from the transport containers by vigorous aeration. Ammonia levels in the aeration treatments were also low (10.7 and 2.2 mg/l for barramundi and banded morwong respectively) due to off-gassing of NH<sub>3</sub> by vigorous aeration. These results indicate that removal of carbon dioxide and ammonia by aeration substantially improves fish survival during transport.

The application of oxygen to the transport boxes did not have the same effect in terms of carbon dioxide or ammonia removal (Table 1, Table 2) because of the less vigorous application of oxygen compared with aeration. Carbon dioxide levels in the oxygenated treatment (barramundi) were 102 mg/l and ammonia levels were 23.8, the highest for all treatments in this experiment (Table 1). It appears that increased oxygen levels in the oxygenated treatment allowed the fish to compensate for increased hypercapnia caused by the build-up of carbon dioxide. The higher levels of ammonia experienced in this treatment apparently had little or no detrimental effect on fish survival.

Overall, these results indicate that carbon dioxide accumulation is the major limiting factor affecting survival of fish during live transport. High carbon dioxide levels cause hypercapnia, and narcotise and eventually kill the fish. However, the narcotisation of the fish at sub-lethal carbon dioxide levels may be an important factor in reducing the metabolic rate of fish transported in closed containers. It appears from these trials that narcotisation reduced the accumulation of metabolites from 1-2 hours after packing. Although control of carbon

dioxide levels is a desirable method for improving water quality in live fish transport applications, it may be better to maintain low carbon dioxide levels to provide some degree of narcotisation, and thus reduce the rate of accumulation of metabolites, rather than aiming to remove all carbon dioxide from the transport system.

## **References**

- Amend, D.F., Croy, T.R., Goven, B.A., Johnson, K.A. and McCarthy, D.H. (1982). Transportation of fish in closed systems: methods to control ammonia, carbon dioxide, pH, and bacterial growth. *Transactions of the American Fisheries Society* 111, 603-611.
- Berka, R. (1986). 'The Transport of Live Fish - A Review'. Food and Agriculture Organization of the United Nations, Rome, European Inland Fisheries Advisory Commission Technical Report 48, 52 pp.
- Boyd, C.E. (1979). *Water Quality in Warmwater Fish Ponds*. Auburn University, Alabama. 359 pp.
- Boyd, C.E. (1990). *Water Quality in Ponds for Aquaculture*. Auburn University, Alabama. 482 pp.
- Chow, P.S., Chen, T.W. and Teo, L.H. (1994). Physiological responses of the common clownfish, *Amphiprion ocellaris* (Cuvier), to factors related to packaging and long-distance transport by air. *Aquaculture* 127, 347-361.
- Burton, D. (1988). Further assessment of a pharmacological effect of tris buffer. *Comparative Biochemistry and Physiology* 90, 263-265.
- Froese, R. (1988). Relationship between body weight and loading densities in fish transport using the plastic bag method. *Aquaculture and Fisheries Management* 19, 275-281.
- Innes-Taylor, N. and Ross, L.G. (1988). The use of hydrogen peroxide as a source of oxygen for the transportation of live fish. *Aquaculture* 70, 183-192.
- McCrary, J.P. and Millard, J.L. (1978). III. Transportation of warmwater fishes. In: *Manual of Fish Culture*. Section G. Fish Transportation. US Fish and Wildlife Service, Washington, D.C. pp. 43-88.
- McFarland, W.N. and Norris, K.S. (1958). The control of pH by buffers in fish transport. *California Fish and Game* 44, 291-310.
- Piper, R.G., McElwain, I.B., Orme, L.E., McCrary, J.P., Fowler, L.G. and Leonard, J.R. (1982). *Fish Hatchery Management*. American Fisheries Society, Bethesda, MD. 517 pp.

# Physiological responses of barramundi *Lates calcarifer* to water quality deterioration during simulated live transport: acidosis, red-cell swelling, and levels of ions and ammonia in the plasma

B.D. Paterson<sup>1</sup>, M.A. Rimmer<sup>2</sup>, G.M. Meikle<sup>2</sup> and G.L. Semmens<sup>2</sup>

1 Queensland Department of Primary Industries, Centre for Food Technology, 19 Hercules St., Hamilton, Queensland 4007.

2 Queensland Department of Primary Industries, Northern Fisheries Centre, PO Box 5396, Cairns, Queensland 4870.

## Abstract

Water is a major expense when air-freighting live fish. However, if you reduce the volume of water relative to the amount of product then you foul the water faster with carbon dioxide (CO<sub>2</sub>) and ammonia (NH<sub>3</sub>). Studying how the fish respond to high levels of these wastes may show what factors are most important and indicate ways to circumvent this problem. The physiological responses of seawater-adapted barramundi, *Lates calcarifer*, were studied during simulated live transport and transport under circumstances of elevated CO<sub>2</sub> or NH<sub>3</sub>. Blood samples were removed from fish exposed to these treatments and compared to samples from control fish, (free in the tank) and fish confined in a box but with free-flowing seawater. Analysing the blood samples showed that simulated transport caused the plasma pH of the fish to fall, threatening the blood's ability to transport oxygen, but the red blood cells apparently defended their internal pH and oxygen transport capacity, and swelled measurably as a result. Exposing fish to unusually high carbon dioxide or ammonia levels caused plasma pH to fall to near lethal levels. The effects of both of these wastes need to be considered when studying the responses of barramundi to live transport. Water quality parameters during fish transport do not act in isolation. Attempts to reduce carbon dioxide accumulation, for example by using a buffer to control the water pH, may influence the fish's ability to excrete ammonia.

## Introduction

Water is a major expense when air-freighting live fish. If you reduce the volume of water relative to the amount of fish then you foul the water faster with the wastes that the fish excrete, carbon dioxide (CO<sub>2</sub>) and ammonia (NH<sub>3</sub>). Much of our knowledge of the physiological responses of fish to adverse water quality has been gained in studies of freshwater species, particularly the rainbow trout *Oncorhynchus mykiss* (Perry 1982, Thomas *et al.* 1988).

The barramundi or Asian sea bass *Lates calcarifer* is cultured widely throughout South-east Asia. However, virtually nothing is known about its physiological responses to handling and poor water quality. Understanding how a fish such as a barramundi responds to stagnating water allows us to understand why the fish die and leaves us better placed to make decisions about modifying the transport methods applied to this and other species.



### ***Fish blood and respiration***

Fish blood serves two functions that impinge greatly on a fish's response to transport stress. The blood transports oxygen that the fish absorbs from the water and at the same time carries toxic wastes such as carbon dioxide and ammonia which must be excreted from the fish.

Fish blood, like that of humans, is made of cells circulating within a fluid (the plasma). The blood has a characteristic colour because most of the cells present are red (the red blood cells). These red cells contain a red-coloured molecule called haemoglobin. Haemoglobin collects oxygen diffusing into the blood plasma in the gills and then loses it when the blood passes through tissues that are consuming oxygen. The oxygen stored on haemoglobin substantially augments the limited amount of oxygen that can be carried in solution in the blood plasma.

### ***Carbon dioxide and ammonia in blood plasma***

From what we know about the fate of carbon dioxide and ammonia in fish blood we can predict that a number of processes may be important. Firstly, high levels of carbon dioxide are probably lethal to fish because it impairs the oxygen transport capacity of fish blood (Berka 1986). Secondly, carbon dioxide gas behaves as an acid when dissolved in water. It readily enters the blood plasma as non-toxic bicarbonate ions and makes the plasma more acidic. Accumulation of acid in the plasma can have detrimental effects on the fish.

Low pH also impairs the oxygen carrying function of haemoglobin. The red blood cells of trout defend their internal pH against a fall in blood plasma pH using ionic 'pumps' built into their cell envelopes. The acid ( $H^+$ ) is removed from the cells, and one of the consequences of this is that 'salt' (especially sodium ion,  $Na^+$ ) is loaded into the cell. The osmotic pressure rises within and water follows the salt, causing the red blood cells to swell. This response can be shown clinically by a rise in the volume of red cells in the blood (measured as the haematocrit) without at a rise in haemoglobin concentration in the blood.

### ***Simulated transport of barramundi***

The physiological responses of seawater-adapted barramundi were studied during simulated live transport, and transport under circumstances of elevated  $CO_2$  or  $NH_3$ . Four treatments and a control were used:

1. 'Flow-through': fish were placed in polystyrene boxes which were fitted with inlet and outlet systems to allow flow through of sea water from the NFC supply. This treatment tested the 'confinement effect' of fish being held in boxes with optimal water quality.
2. 'Standard': fish were placed in seawater in a double-lined plastic bag (about 3 litres of seawater per kg of fish) that was inflated with oxygen, tied and then placed in a polystyrene seafood box. This is the standard small scale packaging technique used by live seafood exporters.
3.  $+NH_3$ : fish were packed as for the 'standard pack' treatment, but  $NH_4Cl$  was added to the bags before they were sealed. The initial concentration of  $NH_3$  in this experiment was designed to reflect  $NH_3$  levels after 20 hours of transport in sealed transport containers.

4. +CO<sub>2</sub>: again, the packaging used was identical to the standard pack treatment, but CO<sub>2</sub> was added so that initial CO<sub>2</sub> levels reflected those normally experienced after 20 hours of transport.
5. 'Control': control fish were retained in 2,000-litre fibreglass tanks with a flow-through water supply at NFC.

Two or three replicates of each treatment were used, and 4-5 fish were placed in each replicate box. Water:fish ratios were around 3:1 (range 2.5:1 - 3.4:1). Water quality was measured at the beginning and the end of the experiment (Table 4). Dissolved oxygen was measured using a Yellow Springs Instruments™ Model 58 dissolved oxygen meter. Carbon dioxide was measured using the phenolphthalein titration procedure described by Boyd (1979). Ammonia was measured according to the indophenol method (Boyd 1979) using a Bausch and Lomb Spectronic 21™ spectrophotometer, after the samples had been diluted with de-ionized water by a factor of 1:25 to bring them within the readable range of this test. pH was measured with a Mettler Delta 350™ pH meter and Mettler Ionode™ pH probe. Temperature was recorded at a 10 minute interval using either a Datataker™ DT5 single channel temperature logging module or a Hastings Hobo™ TI537 temperature logger and then downloaded to computer. The water temperature ranged from 19.9 to 22.0°C during the experiment.

Blood samples were removed from the caudal sinus of fish exposed to these treatments for 20 hours. The whole blood samples were drawn into heparinised, ice-cold plastic syringes and analysed for:

1. haematocrit, using heparinised glass capillary tubes and a haematocrit centrifuge;
2. haemoglobin concentration using Sigma catalogue 525A.

Plasma was also separated by centrifugation and plasma pH was determined immediately using a Radiometer microcapillary pH electrode and a Radiometer BMS III thermostatted to the experimental temperature. The plasma was then frozen and thawed when ready for analysis of ammonia concentration using the Berthelot reaction (Sigma catalogue 640A). The remaining plasma was re-frozen and sent to the DPI Animal Research Institute for determination of plasma ions. The concentration of sodium and potassium ions were analysed using an Electrolyte 2 Analyser using ion-selective electrodes. Concentrations of magnesium and calcium were determined spectrophotometrically using the Calgamite method and the Arsenazo III method respectively (Trace Scientific P/L). The concentration of Chloride was determined by titration of small samples using a Corning 925 chloride meter.



**Figure 9** (Above) Sampling blood from caudal vein of barramundi. (Below) Undertaking blood pH analysis.

**Table 4** Mean water quality measurements at the start of simulated transport trials with barramundi, and final measures after approximately 20 hours of simulated transport. See text for details of treatments used.

		Treatment			
		Flow-through	Standard	+NH <sub>3</sub>	+CO <sub>2</sub>
DO (mg/l)	Initial	7.2	7.1	7.6	5.9
	Final	6.5	2.2	2.5	7.0
pH	Initial	7.8	7.8	7.7	5.6
	Final	7.6	5.5	5.4	5.5
Total CO <sub>2</sub> (mg/l)	Initial	9.3	11.2	10.7	211.1
	Final	13.4	112.5	117.7	141.2
Total NH <sub>3</sub> (mg/100ml)	Initial	<0.5	<0.5	12.6	<0.5
	Final	<0.5	10.3	21.6	10.7

**Table 5.** Effect of water quality on blood and plasma physiology of barramundi subjected to simulated transport conditions for 20 hours as described above. Abbreviations: Hct: haematocrit; Hb: blood haemoglobin concentration; MCHC: mean cell haemoglobin concentration; and Total NH<sub>3</sub>: total ammonia concentration. Parameters are given as means. For each row, means sharing the same letter are not significantly different at P>0.05. Number of surviving fish sampled = n. For other abbreviations, refer to Table 4.

	Treatment				
	Control	Flow-through	Standard	+NH <sub>3</sub>	+CO <sub>2</sub>
No. of fish	16	13	11	9	4
Hct (%)	31.1c	32.4bc	36.0a	38.1a	36.0ab
Hb (g 100 ml <sup>-1</sup> )	10.06a	10.00a	10.00a	9.72a	8.88a
MCHC (g 100 ml <sup>-1</sup> )	32.35a	31.04a	27.82b	25.57c	24.77c
pH	7.707a	7.742a	7.451b	7.177c	7.055d
Total NH <sub>3</sub> (mg 100ml <sup>-1</sup> )	2.95a	3.29ab	3.49bc	3.85c	4.08c

### *Simulated shipment*

Blood plasma pH fell when barramundi were stored in closed conditions for 20 hours (Table 5). The acidosis was accompanied by a rise in the haematocrit of the blood. This occurred without a rise in blood haemoglobin concentration, which rules out recruitment of red cells from the spleen as an explanation. Therefore, it seems likely that the red cells have swollen while regulating their internal pH, as has been demonstrated in rainbow trout (Fievet et al., 1988). Red-cell swelling in some fish is enhanced by circulating hormones so a study of the mechanisms of this response in barramundi may prove fruitful.

### *Elevated carbon dioxide and ammonia*

Blood plasma pH fell lower when either the carbon dioxide or ammonia concentrations were at a high level from the very start of the storage period (Table 5). Some fish in these extreme treatments died, though their results are not considered here with the surviving fish. The very low pH associated with the high CO<sub>2</sub> and high NH<sub>3</sub> levels did not lead to further swelling of the red cells. It is quite conceivable that these fish are having trouble delivering oxygen to their tissues.

So why does the plasma pH fall? The explanation differs depending upon the nature of the waste product involved. High external levels of CO<sub>2</sub> will obviously lower the plasma pH by raising the carbon dioxide tension and HCO<sub>3</sub><sup>-</sup> level in the plasma (Perry 1982). To offset this, a means might be found to buffer the external water to maintain a higher pH. Incidentally, carbon dioxide also anaesthetises fish, which may explain the higher oxygen levels after this treatment (Table 4).

Something else has happened in the high ammonia treatment. The external pH and CO<sub>2</sub> level in the high ammonia treatment was comparable to that of the standard pack (Table 4), so these parameters cannot explain the lower pH in the blood plasma of the ammonia-treated fish. On the face of it, you expect that storing barramundi in a high total ammonia concentration will cause ammonia to accumulate in their blood. However, the high ammonia treatment had no effect on the ammonia level in the blood plasma (Table 5). The barramundi were still excreting ammonia.

Two mechanisms may be responsible. Firstly, the difference in pH between the blood and plasma and the water favours the diffusion of gaseous NH<sub>3</sub> from the fish by keeping the level of the gas in the water at a minimum. Secondly, the fish may be expending energy by actively exchanging outgoing ammonium ions (NH<sub>4</sub><sup>+</sup>) at the gills for incoming sodium (Na<sup>+</sup>) or hydrogen (H<sup>+</sup>) ions (Walsh and Henry 1991). This last mechanism is a possible explanation for why the plasma pH of fish in the high ammonia treatment was lower than that of fish in the standard pack. Further studies of waste excretion of barramundi under simulated transport conditions are required to explain why high ammonia levels by themselves can cause plasma acidosis.

### *Ion levels in the plasma*

Control of blood or plasma pH in aquatic animals is intimately associated with ionic regulation (Walsh and Milligan 1989). Adjustments in levels of ions in fluids either side of cell membranes occurs in order to move hydrogen ions from one side of the membrane to another, and we have already mentioned the role of sodium ions in the process of cell swelling. Of course, ionic concentrations must also be regulated within certain physiological limits. The levels of ions in the plasma of fish are regulated through interchange with ions in the tissues themselves, and are exchanged to and from the environment (in this case the shipment water) via the gills, alimentary canal and kidney. Some ions, such as potassium must remain within fairly tightly controlled limits because changes in the ratio of sodium to potassium across cell membranes actually define the membrane potentials that allow a fishes muscles and nervous system to operate.

Simulated live transport had a major impact on the ionic composition of the blood plasma (Table 6). Doing an analysis of variance on the ionic data is difficult because the more extreme treatments have larger standard deviations (which you expect when the closely regulated system seen in a normal fish breaks down) and unequal sample sizes (because several fish in these treatments died). However, from the table you can see that simulated shipment raised the sodium ( $\text{Na}^+$ ) and magnesium ( $\text{Mg}^{2+}$ ) concentration of the plasma. The chloride ( $\text{Cl}^-$ ) concentration fell at the same time. The changes in chloride and sodium explained most of the increase in the 'strong ion difference' (SID, i.e. the sum of major positively charged ions less the amount of negatively charged ions) (Table 6). Relative to the concentration in control fish, a large increase also occurred in plasma  $\text{K}^+$  concentration whereas plasma  $\text{Ca}^{2+}$  level seemed unaffected by the experiment (except in the standard box treatment).

**Table 6** Effect of water quality on plasma ion concentrations ( $\text{mmol l}^{-1}$ ) in barramundi subjected to a simulated transport trial for 20 hours in experimental conditions described above. Average values shown, with standard deviations in brackets. Number of surviving fish sampled = n. For other abbreviations, refer to Table 4.

	Treatment				
	Control	Flow	Standard	+ $\text{NH}_3$	+ $\text{CO}_2$
n	16	13	11	9	4
$\text{Cl}^-$	145 (4.5)	141 (4.9)	123 (10.0)	125 (12.0)	108 (9.7)
$\text{Na}^+$	173.2 (1.88)	173.3 (2.84)	181.6 (5.20)	180.1 (5.42)	179.8 (6.52)
$\text{K}^+$	4.12 (0.37)	4.41 (0.77)	5.10 (0.71)	6.52 (1.21)	7.15 (1.70)
$\text{Mg}^{2+}$	0.88 (0.05)	0.91 (0.07)	1.2 (0.12)	1.62 (0.39)	2.48 (0.88)
$\text{Ca}^{2+}$	2.52 (0.09)	2.61 (0.06)	2.86 (0.40)	2.53 (0.35)	2.50 (0.32)
SID	35.8 (5.04)	40.1 (5.61)	67.8 (7.39)	65.4 (11.48)	83.6 (10.9)

Regression analysis of ionic concentrations against plasma pH allows these trends to be examined in greater detail. Since pH is the negative logarithm (base 10) of the hydrogen ion concentration, it is first helpful to convert the pH to the hydrogen ion or proton concentration prior to doing regression analysis. Ignoring the treatment effects per se, plasma ion levels

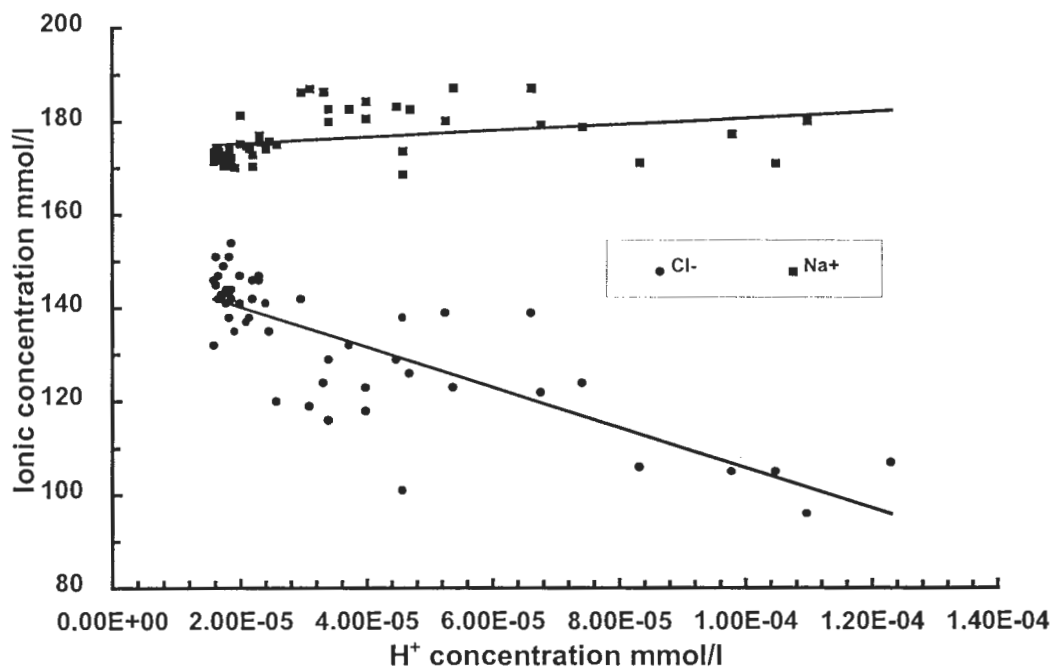

**Figure 10** Relationship between plasma proton ( $H^+$ ) concentration and the concentration of major ions (chloride and sodium) in the plasma of barramundi subjected to simulated live transport trials.

with the exception of sodium ion [ $Na^+$ ] and calcium [ $Ca^{2+}$ ] correlated well with the proton concentration of the plasma. Plasma  $Cl^-$  level was negatively correlated and both plasma [ $Mg^{2+}$ ] and [ $K^+$ ] positively correlated to  $H^+$  concentration as shown in the following equations.

$$\begin{aligned}
 [Cl^-] &= -4.288E+05[H^+] + 148.76 & (r^2= 0.633) \\
 [Mg^{2+}] &= 19252.2 [H^+] + 0.503 & (r^2= 0.873) \\
 [K^+] &= 35463.1 [H^+] + 3.69 & (r^2= 0.546)
 \end{aligned}$$

The strength of this relationship suggests that most of the changes in plasma ions may in fact be explained primarily by changes in plasma pH, regardless of the treatment.

The fall in  $Cl^-$  level as the  $H^+$  concentration rises (Figure 10) is readily characterised as linked to exchange of  $HCO_3^-$  at the gills- a mechanism of adjusting plasma pH (Heisler 1986). The explanation for the rise in magnesium (Figure 11) is not straightforward since this ion attracts little attention in the literature (which largely deals with freshwater species), but appears to be a sensitive index of transport stress in marine species (E. Boglio, pers. Comm.). This ion is present in large amounts in sea water and generally, marine animals keep their blood or plasma magnesium levels very low. Unlike sodium and chloride, which are controlled primarily through ionic regulation at the gills, fish excrete magnesium and potassium via their kidneys. Experiments show that plasma  $Mg^{2+}$  concentration also rises in the marine banded morwong (*Cheilodactylus spectabilis*) during simulated transport (P. de Guingand, unpublished data). It may be that, as seen in penaeid prawn broodstock, (Boglio, in prep.)

seawater-adapted barramundi have difficulty excreting magnesium when stressed. It is possible that in both barramundi and banded morwong, the low plasma pH associated with simulated shipment disturbs ion exchange in the kidney tubules.

The severe acidosis accompanying the high CO<sub>2</sub> and ammonia treatments was associated with substantially elevated plasma Mg<sup>2+</sup> and K<sup>+</sup> levels (Figure 11). Plasma K<sup>+</sup> concentration

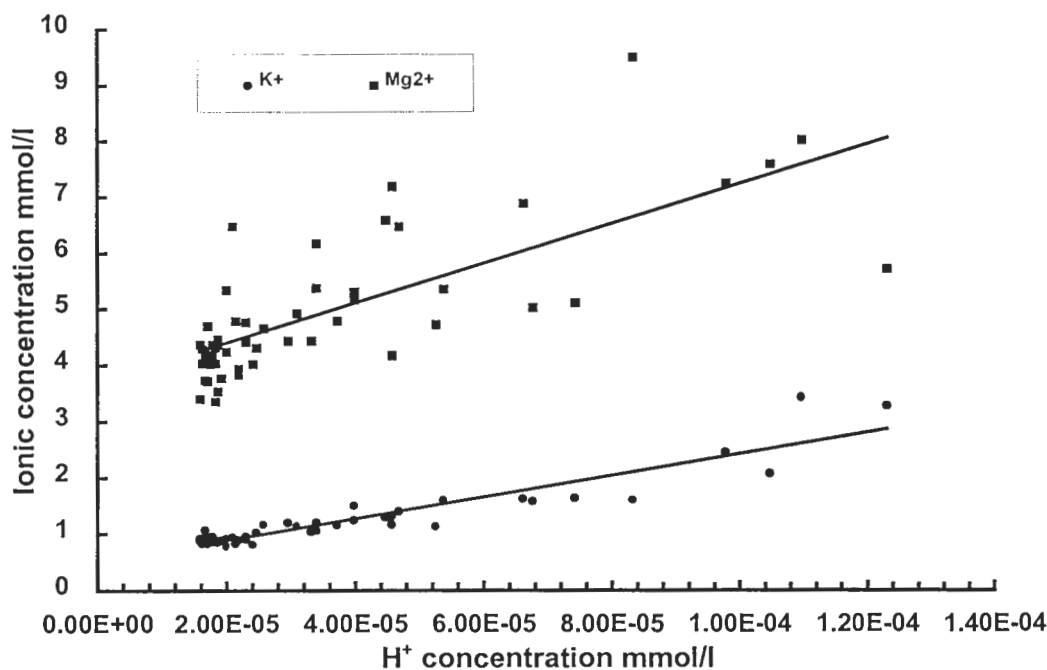

**Figure 11** Relationship between plasma proton concentration and concentrations of magnesium (Mg<sup>2+</sup>) and potassium (K<sup>+</sup>) in the plasma of barramundi subjected to simulated live transport trials.

increases when the rainbow trout (*Oncorhynchus mykiss*) experiences acidosis, perhaps indicating that this ion is moving out of the cells in exchange for H<sup>+</sup> entering (Eddy *et al.* 1979, Wheatly *et al.* 1984, Dimberg and Hoglund 1987, Perry *et al.* 1987). This symptom is most evident at death, when blood circulation ceases, and the plasma potassium level rises even higher as more of this ion leaches from the potassium-rich contents of the cells.

### Conclusions and practical implications

Confining barramundi in closed boxes with rising carbon dioxide and ammonia levels caused a fall in plasma pH, disturbance in plasma ionic concentrations and a compensatory swelling of the red blood cells that may help sustain respiration under the conditions experienced during live transport. Exposing fish to very high levels of carbon dioxide or ammonia decreased the plasma pH even more, caused further disturbances in plasma ion levels and killed some fish. Since the major problem for the fish seems to be low blood plasma pH, it seems to make sense to use a non-toxic buffer to keep the pH of the external medium from



falling. However, the situation is not that straightforward because raising the pH could have consequences for the way ammonia is excreted from the fish.

## References

- Berka, R. (1986). The transport of live fish. A review. EIFAC Technical Report 48, 52 pp.
- Boyd, C.E. (1979). Water Quality in Warmwater Fish Ponds. Auburn University Agricultural Experiment Station, Auburn, Alabama. 359 pp.
- Dimberg, K. and Hoglund, L.B. (1987). Carbonic anhydrase activity in the blood and the gills of rainbow trout during long-term hypercapnia in hard, bicarbonate rich freshwater. *Journal of Comparative Physiology B* 157, 405-412.
- Eddy, F.B., Smart, G.R. and Bath, R.N. (1979). Ionic content of muscle and urine in rainbow trout *Salmo gairdneri* Richardson kept in water of high CO<sub>2</sub> content. *Journal of Fish Diseases* 2, 105-110.
- Fievet, B., Claireaux, G., Thomas, S. and Motais, R. (1988). Adaptive respiratory responses of trout to acute hypoxia. III. Ion movements and pH changes in the red blood cell. *Respiration Physiology* 74, 99-114.
- Heisler, N. (1986). Mechanisms and limitations of fish acid-base regulation. In S. Nilsson and S. Holmgren, (Eds). *Fish Physiology - Recent Advances*. pp 24-29.
- Perry, S.F. (1982). The regulation of hypercapnic acidosis in two salmonids, the freshwater trout (*Salmo gairdneri*) and the seawater salmon (*Onchorynchus kisutch*). *Marine Behaviour and Physiology* 9, 73-79.
- Perry, S.F., Malone, S. and Ewing, D. (1987). Hypercapnic acidosis in the rainbow trout (*Salmo gairdneri*). I. Branchial ionic fluxes and blood acid-base status. *Canadian Journal of Zoology* 65, 888-895.
- Thomas, S., Fievet, B., Claireaux, G. and Motais, R. (1988). Adaptive respiratory responses of trout to acute hypoxia. I. Effects of water ionic composition on blood acid-base status response and gill morphology. *Respiration Physiology* 74, 77-90.
- Walsh, P.J. and Henry, R.P. (1991). Carbon dioxide and ammonia metabolism and exchange. In P.W. Hochachka and T.P. Mommsen, (Eds). *Biochemistry and Molecular Biology of Fishes*. Vol 1. Elsevier Science, pp 181-207.
- Walsh, P.J. and Milligan, C.L. (1989). Coordination of metabolism and intracellular acid-base status: ionic regulation and metabolic consequences. *Canadian Journal of Zoology* 67, 2994-3004.
- Wheatly, M.G., Hobe, H.A. and Wood, C.M. (1984). The mechanisms of acid-base and ionoregulation in the freshwater rainbow trout during environmental hyperoxia and subsequent normoxia. II. the role of the kidney. *Respiration Physiology* 55, 155-173.

# The use of temperature reduction as an aid to the transportation of live finfish

M.A. Rimmer<sup>1</sup>, P.F. de Guingand<sup>3</sup> and G.M. Meikle<sup>1</sup>

1 Queensland Department of Primary Industries, Northern Fisheries Centre, PO Box 5396, Cairns, Queensland 4870.

2 Southern Ocean Products, 'The Gulch', Bicheno, Tasmania 7215.

## **Abstract**

The use of temperature reduction was evaluated as a method for reducing mortality in live fish transport applications by reducing fish metabolism. Barramundi (*Lates calcarifer*) and banded morwong (*Cheilodactylus spectabilis*) were subjected to slow and rapid cooling regimes of 5 and 8 or 10°C below ambient temperature, and then subjected to simulated transport trials. Most temperature reduction treatments improved water quality significantly. Best survival (89%) of barramundi was achieved by reducing water temperature by 10°C at the slow cooling rate, while for banded morwong, all temperature reduction treatments significantly improved survival.

## **Introduction**

As noted in earlier chapters of this report, the main factors influencing survival of transported fish are changes in water quality caused by the accumulation of metabolic products, particularly carbon dioxide. There are basically two ways of moderating these water quality changes:

1. reduce the accumulation of metabolic products by reducing the metabolic rate of the fish during transport, and
2. remove metabolic products using some form of filtration or absorption technology.

Methods for reducing the accumulation of metabolic products are examined in this chapter, and the removal of these products from fish transport containers is examined in subsequent chapters.

Reduction of the metabolic rate of fish can be undertaken using chemical anaesthesia or by reducing water temperature. Both chemical anaesthesia and water temperature reduction can be used to induce different levels of anaesthesia, ranging from light sedation to medullary collapse; these levels are defined in Table 7.

**Table 7** Classification of behavioural changes in fishes during anaesthesia (Piper *et al.* 1982). Optimal level of anaesthesia for live fish transport corresponds to State I (light to deep sedation).

Levels of anaesthesia			Behavioural responses of fish
State	Plane	Description	
0		Normal	Reactive to external stimuli; equilibrium and muscle tone normal
I	1	Light sedation	Slight loss of reaction to external stimuli (visual and tactile)
I	2	Deep sedation	No reaction to external stimuli except strong pressure; slight decrease in opercular rate
II	1	Partial loss of equilibrium	Partial loss of muscle tone; reaction only to very strong tactile and vibrational stimuli; rheotaxis present, but swimming capabilities seriously disrupted; increased opercular rate
II	2	Total loss of equilibrium	Total loss of muscle tone; reaction only to deep pressure stimuli; opercular rate decreased below normal
III		Loss of reflex reactivity	Total loss of reactivity; respiratory rate very slow; heart rate slow
IV		Medullary collapse	Respiratory movements cease, followed several minutes later by cardiac arrest

### ***Chemical anaesthesia***

There are a number of chemical anaesthetics available for use on finfish, and the use of these is reviewed by Bell (1967), Taylor and Solomon (1979) and Ross and Ross (1984). Several fish anaesthetics, such as MS222 (ethyl m-aminobenzoate methanesulphonate) and benzocaine (ethyl p-aminobenzoate), are believed to be in use at present in live fish transport applications. More recently, the use of clove oil has been promoted as an anaesthetic for use on fish (Soto and Burhanuddin 1995), and a derivative of clove oil (Aqui-S™) is being promoted for use in live seafood transport applications (Goodrick *et al.* 1995). However, no anaesthetic is currently registered for use in food fish in Australia; thus, the use of anaesthetics with fish for human consumption in Australia is illegal. The issue of National Registration Authority approval for chemicals and anaesthetics for live fish transport is currently under investigation by the Fisheries Environment and Health Committee of the Standing Committee on Fisheries. In the event that anaesthetics are registered for use with finfish in the future, it is likely that a withholding period will be required following use of the anaesthetic, and that this withholding period (several weeks to several months) will exceed the duration that live fish are normally held following transport (*c.* 1 week). Because of the legal problems associated with the use of anaesthetics for live food fish, this project did not investigate the application of anaesthetics for live fish transport.

### ***Temperature reduction***

Because fish are poikilothermic, lowering the temperature of their environment will reduce body temperature and hence metabolic rate. Temperature reduction is currently widely used

in live fish transport, but without any real data as to the optimal transport temperature for each species and the optimal rate of temperature change. Generally, temperature reduction is used to sedate, rather than fully anaesthetise, fish. Sedated fish show weak opercular movements, retain their sense of equilibrium, and may continue swimming to some extent (Yoshikawa *et al.* 1989). In comparison, opercular movements cease in anaesthetised fish, no swimming movements occur, and they lose equilibrium completely (McFarland and Klontz 1969, Yoshikawa *et al.* 1989).

Anaesthetisation of finfish requires fine temperature control, generally  $\pm 1^\circ\text{C}$  (Yoshikawa *et al.* 1989), which is difficult to regulate under commercial conditions. It is extremely difficult to maintain a particular level of anaesthesia without such fine temperature control, and even small changes in temperature can dramatically affect the anaesthesia state of the fish (Yoshikawa *et al.* 1989). This makes the commercial application of such a procedure difficult and expensive, since temperature in the transport containers may vary substantially during the transport period. In addition, mortality using cold anaesthesia techniques is often high, although mortality rates vary substantially between species (Yoshikawa *et al.* 1989). Anaesthetised carp (*Cyprinus carpio*) bled from the gills and showed signs of convulsion when they received external stimuli during cold anaesthesia (Yoshikawa *et al.* 1989). There has been considerable interest in using cold anaesthesia techniques to transport fish live without water, but to date this seems to have been only achieved on an experimental basis with a few fish species (Nakamura 1992). Many fish species are unable to tolerate prolonged cold air exposure (Nakamura 1992).

A more practical technique is induction of sedation using temperature reduction. Yoshikawa *et al.* (1989) suggested that light or deep sedation was the preferred stage of anaesthesia for live transport of carp. Reduction of water temperature from 23 to 14°C is sufficient to induce sedation in carp, and this temperature regime reduces the oxygen consumption rate of carp by about 50% (Yoshikawa *et al.* 1989). The temperature to which the fish are acclimated will significantly affect their thermal tolerances (Ross and Ross 1984, Yoshikawa *et al.* 1989, Steffens 1996). For example, blue-throat wrasse (*Notolabrus tetricus*) recorded static  $TL_{50}$ 's of approximately 5.0, 6.0 and 8.3°C at acclimation temperatures of 10, 15 and 20°C respectively (Steffens 1996). To provide results that can be readily applied to commercial operations, and to simplify the problem of varying acclimation temperatures, our experimental methods assessed survival after temperature reduction by a set differential, either 5 or 10°C for barramundi (*Lates calcarifer*), or 5 or 8°C for banded morwong (*Cheilodactylus spectabilis*).

### **Materials and Methods**

Juvenile barramundi, approximately 0.3-0.5 kg in weight, were obtained from a commercial barramundi farm and held for one month prior to the commencement of these experiments. Four days prior to the experiment, barramundi were moved to the cooling tanks and maintained there at ambient temperature to allow the fish to acclimate to the new tanks. Food was withheld from the barramundi during this time. Banded morwong, approximately 1 - 1.5 kg in weight, were caught by gill-net by local fishers and transported to the research facility. Fish were held for 7 -10 days prior to the commencement of the experiment to recover from capture stress. The banded morwong were not fed during this time.

Fish were either placed into the cooling tanks and the temperature reduced slowly ('slow cool' treatments), or placed immediately into pre-cooled water ('rapid cool' treatments). The cooling units used consisted of a plastic coated copper or galvanised steel cooling coil inside a 3 m<sup>3</sup> fibreglass or 1 m<sup>3</sup> polyethylene tank, and an adjacent refrigeration unit.

Barramundi were subjected to the following treatments:

Control: maintained at ambient temperature (23.3-29.1°C)

S5: slow cooling rate (0.5-1°C per hour), 5°C temperature decrease.

S10: slow cooling rate (0.5-1°C per hour), 10°C temperature decrease.

R5: rapid cooling rate (immediate transfer to cooled water), 5°C temperature decrease.

R10: rapid cooling rate (immediate transfer to cooled water), 10°C temperature decrease.

Banded morwong were subjected to the following treatments:

Control: maintained at ambient temperature (14.5-17.0°C).

S5: slow cooling rate (0.5-1°C per hour), 5°C temperature decrease.

S8: slow cooling rate (0.5-1°C per hour), 8°C temperature decrease.

R5: rapid cooling rate (immediate transfer to cooled water), 5°C temperature decrease.

R8: rapid cooling rate (immediate transfer to cooled water), 8°C temperature decrease.

Immediately after the cooling treatment, fish were removed from the cooling tanks and packed at the same temperature for a simulated transport period of 18 hours, as detailed in previous chapters. Following the simulated transport period, the boxes were opened and water samples taken for analysis of carbon dioxide, pH, and ammonia. Temperature and dissolved oxygen were analysed using a Yellow Springs Instruments Model 55 or Model 58 dissolved oxygen meter. Carbon dioxide was measured using the methods outlined in Boyd (1979) (barramundi), or using a La Motte portable titration kit (phenolphthalein indicator) (banded morwong). Ammonia-nitrogen was measured according to the indophenol method (Boyd 1979) using a Bausch and Lomb Spectronic 21 spectrophotometer (barramundi) or using a Lovibond colorimetric system (banded morwong). pH was measured with a Mettler Delta 350 pH meter and Mettler Ionode pH probe (barramundi), or using a Hanna H.9023 portable pH meter (banded morwong).

Statistical tests were undertaken using the software Statistix<sup>®</sup>. Mortality data were normalised using an arcsin transformation prior to analysis (Zar 1984). Differences between means were analysed using LSD (the statistical test, not the drug).

## **Results**

Mortality was significantly higher in the control group than in all cooling treatments for barramundi (ANOVA,  $F=10.3$ ,  $P<0.01$ ) and for banded morwong (ANOVA,  $F=2.9$ ,  $P<0.05$ ). For banded morwong, all cooling treatments resulted in significantly lower mortality, whereas for barramundi, the best survival was obtained for fish subjected to the M5 treatment (Table 8).

**Table 8** Mortality and water quality data for cooling trials undertaken with barramundi and banded morwong. All values are means. Similar superscript letters indicate means that are not significantly different from each other. Abbreviations: D.O.: dissolved oxygen; see text for treatment abbreviations.

Barramundi	Control	S5	S10	R5	R10
Mortality	80% <sup>a</sup>	23% <sup>c</sup>	11% <sup>b,c</sup>	38% <sup>b</sup>	43% <sup>b</sup>
D.O. (mg/l)	1.5 <sup>a</sup>	1.6 <sup>a</sup>	3.2 <sup>b</sup>	2.1 <sup>a</sup>	2.4 <sup>b</sup>
pH	5.7 <sup>a</sup>	5.5 <sup>b</sup>	5.7 <sup>a</sup>	5.7 <sup>a</sup>	5.7 <sup>a</sup>
Carbon dioxide (mg/l)	112 <sup>a</sup>	108 <sup>a</sup>	82 <sup>b</sup>	110 <sup>a</sup>	89 <sup>b</sup>
Ammonia (ppm)	15.6 <sup>a</sup>	12.2 <sup>a</sup>	16.3 <sup>a</sup>	12.8 <sup>a</sup>	15.0 <sup>a</sup>
Banded morwong	Control	S5	S8	R5	R8
Mortality	66% <sup>a</sup>	47% <sup>a,b</sup>	44% <sup>b</sup>	40% <sup>b</sup>	35% <sup>b</sup>
D.O. (mg/l)	5.9 <sup>a</sup>	5.8 <sup>a</sup>	5.2 <sup>a</sup>	5.1 <sup>a</sup>	4.9 <sup>a</sup>
pH	5.8 <sup>a</sup>	6.0 <sup>a</sup>	6.0 <sup>a</sup>	6.0 <sup>a</sup>	5.9 <sup>a</sup>
Carbon dioxide (mg/l)	99 <sup>a</sup>	84 <sup>b</sup>	81 <sup>b</sup>	83 <sup>b</sup>	76 <sup>b</sup>
Ammonia (ppm)	4.3 <sup>a</sup>	3.1 <sup>a</sup>	4.4 <sup>a</sup>	4.5 <sup>a</sup>	4.1 <sup>a</sup>

Of the water quality variables measured, there was no significant difference between dissolved oxygen and pH for banded morwong in all treatments, and only minor differences between treatments for barramundi. The M10 treatment for barramundi resulted in higher dissolved oxygen levels compared with other treatments (ANOVA,  $F=4.1$ ,  $P<0.01$ ). pH was lower in the M5 treatment for barramundi (ANOVA,  $F=4.1$ ,  $P<0.01$ ), but the difference (0.2) is only minor and probably insignificant in biological terms.

Carbon dioxide levels were lower in the M10 and R10 treatments for barramundi (ANOVA,  $F=4.2$ ,  $P<0.01$ ), and were lower for all cooling treatments with banded morwong (ANOVA,  $F=3.3$ ,  $P<0.05$ ). Ammonia levels were not significantly different for treatments with either fish species (Table 8).

### **Discussion**

The most notable improvement in survival using temperature reduction was with barramundi. Barramundi cooled by 10°C at the slow rate used in this experiment were subject to only 11% mortality, compared with 80% for fish kept in ambient conditions (Table 8). Banded morwong showed a less pronounced improvement in survival, from 66% to around 40% (Table 8). For barramundi, this improved survival was accompanied by improved water quality, in particular higher dissolved oxygen levels and lower carbon dioxide levels compared with the control group and most other treatments. The only water quality parameter in trials using banded morwong that differed significantly between control and treatment groups was carbon dioxide (Table 8), which was significantly lower in all cooling treatments. This result was associated with improved survival in all cooling treatments compared with the control group, but little variation in survival between the different treatments (Table 8).

These results provide additional evidence that survival of fish transported live is directly influenced by carbon dioxide and dissolved oxygen levels in the transport medium, either

singly, or in combination. It is notable that similar treatments had different levels of effect on barramundi and on banded morwong. Other researchers have noted that there are markedly different responses to temperature sedation by different fish species (Yoshikawa *et al.* 1989). In addition to variation between species, the response between individuals to a particular cooling treatment can also be significant. One factor that can influence fish survival is relative condition or the nutritional status of the fish (Nakamura 1992).

Our results indicate that survival of transported fish can be readily and easily improved by sedating fish using temperature reduction techniques. Overall, the best cooling treatment was the slow reduction (0.5-1°C per hour) of temperature by 10°C (barramundi) or 8°C (banded morwong). These treatments produced the lowest mortality rates, equivalent or higher dissolved oxygen levels, equivalent or higher pH, and lower carbon dioxide levels than other treatments (Table 8). Live fish exporters should utilise a similar approach in developing cooling protocols for packing and transporting live fish. Obviously, these protocols will vary between species, and will vary at different times of the year. However, by adopting a cooling procedure that reduces temperature by a set amount below ambient temperature, seasonal variation in acclimation temperature and transport temperature can be largely overcome. It should be noted that commercial shippers should always undertake experiments with small numbers of fish prior to attempting to undertake commercial shipment.

## References

- Bell, G.R. (1967) A guide to the properties, characteristics, and uses of some general anaesthetics for fish. Bulletin of the Fisheries Research Board of Canada 148. 9 pp.
- Goodrick, B., Exley, P., Jerrett, A. and Holland, J. (1995). How to live longer and suffer less, if you're a fish on the move. In: 'Live Seafood Handling: Strategies for Development'. Proceedings of a workshop held at Hobart, Tasmania, 13 October 1995. National Seafood Centre Project 92/125.26. pp. 134-136.
- McFarland, W.N. and Klontz, G.W. (1969). Chapter 26. Anesthesia in fishes. In: 'Anesthesia in Laboratory Animals'. Federation Proceedings 28(4), 1535-1540.
- Nakamura, K. (1992). Effect of precooling on cold air-tolerance of the carp *Cyprinus carpio*. Nippon Suisan Gakkaishi 58, 1615-1620
- Piper, R.G., McElwain, I.B., Orme, L.E., McCraren, J.P., Fowler, L.G. and Leonard, J.R. (1982). Fish Hatchery Management. American Fisheries Society, Bethesda, MD. 517 pp.
- Ross, L.G. and Ross, B. (1984). Anaesthetic and sedative techniques for fish. Institute of Aquaculture, University of Stirling, Scotland. 35 pp.
- Soto, C.G. and Burhanuddin. (1995). Clove oil as a fish anaesthetic for measuring length and weight of rabbitfish (*Siganus lineatus*). Aquaculture 136, 149-152.
- Steffens, A.M. (1996). The determination of the lower incipient lethal and critical thermal minima temperature of blue-throat wrasse (*Notolabrus tetricus*). MAppSc thesis, Australian Maritime College.

Taylor, A.L. and Solomon, D.J. (1979). Critical factors in the transport of live freshwater fish. III. The use of anaesthetics as tranquillizers. *Fisheries Management* 10, 153-157.

Yoshikawa, H., Ueno, S. and Mitsuda, H. (1989). Short- and long-term cold anaesthesia in carp. *Nippon Suisan Gakkaishi* 55, 491-498.

Zar, J.H. (1984). *Biostatistical Analysis*. Prentice-Hall, London. 718 pp.



# Removal of carbon dioxide in live fish transport

M.A. Rimmer<sup>1</sup>, J. Pennefather<sup>2</sup>, G.M. Meikle<sup>1</sup> and P.F. de Guingand<sup>3</sup>

- 1 Queensland Department of Primary Industries, Northern Fisheries Centre, PO Box 5396, Cairns, Queensland 4870.
- 2 Submarine and Underwater Medicine Unit, HMAS Penguin, Mosman, Sydney, NSW 2088.
- 3 Southern Ocean Products, 'The Gulch', Bicheno, Tasmania 7215.

## Abstract

The use of sodalime to reduce carbon dioxide accumulation in live fish transport applications was evaluated. Prototype live fish transport systems using sodalime were effective in reducing carbon dioxide levels and increasing pH in the transport medium. The prototype systems dramatically increased survival from 31% to 100% for barramundi (*Lates calcarifer*) and from 39% to 90% for banded morwong (*Cheilodactylus spectabilis*). Requirements for continued commercial development of these prototypes systems are discussed.

## Introduction

The results of our research on water quality factors that affect fish during transport, which are discussed in previous chapters, clearly indicate that accumulation of carbon dioxide is one of the major limiting factors in determining the survival of finfish transported in closed systems. Carbon dioxide reduces the pH of the transport water, which reduces the ability of the transported fish to utilise oxygen, and high levels of carbon dioxide are directly toxic to fish. Accumulation of carbon dioxide is also a problem in other applications where people or animals are breathing in a sealed system such as a space craft or submarine. The same problems are encountered in rebreathing diving sets (Edmonds *et al.* 1992, MacDougall 1994). Having established the need to reduce carbon dioxide levels in fish transport containers, we investigated whether reduction of carbon dioxide levels would increase fish survival during live transport, and whether existing technology used in diving applications could be applied to live fish transport.

The material commonly used to absorb carbon dioxide in a range of applications is sodalime. Dried sodalime is approximately 96% Ca(OH)<sub>2</sub> and 4% NaOH. Sodalime is commonly used in many military applications, including rebreather diving equipment, recompression chambers and in submarines to enable air to be recirculated. One kg of sodalime can absorb about 200 litres of carbon dioxide.

The experiments described in this chapter were designed to test whether:

1. commercially realistic prototype systems could be developed using rebreather principles;
2. the use of sodalime in a closed fish transport system improved water quality, particularly in terms of carbon dioxide levels and pH;
3. the prototype sodalime systems improved survival of fish compared with standard packaging techniques.

## Materials and Methods

Two prototype systems were developed using sodalime for carbon dioxide removal:

1. A small box system was constructed using a commercially available polyethylene container with lid. This box was insulated with expanded polystyrene sheets, and made completely sealable using a silicone bead on the lid. During each experiment the lid was clamped using welding pegs to ensure that the unit was completely sealed. Within the box a compartment was placed at one end to contain sodalime and associated equipment (Figure 12). Banded morwong (*Cheilodactylus spectabilis*) were used in experiments with the small box system.
2. A larger prototype was constructed using a 0.8 m<sup>3</sup> plastic 'Dyno' bin, fitted with a 12V aerator and a large sealed gel-acid battery. The lid was modified with a rubber seal so that the box remained airtight during trials. Barramundi (*Lates calcarifer*) were used in experiments with the large system.

Analytical, indicating sodalime was used in these trials. When exhausted, some of the sodalime granules turn blue, giving the sodalime a purple hue. Sodalime was contained either in a plastic 5 mL syringe (small box) or a 1-litre sealed canister (large box). Filter material was placed at each end of the sodalime canisters to prevent sodalime dust being blown into the box. Air hoses were connected to each end of the canister, with one air hose was connected to an aerator outlet and the other leading back to the box. The small box prototype used a 12V 3W aerator manufactured by CM Engineering (Sydney) which was powered by a 7 amp/h sealed lead acid battery. The large box prototype used a Dynavac™ Model OD3-12 12V pump with a rated capacity of 3.1 m<sup>3</sup>/h, powered by a 115 amp/h 12V gel battery. The inlet to the aerator drew air from the gas space in the box, pumped it through the sodalime canister, then back into the box, thus continually passing the gas through the sodalime to absorb carbon dioxide. One to two airstones (small box) or up to 15 airstones (large box) circulated the treated air through the transport water.

Control treatments used standard expanded polystyrene and plastic bag packing ('standard pack' treatment). All experiments were undertaken as simulated transport trials with a duration of around 18 hours; water:fish ratios used are listed in Table 9. A total of 12 and 9 replicate experiments were undertaken with the large and small prototypes respectively.

Temperature and dissolved oxygen were analysed using a Yellow Springs Instruments Model 55 or Model 58 dissolved oxygen meter. Carbon dioxide was measured using the methods outlined in Boyd (1979) (barramundi), or using a La Motte portable titration kit (phenolphthalein indicator) (banded morwong). Ammonia-nitrogen was measured according to the indophenol method (Boyd 1979) using a Bausch and Lomb Spectronic 21 spectrophotometer (barramundi) or using a Lovibond colorimetric system (banded morwong). pH was measured with a Mettler Delta 350 pH meter and Mettler Ionode pH probe (barramundi), or using a Hanna HI9023 portable pH meter (banded morwong).

Statistical tests were undertaken using the software Statistix®. Mortality data were normalised using an arcsine transformation prior to analysis (Zar 1984).

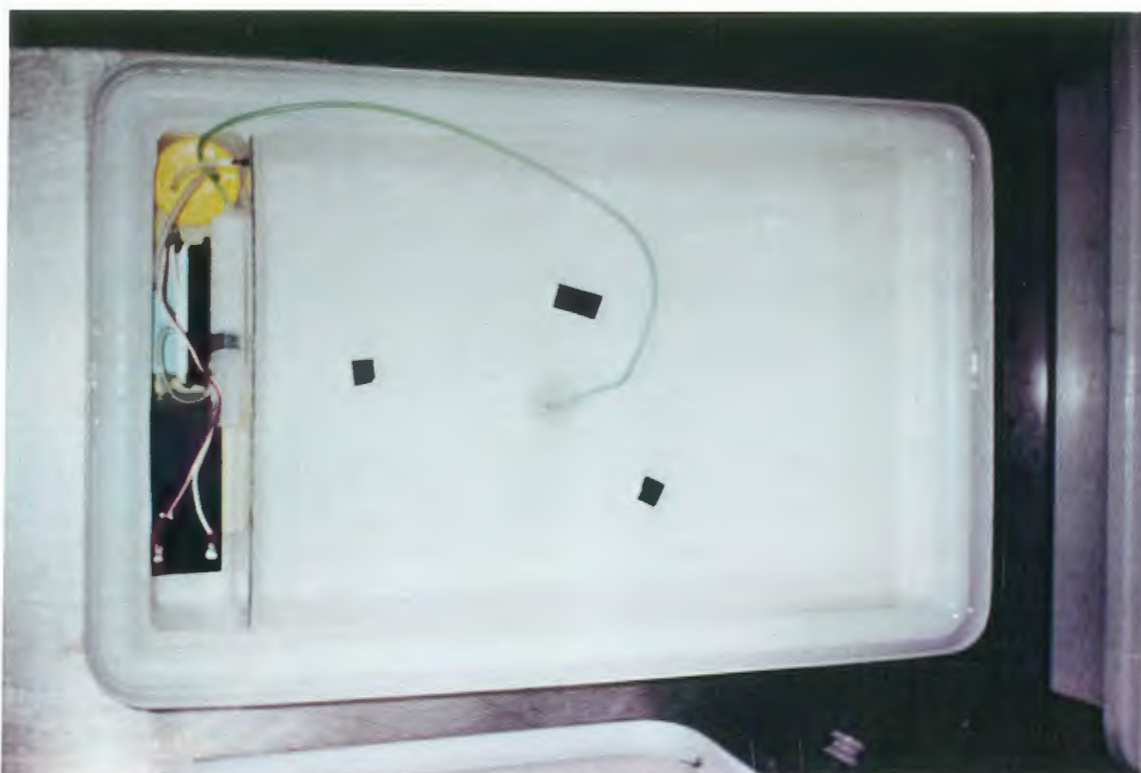

**Figure 12** Prototype live fish transport system, incorporating battery, air pump and sodalime canister.

### **Results**

Table 9 summarises the results of trials undertaken with the sodalime system, compared with the results of earlier experiments undertaken with standard packaging and techniques.

**Table 9** Summary of results of standard live fish transport packaging, and the sodalime system developed during this project. All values are means.

<i>Barramundi</i>	Standard packaging	Sodalime
Mortality	61%	0%
W:F ratio	2.8:1	1.9:1
Temperature	25.3 °C	25.3 °C
Dissolved oxygen	2.7 ppm	3.1 ppm
pH	5.5	6.9
Carbon dioxide	137 mg/l	33 mg/l
<i>Banded morwong</i>	Standard packaging	Sodalime
Mortality	69%	10%
W:F ratio	3.9:1	2.0:1
Temperature	14.8 °C	18.3 °C
Dissolved oxygen	5.5 ppm	1.7 ppm
pH	5.8	6.8
Carbon dioxide	98 mg/l	23 mg/l

### ***Survival***

Survival of banded morwong was significantly higher in the sodalime treatment group compared with control fish (t-test,  $t=5.3$ ,  $P<0.01$ ). Rigorous statistical analysis of the barramundi survival data was precluded by the consistent zero mortality data for the sodalime treatment.

### ***Carbon dioxide***

The mean carbon dioxide concentration at the end of the simulated transport trials was significantly lower in the sodalime treatment than in controls for trials using barramundi (t-test,  $t=19.3$ ,  $P<0.01$ ) and for banded morwong (t-test,  $t=10.3$ ,  $P<0.01$ ).

### ***Dissolved oxygen***

There was no significant difference in dissolved oxygen levels between sodalime treatment and control groups with barramundi (t-test,  $t=-1.74$ ,  $P>0.05$ ). However, in trials with banded morwong, dissolved oxygen levels were significantly higher in control groups than in the sodalime treatment (t-test,  $t=6.8$ ,  $P<0.01$ ).

### ***pH***

pH was significantly higher in the sodalime treatment than in controls in trials with barramundi (t-test,  $t=-17.7$ ,  $P<0.01$ ) and in trials with banded morwong (t-test,  $t=-5.6$ ,  $P<0.01$ ).

### ***Discussion***

These results show that reducing carbon dioxide levels in the transport medium significantly improves survival of transported fish. The prototype systems used reduced carbon dioxide to less than 25% of the levels found in standard packaging systems. As expected, the reduction in carbon dioxide levels resulted in higher pH values in the sodalime treatment. Depressed pH reduces the ability of fish haemoglobin to take up oxygen (see chapter on physiological effects of live fish transport), so that fish may die of hypoxia even when dissolved oxygen levels are relatively high.

In these experiments, there was no significant difference in dissolved oxygen levels between the sodalime treatment and controls in trials using barramundi. However, dissolved oxygen levels in the sodalime treatment using banded morwong were significantly lower than in controls. One reason for this result may be that the higher pH in the sodalime treatment using banded morwong allowed haemoglobin to more efficiently use oxygen than in the control group. An alternative explanation may be that narcotisation, caused by carbon dioxide accumulation, may have been reduced by the low levels of carbon dioxide in the sodalime treatment, thus allowing increased respiration by the fish.

The prototype systems used in this research gave significant increases in survival of transported fish, compared with standard packaging techniques, from 39% to 100% for

barramundi, and from 31% to 90% for banded morwong. Although the boxes constructed were only prototypes, they were constructed to be commercially realistic. There are some obvious operational penalties involved in using these systems, since additional weight is used by the life support equipment. This is more of a problem with the small box design than with the large box. As noted previously, large boxes of a similar design are already in use in Australia to export live fish, particularly from northern Queensland.

It is important to note that the systems developed were prototype systems only, intended to demonstrate that carbon dioxide can be readily removed and that this will increase fish survival. Further research and development is necessary to produce a commercially viable transport system based on this technology. In particular, the following issues need to be resolved:

1. Engineering issues: Improved design of the life support system is necessary to reduce weight and space taken up by the system. In particular, reduction in battery size and weight is important to increase the efficiency of the packaging system.
2. Biological issues: The amount of sodalime used must be matched to the biomass of fish transported and the expected production of carbon dioxide for different fish species. The amount of sodalime used should provide a small residual carbon dioxide level to slightly narcotise the fish, rather than totally removing carbon dioxide. Additional oxygen may also be necessary to compensate for higher rates of oxygen consumption.
3. Commercial testing: Further testing of an improved design is necessary to verify that it will function reliably in a commercial environment.

## **References**

Edmonds, C., Lowry, C. and Pennefather, J. (1992). *Diving and Subaquatic Medicine*. Butterworth Heineman.

MacDougall, S.A. (1994). Nitrox and rebreather diving. In: Wells, P.G. and Ricketts, P.J. (eds.). 'Coastal Zone Canada '94, Cooperation in the Coastal Zone'. Proceedings of a conference held at Halifax, NS (Canada), 20-23 Sep 1994. pp. 2069-2075

Zar, J.H. (1984). *Biostatistical Analysis*. Prentice-Hall, London. 718 pp.

## Road transport of live fish

**M.A. Rimmer**

Queensland Department of Primary Industries, Northern Fisheries Centre, PO Box 5396, Cairns, Queensland 4870.

### **Abstract**

The supply of fish live to markets is a 'value-adding' process, where the higher prices paid for live fish are dependent on fish arriving live at their destination. While this trade has been developing rapidly in Australia over the last few years, there have been technical and other difficulties in catching, holding and transporting fish for live markets. Many of these problems are associated with the inexperience of the operators concerned, and result from the fact that there is only a small experience base in Australia, particularly when compared with many overseas countries.

This report seeks to remedy the lack of information that is readily available on road transport of live fish. The information in this report was obtained from published sources and from conversations with commercial road transport operators in the US. The author visited commercial live fish transport operations in Arkansas, Texas and Louisiana. Road transport of live fish is a well established industry in the US and most of the techniques used are readily applicable to Australian conditions with minimal modifications.

The information in this report will enable operators to set up and run road transport operations for the live fish market. Some of the salient points discussed in the report are:

- matching truck size and design to specific needs
- use of insulated tanks
- transporting fish in dark or low light conditions
- design of tanks and loading systems to minimise fish handling
- provision of oxygen to compensate for oxygen consumed by respiration
- provision of water agitators to off-gas carbon dioxide
- use of liquid oxygen instead of gaseous oxygen
- provision of adequate amounts of oxygen during the loading procedure, when oxygen consumption is highest
- reduction of water temperature to reduce the metabolic rate of the fish during transport
- extensive pre-transport 'tempering' to adapt the fish to transport conditions
- effects of temperature and fish size on loading rates
- recommended loading rates for US finfish species.

Using the procedures and equipment described in this report, live fish transport operators in the US haul fish from the southern central US to markets on the east and west coasts, as far south as the Mexican border, and north into northern Canada. These trips can be up to 5 days in duration. Since the area covered by these operators exceeds the area of Australia, adoption of these procedures and equipment should enable successful road transport of live fish throughout Australia.

## **Introduction**

As the live fish trade has developed in Australia, there have been several attempts to set up road transport operations hauling live finfish to city markets. These trucks travel as far north as Cairns in far northern Queensland, south to Tasmania, and west to South Australia to pick up fish. The fish are generally transported to wholesalers in Sydney and Melbourne.

The Fisheries Research and Development Corporation (FRDC) sponsored a Live Fish Transport Workshop which was held in Brisbane in May 1994. At this workshop, industry representatives commented that most domestic transport of live finfish would take place by road transport, rather than by air freight. Industry representatives also commented on the lack of design information which is readily available to them to construct and operate cost-efficient road transport units for live finfish.

In contrast to the Australian situation, road transport of live finfish is a well established industry in the United States of America. In early 1995, I visited the US to undertake collaborative research on production of finfish for stocking and aquaculture. The study tour was primarily funded by the Department of Industry, Science and Technology, and the Queensland Department of Primary Industries. However, the visit provided an ideal opportunity to investigate techniques used for road transport of live finfish in the US, for application in Australia. Consequently, FRDC agreed to fund a proportion of the trip costs to permit the examination of road transport techniques in use in the US, as part of the research into the development of live fish transport techniques (FRDC projects 93/184 and 93/185). This report is a synthesis of published information, unpublished data, and conversations with road transport operators from commercial and government organisations in various parts of the US. All published information used in this report is cited in the text, and a list of those persons who contributed information is included in the acknowledgments section of this report.

## **Stress in Fish**

Like other aspects of transporting fish live to market (Rimmer *et al.* 1994), successful road transport of fish requires the reduction of stress in the fish to the greatest possible extent. Stress in fish manifests itself as a series of complex physical and physiological changes that affect the fish's health. Failure to reduce stress in fish during transport will result in decreased survival and increased incidence of disease. Obviously, these factors will adversely affect the cost effectiveness of the road transport operation.

Stress can be reduced by:

- placing fish in dark tanks
- providing optimal conditions of water quality, particularly with regard to the provision of oxygen, removal of carbon dioxide, and control of pH
- minimising the handling of fish.

Many aspects of the design and operation of live fish transport systems listed in this report are discussed in relation to reducing stress in the transported fish as much as possible. A check list of the items discussed in the report is included as Appendix 1.



Figure 1 Smaller live fish transport trucks used to carry fish to local markets.





**Figure 2** Large live fish transport trucks used to transport fish to interstate markets in the continental US and in Canada.

### ***Trucks for Live Fish Transport***

Trucks used for live fish transport range from small 1-tonne capacity utility type trucks up to large articulated units. Smaller trucks are used to carry smaller loads over shorter distances, such as baitfish to local bait store markets that may be up to several hours away by road (Figure 1). Smaller, more manoeuvrable trucks are also used to transport harvested fish from the pond to processing plants or to holding tanks where the fish are held for several days before they are transported to market.

Larger trucks (large non-articulated and articulated units) are used to transport larger loads over longer distances (Figure 2). These trucks may undertake trips of several days duration, such as from the southern US north as far as northern Canada. Operators of articulated trucks pointed out that these units are generally not suitable for use around ponds on fish farms, and that a non-articulated truck should be used if direct access to ponds is required.

One operator expressed dissatisfaction with one truck that had an aluminium tray, noting that the stress of driving the truck over irregular surfaces around the fish farm had caused bending of the tray and fracturing of the tray supports. He suggested that steel/wood trays are more suitable, being more resistant to bending, although more maintenance is needed because of the use of salt or brackish water in transporting live fish.

Care should be taken in locating the tanks on the tray of non-articulated trucks. Most operators have used trial and error to find the best tank location. Tanks located too far forward will result in dramatically increased tyre wear, while tanks located too far aft will cause loss of steering authority.

A storage area between the cab and the tanks is useful for storing equipment such as plastic bins and buckets, pumps, hoses, etc. If such items are stored aft of the tanks, it is usually impossible to see if any items come loose or fall off.

### ***Tank Design and Construction***

Tanks used for live fish transport in the US are generally rectangular in shape. Some years ago there was a trend towards using tanks that were elliptical in cross section because these tanks supposedly promoted better circulation of water within the tank and eliminated 'dead water' areas in the corners of rectangular tanks (McCraen and Millard 1978, Piper *et al.* 1982, Carmichael and Tomasso 1988). However, several operators commented that they had found no difference between elliptical and rectangular tanks, or in some cases, that elliptical tanks performed more poorly than rectangular tanks. Rectangular tanks are easier and cheaper to construct and are more space efficient. Consequently, elliptical tanks are now not generally used for transporting live fish.



**Figure 3** Live fish transport truck with equipment storage area behind cab.

The main features of tanks used for transporting live fish (Figure 4) are:

- insulated walls, floor and lid
- internal floor sloping to a central drain
- gate valves fitted internally, and 'Kamlock' or screw fittings externally on drains
- large lids allowing easy access to the tank

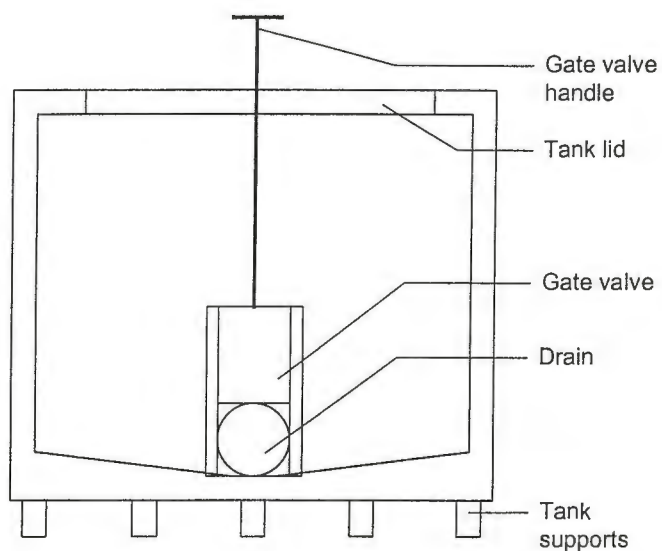

**Figure 4** Diagram showing the major features of live fish transport tank design, including insulated walls, floor sloping to central drain, and location of gate valve for unloading fish.

Tanks can be constructed from fibreglass, aluminium or stainless steel and generally incorporate insulation in the design (McCraren and Millard 1978, Piper *et al.* 1982, Carmichael and Tomasso 1988). Tanks used for salt water should be made from fibreglass, not from metal of any type. Most tanks now in use in the US are constructed from plywood and polyurethane insulation, which is then covered in fibreglass. An example of such construction, as used by a commercial tank manufacturer, is shown in Figure 5. Note the thick layer of insulation and the layer of Coremat® which increases the laminate thickness without adding as much extra weight as would result from a solid fibreglass laminate. One commercial operator who uses aluminium tanks for transporting freshwater fish commented that fish did not transport as well in aluminium tanks as they did in fibreglass tanks, but other operators expressed satisfaction with the performance of aluminium tanks. Food grade ('iso') gelcoat should be used to finish the inside surface of fibreglass tanks. An example of a set of specifications for the construction of fish transportation tanks is included as Appendix 2.

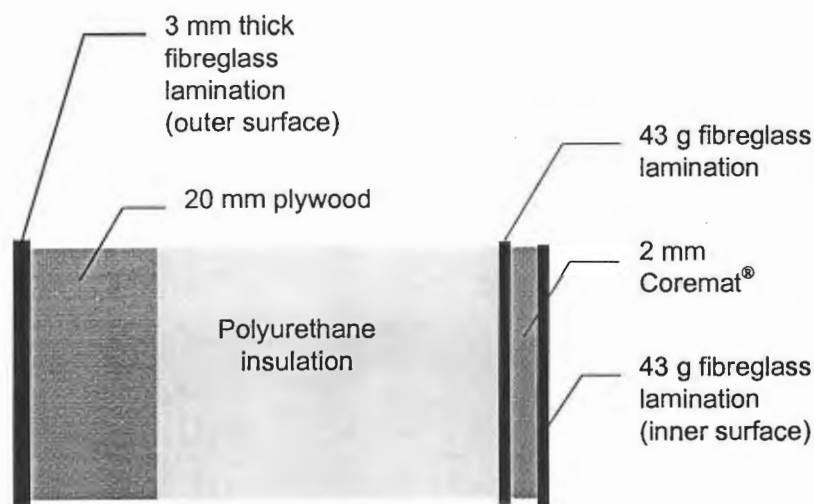

**Figure 5** Details of wall construction of live fish transport tanks made by Peterson Fibreglass Laminates Inc., Shell Lake, Wisconsin, USA. (Not to scale).

Tanks should be constructed with lids that allow easy access to load fish, but that seal firmly to prevent loss of water during transport (Figure 6). Leakage of water from live transport tanks onto passing vehicles is a major cause of complaint for operators in the US. A popular latch for live fish transport tanks in the US is the 'De-Sta-Co' latch (Figure 6).



**Figure 6** (Above) lid of live fish transport tank, showing vent for gas exchange and locking prop. (Below) 'De-Sta-Co' latches in latched (left) and unlatched (right) positions.

Tanks should also be fitted with a gate valve to facilitate unloading the fish (Figure 7). This will allow unloading of the fish straight into holding tanks using PVC piping, without netting or otherwise handling the fish. Holding system design for live fish facilities is discussed in detail in de Guingand *et al.* (1995a). The gate valve(s) should be large enough to admit the largest fish that will be carried. Because gate valves may leak, particularly with wear, a secondary seal should be placed on the outside of the drain (Figure 8). 'Kamlock' or screw fittings are suitable for this purpose, provided that they fully seal the drain.

Surging (the 'sloshing' movement of the water within the tank) can be reduced by filling the tank completely with water, and by subdividing large tanks into smaller units. Surging may damage fish, by hitting them against the tank walls, and may decrease the driver's control of the truck. Surging is also reported to increase the rate of wear of the truck's clutch plates. Provision of baffles in large tanks, or subdivision of large tanks into smaller sections, will assist in reducing problems associated with surging (Piper *et al.* 1982). Most commercial operators in the US use a number of separate tanks on a single truck. This allows fish of different sizes or different species to be carried, or fish to be off-loaded at different sites. For example, Farm Cat Inc. (Arkansas) uses up to 12 individual tanks on a truck. Alternatively, tanks can be constructed with separate compartments incorporated into the tank design.

Tank sizes for food fish species are generally 1 - 1.5 m<sup>3</sup> (1,000 - 1,500 litres). Smaller tanks are used for baitfish.



**Figure 7** Inside view of live fish transport tank showing gate valve, drain trough, and oxygen diffusers constructed from rubber soaker hose.

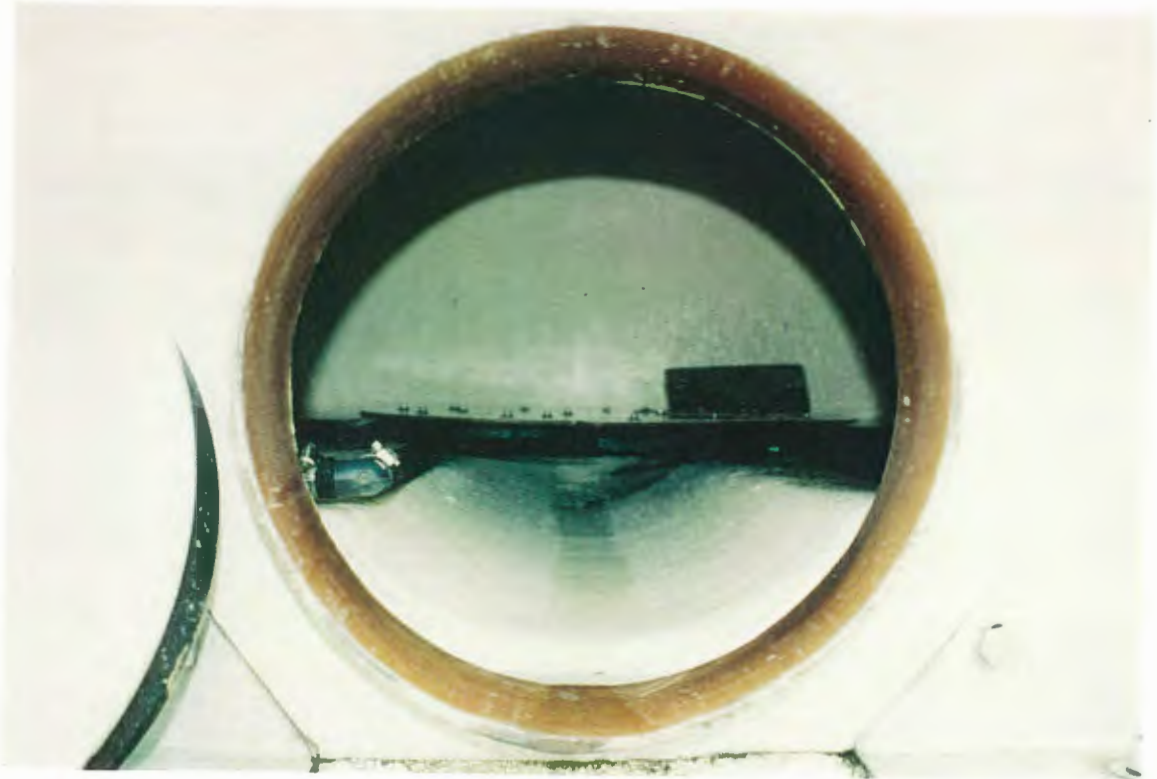

**Figure 8** (Above) View inside live fish transport tank, with gate valve removed, from drain. (Below) External view of tank drain with external plug removed.

Most live fish transport operators do not completely fill their transport tanks, but leave an airspace at the top of the tank. While this causes surge problems during transport, it may also assist in off-gassing excess gases, including carbon dioxide. Most tanks are constructed with a vent in the lid to allow gas exchange with the atmosphere. Operators that did not provide vents to allow gas exchange had problems transporting more sensitive fish species, such as salmonids. These problems were alleviated once vents were fitted to the transport tanks.

Transport tanks should be heavily insulated to allow control of water temperature. Texas Parks and Wildlife Department (TPWD) specify 1½ inch (38 mm) thick closed-cell slab polyurethane foam (c. 16 kg density per cubic metre), for the tank walls, and 4 inch (100 mm) thick foam for the tank floor (Appendix 2). The tanks should be elevated above the truck bed to allow the space between the truck bed and the tank to dry. This will reduce corrosion problems, and reduce water seepage into the tank floor in the event that the exterior fibreglass laminate is damaged.

Fibreglass tanks should be constructed using coloured resin to exclude light from the tank when it is sealed. Transparent or translucent tanks should not be used because the high light levels in such tanks will substantially increase stress levels in the transported fish. Dark coloured tanks generally reduce stress in fish, but lighter colours make it easier to observe the fish in the tank. However, this is only relevant when the tank lid is open, allowing light to penetrate. For fish transport tanks, generally a mid-range blue or green colour is a suitable compromise. Many tanks in commercial use are white, and operators report no problems using such light coloured tanks.

#### **Farm Cat Inc.: a successful US live fish transport operation**

Farm Cat Inc. is a family owned and operated company that specialises in producing food fish (catfish, hybrid striped bass, largemouth bass) and baitfish, and in transporting fish live to markets throughout the US. Farm Cat has a fleet of 9 trucks, including several semi-trailer units. These trucks transport not only Farm Cat's aquacultured products, but are also contracted by other fish producers to transport live fish. From the company's home base in Lonoke, near Little Rock, Arkansas, Farm Cat's trucks transport fish to the east and west coasts of the US, and as far north as northern Canada. This entails trips of up to 5 days duration.

#### ***Preparation Prior to Transport***

Commercial live fish operators list pre-transport preparation of fish as being critical to the success of each trip. In their experience, fish that are prepared properly for transport will travel much better, and arrive in better condition, than those not prepared for transport. The main procedures involved in preparation are starvation prior to loading, and tempering.



Starvation prior to transport is undertaken to allow emptying of the gastro-intestinal tract which decreases the rate of ammonia excretion during transport (Froese 1985, 1988, Piper *et al.* 1982). Unlike mammals, fish can live without food, and remain healthy, for relatively long periods of time (days or weeks). Because the time to empty the gut is related to body weight, large fish must be starved for longer than smaller fish prior to transport (Froese 1985, 1988). Froese (1985) recommends starving fish  $\leq 3$  g for 2 days and fish  $> 3$  g for 3 days prior to transport.

Tempering is also an important part of pre-transport procedures. Fish should not be subjected to rapid changes in water quality, but should be gradually acclimated to different water conditions. Fish should be loaded into the transport tanks filled with water as similar as possible to the water from which they were removed. Once in the transport tanks, the water can be slowly changed to the conditions desired for transport, eg. reducing temperature or adding salt.

### **Water Quality**

Maintaining good water quality is of critical importance in the successful transport of live fish. Poor water quality will cause stress, which will increase the chances of the fish contracting disease, and severe water quality degradation can result in substantial or total mortality. For these reasons, an understanding of water quality and how various parameters affect fish is important in the successful operation of a live fish transport business.

### **Temperature**

Generally, fish are unable to regulate their own body temperature, so the temperature of the surrounding water directly affects their metabolic rate. The metabolic rate of fish is higher at higher temperatures, and thus as temperature increases they will use more oxygen, and produce more carbon dioxide and ammonia than at lower temperatures. Most live fish transport operations use temperature control to lower the metabolic rate of the fish during transport. Most commercial operators use ice to control temperature. Prior to leaving the loading area, blocks of ice are added to lower the temperature to the desired level (usually 20-25°C). For longer trips, additional ice is carried in insulated containers and is added to the transport tanks as necessary to maintain the desired temperature. Some larger fish transport units are fitted with integrated refrigerative cooling units (McCraren and Millard 1978) (Figure 9).

Care should be taken when using ice to lower the temperature of the transport water. Commercially available ice may be made from treated water and may contain substantial amounts of chlorine, which is lethal to fish. The addition of even moderate amounts of freshwater ice to a transport tank may drastically change the salinity of the water, causing additional stress for the fish.

If cooling units are used, any material in contact with the transport water should be inert, eg. plastic or titanium. Stainless steel may also be suitable for cooling units, although personal experience with stainless steel in cooling units exposed to sea water has been that its life is limited to only a few months.

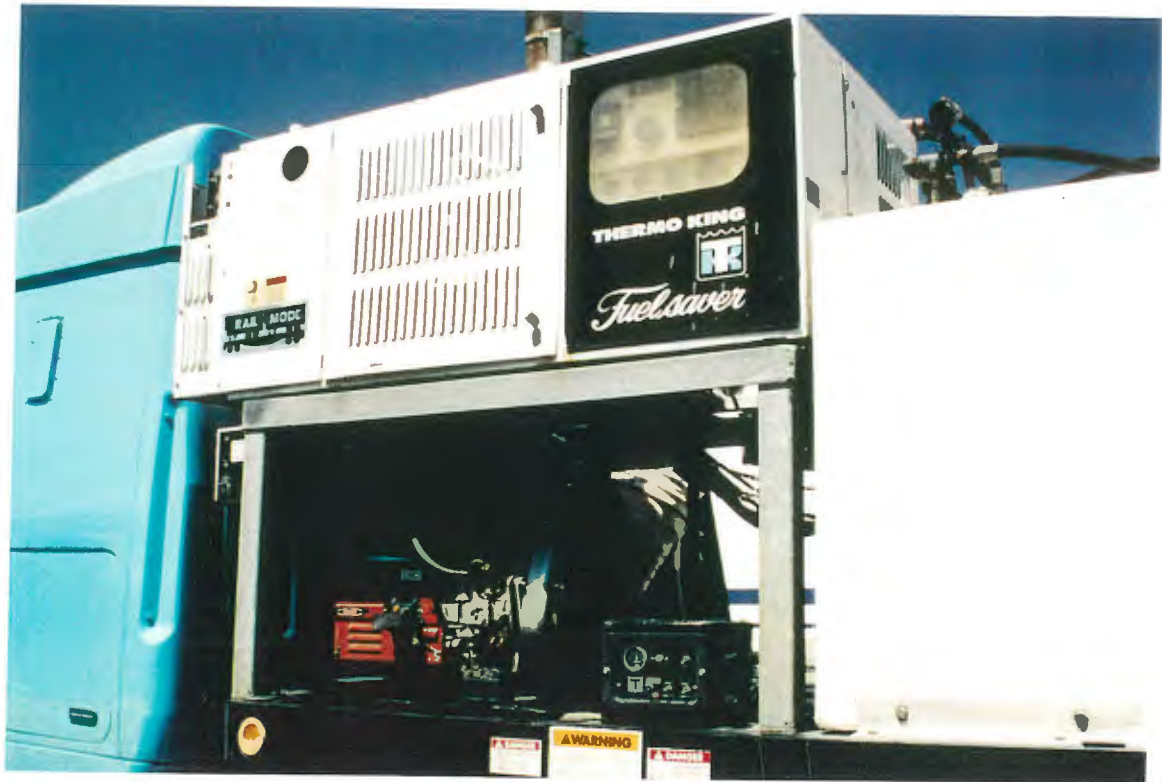

**Figure 9** (Above) Refrigerative cooling system fitted to live fish transport truck. (Below) Cooling coils of refrigerative system in live fish transport tank. Note cloud of fine bubbles from oxygen diffuser. White tube at left is an agitator, with black plastic mesh screen fitted to protect small fish from agitator turbulence.

## **Salinity**

The salinity of freshwater is 0 ppt and the salinity of full seawater is about 36 ppt. Fish should be transported at about the same salinity that they normally inhabit. However, freshwater fish should be transported in water to which about 5-10 grams of salt has been added for each litre of water (equivalent to 5-10 ppt). The addition of small amounts of salt to freshwater helps reduce stress, probably by reducing the osmotic load on freshwater fish (McCraren and Millard 1978). Similarly, a slight reduction in the salinity of sea water for the transport of salt water (to 32-33 ppt) species may be beneficial. Euryhaline species, such as farmed barramundi, should be transported at about the salinity at which they were grown.

Salinity is most easily measured using a salinity meter. Small portable salinity meters are readily available and are reliable if treated properly. Hydrometers are not accurate enough for use in live fish transport applications.

## **Oxygen**

Fish use oxygen in the water for respiration. Consequently, oxygen must be provided constantly to fish during transport to make up for the loss of oxygen due to respiration. At high fish densities and without supplemental oxygen, fish may last only minutes before all the oxygen in the water is used and fish begin dying.

Dissolved oxygen (the concentration of oxygen dissolved in the water) is measured using a dissolved oxygen meter. These meters can be expensive, but are essential for any operation involved in road transport of live fish. Most meters measure both the actual concentration of oxygen in the water (in ppm or mg/l) and the relative amount of oxygen in the water (percent saturation). Some live fish transport units are fitted with dissolved oxygen sensors in each tank, and a readout unit in the cab to enable dissolved oxygen levels to be monitored at all times.

Saturation is a measure of the maximum amount of oxygen that water will hold under certain conditions. Oxygen saturation is a function of temperature, salinity and pressure (altitude) (Boyd 1990). Oxygen solubility decreases with increasing temperature, increasing salinity (Figure 10) and increasing altitude. (Oxygen saturation values for water at various combinations of temperature and salinity are listed in Appendix 3). Aeration of water (ie. by pumping air through water) will provide dissolved oxygen concentrations up to the saturation value for that temperature and salinity, but no higher. Pumping oxygen through water will allow supersaturation, ie. dissolved oxygen concentrations in excess of the saturation value. Supersaturation may be detrimental to some fish species. In general, the dissolved oxygen level should be kept as closely as possible to 100% saturation. Dissolved oxygen should not drop below 50% saturation, nor should it exceed 150% saturation. Commercial fish transport operators recommend that dissolved oxygen levels in the tanks be maintained at 8 - 11 mg/l.

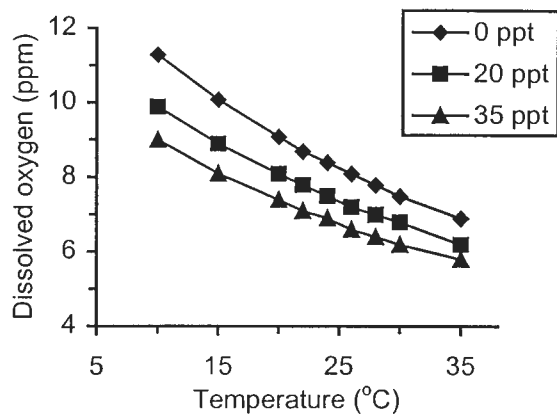

**Figure 10** Saturation values of dissolved oxygen in water at 3 different salinities (0, 20 and 35 ppt) and a range of temperatures (Boyd 1990).

An adequate level of dissolved oxygen in transport tanks is maintained by pumping oxygen into the transport water. Provision of adequate amounts of oxygen is particularly important in transporting fish long distances. Fish that have been captured and loaded into transport tanks are severely stressed. One manifestation of this stress is that their metabolic rate increases, and this causes dramatically increased oxygen consumption.

Aeration alone, using centrifugal air blowers, is generally not used in road transport of live fish. Aeration will not cope with the high oxygen demand of fish transported at high density; only the provision of oxygen will enable adequate dissolved oxygen levels to be maintained. Another disadvantage to using aeration is that the heat developed by the blowers increases water temperature significantly, leading to an increased metabolic rate of the transported fish, and consequent increases in oxygen usage and carbon dioxide production. In addition, the high volumes of air required result in severe turbulence in the tanks which may cause physical damage to the fish.

Small-scale fish transporters, such as those used to transport broodfish or fingerlings for restocking, use bottled oxygen (Figure 1). These transporters are used over relatively short distances, up to 12 hours from their base of operations. Larger transporters, which may be away from base for several days or even weeks, use liquid oxygen (Figure 13). Liquid oxygen has several advantages over bottled oxygen:

- liquid oxygen is more dense and thus takes up less space on the truck
- liquid oxygen is cold and its provision to tanks assists in lowering the temperature of the transport water
- liquid oxygen is cheaper than an equivalent amount of bottled oxygen gas.

Most large fish transport operations have a large storage container of liquid oxygen at their base, which is used to fill the tanks on the trucks as required (Figure 13). The storage container is in turn filled by the local supplier, usually once per week. Operators suggest that liquid oxygen tanks on the trucks should be topped up after each trip, rather than being left until almost empty before being refilled. On at least one occasion, the latter approach has resulted in the loss of a load of fish when the tank wasn't refilled and

oxygen ran out during the trip. Like other liquefied gases, liquid oxygen will vaporise at ambient temperatures. Unlike bottled oxygen gas, unused containers of liquid oxygen will eventually empty as the oxygen vaporises into the atmosphere. One operator estimated the loss of liquid oxygen in this manner at about 2% per day.

For bottled oxygen, industrial grade oxygen, rather than the more expensive medical grade, is adequate for fish transportation. The flow of oxygen is regulated using commercially available flow regulators, but a more accurate and reliable medical flow gauge should also be fitted (Figure 14). This allows finer control of the oxygen flow rate than the standard regulator, thus preventing wastage of oxygen which can result in premature exhaustion of the oxygen supply. Typically, live fish transport tanks are fitted with one or more liquid oxygen cylinders. Oxygen from this tank is piped to the fish tanks, each of which is fitted with an individual flow gauge to allow fine control of the oxygen supply to that tank (Figure 14). If individual diffusers are fitted, a flow control should be fitted to each diffuser, because individual diffusers differ substantially in porosity and thus require individual adjustment.

Many live fish transport units have the main oxygen supply line running down the length of the tank, and terminating in a pressure gauge that is located near the rear window so that the driver can monitor oxygen pressure by checking the gauge in the rear view mirror. More sophisticated units have a pressure sensor and alarm fitted to the oxygen supply, and dissolved oxygen sensors in each tank with a display unit located in the cab of the truck (Figure 15).

Oxygen concentration in transport tanks should be relatively high before the fish are placed in the tank. For the first ½ hour to 1 hour after loading, the fish will use

*The effect of bubble size on oxygen diffusion*

A volume of small oxygen bubbles has a larger surface area than an equivalent volume of larger bubbles, and thus will transfer oxygen to water more efficiently. For example, a 1 mm diameter bubble has a surface area of 3 mm<sup>2</sup> and a volume of 0.5 mm<sup>3</sup> of oxygen. A 3 mm bubble has a surface area of 28 mm<sup>2</sup> and a volume of 14 mm<sup>3</sup>. Twenty eight 1 mm diameter bubbles contain as much oxygen as one 3 mm bubble, but have a surface area of 88 mm<sup>2</sup>, which is 3 times the surface area of the 3 mm bubble. The larger surface area of the smaller bubbles means that potentially 3 times as much oxygen can be added to the water using 1 mm diameter bubbles than with the equivalent volume of 3 mm diameter bubbles.

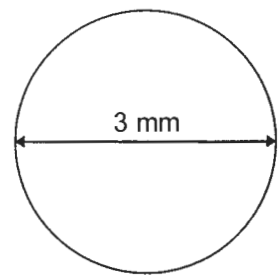

Surface area: 28 mm<sup>2</sup>  
Volume: 14 mm<sup>3</sup>

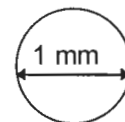

Surface area: 3 mm<sup>2</sup>  
Volume: 0.5 mm<sup>3</sup>

**Figure 11** Surface area and volume for 1 and 3 mm diameter oxygen bubbles.

substantially more oxygen than they will during the rest of the journey (Johnson 1979). This dramatic increase in oxygen consumption usually results in a drop in oxygen concentration in the transport tank immediately after loading (Figure 12). If this higher rate of oxygen consumption is not taken into account, and the oxygen flow increased to compensate, this drop in oxygen concentration may prove lethal to the fish (Johnson 1979).

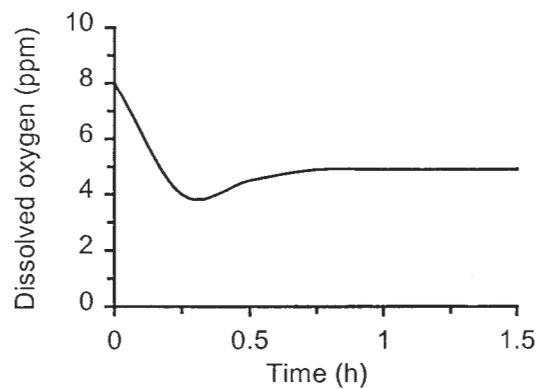

**Figure 12** Dissolved oxygen concentration in transport tank after loading fish (Johnson 1979).

### Carbon dioxide

Some live fish transport units incorporate agitators (usually 12V units) in the transport tanks to blow off carbon dioxide which is produced as a product of respiration (Piper *et al.* 1982, Carmichael and Tomasso 1988). Carbon dioxide is toxic at high concentrations, and at low concentrations will substantially reduce the pH of the transport water (McCraren and Millard 1978). Low pH contributes to fish stress and will reduce the ability of the fish to take up oxygen, even when dissolved oxygen levels are high (McCraren and Millard 1978). Consequently, the removal of carbon dioxide is an important component of reducing the stress of fish transported live. Agitators also help to off-gas excess oxygen, thus precluding any problems that may result from extremely high dissolved oxygen levels (supersaturation). When agitators are used (Figure 14), some operators use them constantly, while others switch them on intermittently, eg. for 10 minutes every hour. It is important that the transport tanks are vented to the outside atmosphere to allow gas exchange with the atmosphere (Piper *et al.* 1982, Carmichael and Tomasso 1988).

Many commercial live fish transport operators do not use agitators. Because most tanks are not filled completely, some off-gassing of carbon dioxide may occur in these tanks as the water surges and is splashed around inside the tank. However, some destinations reported receiving fish in relatively poor condition due to high carbon dioxide levels in tanks that were not fitted with mechanical agitators or vents.

Agitators may exhaust or physically damage small fish and fingerlings because of the high water velocities they produce in the tank. To better control the amount of water movement provided by agitators, rheostats can be used to vary the speed of individual agitators. Alternatively, the agitators can be operated intermittently rather than constantly to avoid exhausting the fish. Because of the use of salt even when transporting freshwater fish, operators recommend using agitators designed for use in saltwater.

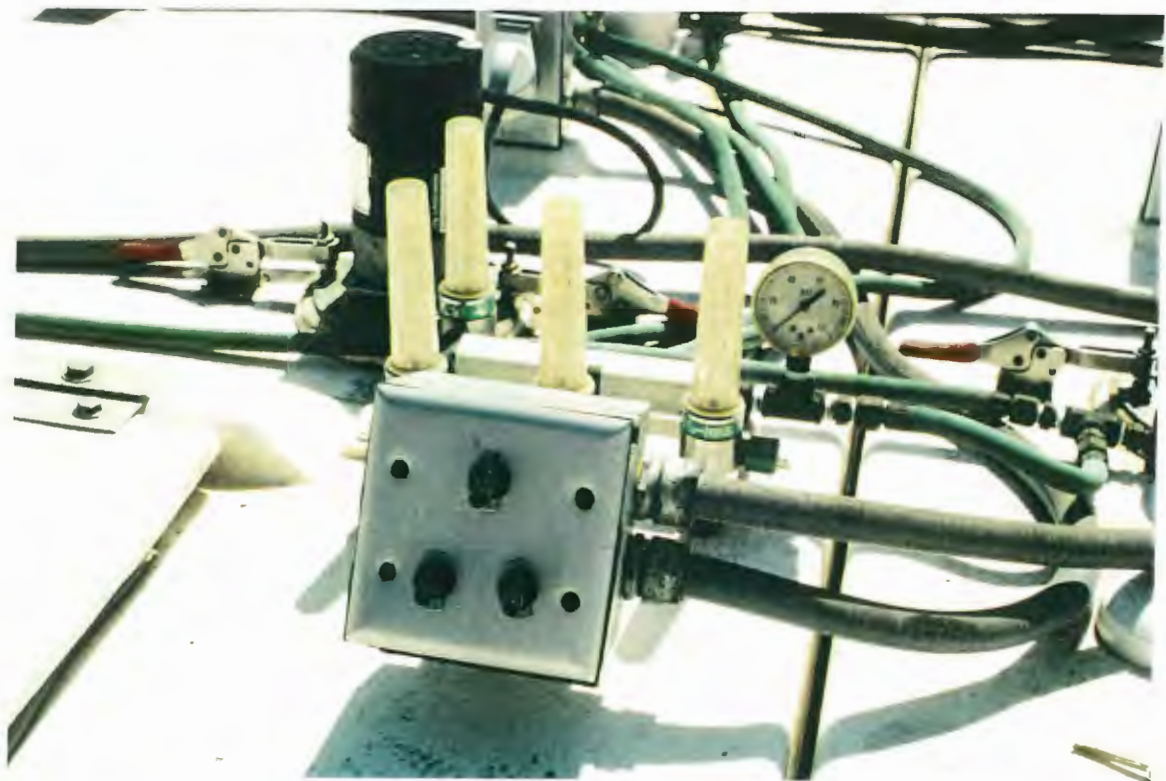

Figure 13 (Above) Liquid oxygen tank fitted to live fish transport truck. (Below) Liquid oxygen storage tank.



**Figure 14** (Above) Controls for live fish transport tank, including: individual flow controls for each air diffuser, oxygen supply system pressure gauge, individual switches for agitators. Note agitator held in place with 'De-Sta-Co' latches, plugged into waterproof 12V power supply. (Below) Oxygen supply system pressure gauge, located to be visible in driver's rear view mirror.





**Figure 15** (Above) Cab of live fish transport truck showing display unit for dissolved oxygen sensors fitted to tanks, and low oxygen pressure alarm. (Below) Live fish transport tanks showing oxygen supply system and individual flow controls for each diffuser, agitators (3 per tank) and switches.

## pH

pH is a measure of the acidity or alkalinity of water. A neutral pH is 7.0; lower pH values indicate acid conditions and higher pH values indicate alkaline conditions.

The pH of salt water is usually about 8.0 and the pH of freshwater is about 7.0. Because of the large buffering capacity of salt water, pH in salt or brackish water generally varies less than in freshwater. pH may drop dramatically in fish transport tanks, if carbon dioxide is allowed to accumulate in the water. Low pH causes a range of physiological problems in fish, but primarily affects the fishes' ability to utilise oxygen for respiration. Thus at low pH and high carbon dioxide concentrations, fish may suffer severe respiratory stress even though dissolved oxygen levels are high.

The use of agitators to remove carbon dioxide, and the provision of vents in the tanks to allow excess gases to escape to the atmosphere, will prevent drastic changes in the pH of the transport water.

## Ammonia

Ammonia is the main nitrogenous compound excreted by fish and will accumulate during transport. Ammonia has two forms, unionised ammonia ( $\text{NH}_3$ ) which is toxic to fish and ionised ammonia ( $\text{NH}_4^+$ ) which is effectively non-toxic. The relative proportions of each form depend primarily on water temperature and pH. The higher the pH and temperature, the more ammonia will be present in the toxic  $\text{NH}_3$  form (Boyd 1990). Most test kits measure total ammonia, ie. the combined total of  $\text{NH}_3$  and  $\text{NH}_4^+$ . The proportion of  $\text{NH}_3$  must then be derived from published tables of ammonia dissociation (Appendix 4) to determine the concentration of the toxic form in the water.

Ammonia is transformed to nitrite and nitrate during the process of nitrification which is undertaken by bacteria under aerobic conditions (Spotte 1970), as occurs in biological filters (de Guingand *et al.* 1995b). Nitrite is toxic to fish at very high concentrations, but nitrate is effectively not toxic. None of these nitrogenous products is of particular concern during fish transport. High levels of ammonia will adversely affect fish health and growth, but only over a period of time longer than that typically used for fish transport.

Biological filtration is not used in road transport applications, because of the difficulty of properly maintaining biological filters under these conditions. Biological filters must be maintained with a constant load of ammonia in order for them to function efficiently (de Guingand *et al.* 1995b), and such maintenance is usually incompatible with their use in road transport applications. In addition, the production of ammonia is rarely the limiting factor in transport of fish, so its removal is usually not cost-effective.

A more practical technique for reducing ammonia accumulation during transport is to starve the fish for several days prior to transport (see 'Starvation prior to transport' discussion). In addition, partial water changes during the transport period will lower ammonia and help alleviate other adverse water quality parameters.

## Measuring Water Quality Parameters

Different water quality parameters are measured using different devices. Dissolved oxygen, salinity and pH are measured using specialised meters. Several companies make multi-purpose meters that allow the operator to measure several variables with one instrument. Such multi-parameter meters are easier to handle than several individual meters, and often provide a cost saving over the purchase of separate meters. The main disadvantage of multi-parameter meters is that, should the meter break down, the operator is left with no means of testing any water quality parameters.

For road transport of live fish, the following test equipment is recommended:

1. A good quality dissolved oxygen (DO) meter.
2. A pH meter or colourimetric test kit.
3. A colourimetric test kit for carbon dioxide (CO<sub>2</sub>).
4. A colourimetric test kit for ammonia (NH<sub>3</sub> / NH<sub>4</sub><sup>+</sup>) or ammonia-nitrogen (NH<sub>3</sub>-N / NH<sub>4</sub><sup>+</sup>-N).
5. A salinity meter.

All water quality meters should be maintained according to the manufacturers instructions. Dissolved oxygen meters are particularly sensitive and require regular maintenance, including frequent replacement of probe membranes, if they are to remain accurate. All probes should be rinsed with fresh water and stored carefully after each use. pH, carbon dioxide, ammonia, nitrite, and nitrate can be tested with acceptable accuracy using colourimetric test kits designed for aquarium use. The reagents in these kits have a limited life span and should be regularly replaced if they are not used up.

Some test kits measure ammonia, nitrite, and nitrate (NH<sub>3</sub>, NO<sub>2</sub>, and NO<sub>3</sub>) as the nitrogen equivalent forms (NH<sub>3</sub>-N, NO<sub>2</sub>-N, and NO<sub>3</sub>-N). This measurement can be converted to the standard form using the following relationships:

$$1 \text{ mg/l NH}_3\text{-N} = 1.2 \text{ mg/l NH}_3$$

$$1 \text{ mg/l NO}_2\text{-N} = 3.3 \text{ mg/l NO}_2$$

$$1 \text{ mg/l NO}_3\text{-N} = 4.4 \text{ mg/l NO}_3$$

The Austasia Aquaculture Trade Directory (see 'Further Information' section) provides a list of manufacturers and suppliers of water quality testing equipment.

## Anaesthetics and Chemical Additives

There are currently no chemicals registered for use on food fish in Australia. Technically, this means that no chemicals, including anaesthetics and antibiotics, can be used on fish destined for human consumption. The National Registration Authority (NRA) has produced a preliminary list of chemicals and probable restrictions that will be applied once the registration process is completed. Under this protocol, the use of many chemicals, including anaesthetics, will involve extensive with-holding periods following treatment. This will make the use of such chemicals impractical for use in transporting fish live.

Buffers will most likely not have such restrictive procedures associated with their use. Buffers, as the name suggest, reduce pH fluctuation by buffering the water. A buffer commonly used for fish transport is 'tris' buffer (tris-hydroxymethyl-amino-methane). 'Tris' is available in a range of pH values for use on freshwater and marine fish. Levels of 1.3-2.6 g/l are recommended for fish transport applications (McCraen and Millard 1978). However, 'tris' buffer is expensive and because of this, is not generally used in road transport of live fish.

As noted in the discussion on salinity, above, the addition of salt is widely used for transporting freshwater fish.

Antifoaming agents are generally not used. One operator noted that adding antifoaming agents to the transport tanks led to an immediate and drastic decrease in dissolved oxygen levels, often by as much as 50%.

### *Loading Density*

Precise loading densities for every road transport system are difficult to derive, due to the substantial differences between different operations. In addition, the carrying capacity of a particular unit will depend on the efficiency of the aeration system, duration of transport, water temperature, fish size, and fish species (Piper *et al.* 1982). Most of the published information that is available is limited to food fish and bait fish species that are transported in the US, and this is of limited application to transporting Australian fish species. The most commonly transported warmwater foodfish in the US are catfish and tilapia, neither of which is a good model for Australian fish species because of the extreme hardiness and tolerance to adverse water quality of both catfish and tilapia.

There are several important factors that must be considered when considering loading densities.

- Per unit weight, fewer small fish can be carried than large fish (Table 1, Table 2). Smaller fish consume more oxygen, respire more carbon dioxide, and excrete more ammonia than an equivalent weight of larger fish (Piper *et al.* 1982, Froese 1985). For example, catfish with an average weight of 455 g can be transported at 0.76 kg of fish per litre of water (for 8 hours at 18°C), but catfish with an average weight of 114 g can be transported at only 0.60 kg per litre, and 0.9 g fingerlings can be transported at only 0.21 kg per litre (McCraen and Millard 1978).
- Longer transport requires reduced loading density (Table 1). Again using catfish as an example, fish with an average weight of 455 g can be transported at a density of 0.76 kg of fish per litre of water for 8 hours, but when the transport duration is increased to 12 hours density is reduced to 0.67 kg per litre, and is further reduced to 0.58 kg per litre for 16 hours of transport (McCraen and Millard 1978).
- Temperature also affects loading density. Decreasing water temperature will reduce fish metabolism, decreasing the rate of oxygen consumption and the rate of carbon dioxide excretion, and also reducing the rate of ammonia accumulation. As a general rule, for each 1°C decrease in temperature, the load can be increased by about 10% (Piper *et al.* 1982). Obviously, some knowledge of the temperature limits of the species being transported is required to ensure that the temperature remains above the minimal thermal tolerance for that species.

US operators routinely transport catfish at water:fish ratios of around 1:1 (750 kg of fish in a 1500 litre tank).

For Australian operators, a good strategy is to start at much lower densities than those listed here (for example, about ¼ of these densities) and increase the density gradually as the operators become more experienced. It is doubtful that any Australian fish species can be transported at the extremely high densities at which catfish and tilapia are transported in the US.

**Table 1** Stocking rate (kilograms of fish per litre of transport water) for catfish transported at 18°C for 8 - 16 hours (McCraren and Millard 1978).

Average weight of fish (g)	Transit period (hours)		
	8	12	16
455	0.76	0.67	0.58
228	0.71	0.58	0.41
114	0.60	0.49	0.35
9.1	0.41	0.30	0.25
3.6	0.35	0.26	0.22
1.8	0.26	0.21	0.18
0.9	0.21	0.20	0.15
0.5	0.15	0.12	0.08
0.05	0.02	0.02	0.02

**Table 2** Stocking rate (kilograms of fish per litre of transport water) for live northern pike and walleye transported for 8 hours at 13-18°C (Piper *et al.* 1982).

Fish weight	Size (mm)	Stocking rate (kg/l)
7.6	76	0.16
0.9	51	0.08
0.5	25	0.07

### **Acclimation**

Sudden changes in water quality, particularly temperature, salinity, and pH, may stress fish. Consequently, care should be taken to ensure that variations in water quality are minimised when fish are transferred from one tank to another. Minimal handling will reduce fish stress, and one innovative loading system is illustrated in Figure 16.

After transport, fish should be acclimated slowly to conditions in their new environment because physicochemical conditions in the transport medium and in the receiving environment may differ substantially. New water should be added to the transport containers in small amounts over a period of about 30 minutes, until the final volume exceeds the initial quantity by 2-3 times (Froese 1985). Only when this acclimation is complete should the fish be introduced to their new holding tanks.



**Figure 16** Handling free loading system in use at Kalama State Fish Hatchery, Washington. Fish are loaded from an overhead tank via a flexible coupling (above) that connects to a hatch on the top of the transport tank (below). When the valves on the truck tank are opened, the water and fish in the overhead tank drain into the truck tank.

### **Further Information**

Much of the equipment required for live fish transport is similar to that used for aquaculture, and can be obtained from suppliers involved in the aquaculture industry. A good source of information on aquaculture suppliers is 'Austasia Aquaculture', a bimonthly magazine that covers aquaculture in Australia, New Zealand and Asia. The publisher of this magazine also produces an annual Aquaculture Trade Directory which is a useful reference for aquaculture equipment and services, including many items of relevance to live fish transport. For further details, contact Austasia Aquaculture Magazine, PO Box 279, Sandy Bay, Tasmania 7005.

The author of this report has several equipment catalogs from US suppliers. For further details, contact Mike Rimmer at Northern Fisheries Centre, PO Box 5396 Cairns, Queensland, 4870; phone: (070) 529809, fax: (070) 351401, e-mail: rimmerm@dpi.qld.gov.au

### **References**

- Boyd, C.E. (1990). Water Quality in Ponds for Aquaculture. Auburn University, Alabama. 482 pp.
- Carmichael, G.J. and Tomasso, J.R. (1988). Survey of fish transportation equipment and techniques. *Progressive Fish-Culturist* 50, 155-159.
- Froese, R. (1985). Improved fish transport in plastic bags. *ICLARM Newsletter* 8(4), 8-9.
- Froese, R. (1988). Relationship between body weight and loading densities in fish transport using the plastic bag method. *Aquaculture and Fisheries Management* 19, 275-281.
- de Guingand, P., Rimmer, M., Brouwer, R. and Meikle, G. (1995a). Live fish 'on hold' - system design is the key to success. *Australian Fisheries* 54(2), 14-18.
- de Guingand, P., Rimmer, M. and O'Brien, J. (1995b). Recirculating system design for live fish facilities. *Professional Fisherman*, October 1995, in press.
- Johnson, S.K. (1979). Transport of live fish. In: Davis, J.T. (ed.). *Proceedings of 1979 Fish Farming Conference and Annual Convention, Catfish Farmers of Texas, 17-19 January 1979*. Texas Agricultural Extension Service, Texas Agricultural Experiment Station, College of Agriculture, The Texas A&M University System.
- McCrary, J.P. and Millard, J.L. (1978). III. Transportation of warmwater fishes. In: *Manual of Fish Culture*. Section G. Fish Transportation. US Fish and Wildlife Service, Washington, D.C. pp. 43-88.

Merrick, J.R. and Lambert, C.N. (1991). The Yabby, Marron and Red Claw - Production and Marketing. J.R. Merrick, Artarmon, N.S.W. 180 pp.

Piper, R.G., McElwain, I.B., Orme, L.E., McCraren, J.P., Fowler, L.G. and Leonard, J.R. (1982). Fish Hatchery Management. American Fisheries Society, Bethesda, MD. 517 pp.

Rimmer, M., Paterson, B. and de Guingand, P. (1994). A guide to live fish capture and handling. Australian Fisheries 53(6), 19-21.

Spotte, S. (1970). Fish and Invertebrate Culture - Water Management in Closed Systems. John Wiley and Sons, New York.



# **SECTION 3**

## ***POST-TRANSPORT MAINTENANCE***

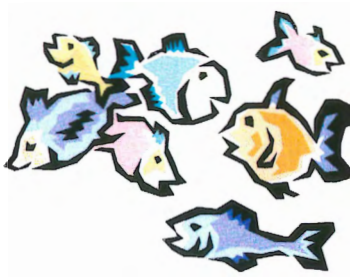

### ***CONTENTS***

#### **Post-transport maintenance of live finfish**

A. Thomas, I.G. Anderson and D. Walters

# Post-transport maintenance of live finfish

A. Thomas<sup>1</sup>, I.G. Anderson<sup>1</sup> and D. Walters<sup>2</sup>

1 Queensland Department of Primary Industries, Oonoonba Veterinary Laboratory, PO Box 1085, Townsville, Queensland 4810.

2 Fish Health Unit, Tasmanian Department of Primary Industries and Fisheries, PO Box 46, Kings Meadows, Tasmania 7249.

## **Abstract**

The health of transported fish was evaluated with respect to both fish health (bacterial and ectoparasite levels) and levels of potential human health pathogens (*Salmonellae* and *Vibrio parahaemolyticus*) for barramundi (*Lates calcarifer*) and banded morwong (*Cheilodactylus spectabilis*). Bacterial levels were low for both species immediately following transport, and 1 week after transport. All samples were well within the required criteria for human consumption. Numbers of ectoparasites varied depending on the source of the fish, but in all cases this was insufficient to cause any fish health problems during the post-transport holding period.

## **Introduction**

Following the transportation stage, live fish are held in tanks at the wholesale or retail facility (Figure 1). Because there has been considerable expense invested in getting the fish to the market alive, it is essential that the fish remain alive long enough to be sold. Although this period may vary somewhat between operators, after discussions with industry representatives, we nominated 1 week as a reasonable length of time that fish would be held in live fish markets. The fish must not only be alive at this final stage, but they must appear healthy and in good condition to bring premium prices.

Unfortunately, any live transport procedure is inherently stressful, and stress is the major predisposing factor in causing disease in fishes. Thus, it can be expected that transported fish will be subject to a number of health problems during this holding period. The component of the project discussed in this chapter investigated fish health following transport. The objective of this section of the project was to determine whether transport of live fish promoted the proliferation of parasites or bacteria that would affect fish health in the receiving facility, and whether there was proliferation of bacteria that were potential human health pathogens.



**Figure 1** Live fish holding tanks in Hong Kong. These tanks typically have high stocking densities and hold a variety of fish species.

Aspects of fish health examined were:

1. Bacterial levels: this provides an indication of whether total bacterial levels increase in holding facilities after transport.
2. Salmonellae: levels of Salmonellae were tested to determine the safety of the final product for human consumption.
3. *Vibrio parahaemolyticus*: samples were tested for proliferation of *V. parahaemolyticus*, a potential human pathogen.
4. Ectoparasites: ectoparasites are a major cause of fish mortality in marine holding systems, so the levels of ectoparasites on the fish were recorded to determine whether this was likely to be an important limiting factor in holding fish after transport.

### **Materials and Methods**

Where applicable, examinations were carried out according to Australian Standard AS 1766 (Food Microbiology) to enable standardisation with other seafood products. Examinations were undertaken using barramundi (*Lates calcarifer*) for the Queensland component of the project, and banded morwong and banded morwong (*Cheilodactylus spectabilis*) for the Tasmanian component.

#### **Queensland**

In Experiment 1, barramundi 500 g to 1 kg in weight were held at NFC in flow-through sea water tanks prior to packing and transport. In Experiment 2, barramundi c. 500 g in weight were harvested from a commercial barramundi farm, packed and transported immediately. Fish were packed in plastic bags in standard 15 kg capacity EPS seafood boxes according to Australian air freight regulations, at water:fish ratios of 2:1 to 3:1. Fish were sent by air freight to Oonoonba Veterinary Laboratory (OVL), Townsville. At OVL, one group of fish was sampled immediately after transport, and a second group of fish was held for an additional week following transport, and then sampled.

#### **Tasmania**

Samples of banded morwong were sent to the Tasmanian Department of Primary Industries' Mt. Pleasant Laboratories (Food and Environmental Microbiology section). Samples were of three different groups:

1. Control fish - these fish were brought up to the factory and held in a recirculating system for 7 days and then sacrificed and sent on ice to the above laboratories (3 fish)
2. Transport fish - these fish were subject to an 18 hour transport trial, sacrificed and sent on ice to the above laboratories.
3. Post-transport fish - these fish had been subject to an 18 hour transport trial, kept alive in the recirculating system at Southern Ocean Products for 7 days, sacrificed and then sent on ice to the above laboratories.

Banded morwong samples for analysis were cut from whole fish, skin removed, and tissue homogenised and diluted by  $10^{-1}$ . This procedure was undertaken at Mt. Pleasant Laboratories, Launceston.

## Testing Procedures

### *Microbiological Examination*

Microbiological examinations were made for

1. Standard plate count
2. Salmonellae
3. *Vibrio parahaemolyticus*

to Australian Standard (AS) 1766.3.5 (1983) Food Microbiology.

### *Preparation of Test Samples (AS 1766.3.5 - part 8)*

The size of the barramundi to be examined in the project ( $> 15\text{cm}$  but  $\leq 30\text{cm}$  total length) required a modified '8.7.a excised surface' procedure. Five live barramundi from each batch were euthanased by transection of the spinal cord immediately caudal to the cranium, then placed on clean paper. To obtain sufficient sample material (55 g for standard plate count (SPC), 25 g for Salmonellae and 25 g for *V. parahaemolyticus*) the skin from both sides of the caudal peduncle and dorsal area of the body were removed. This included 2-5mm of underlying tissue. Appropriate amounts were cut up into small pieces using sterile forceps and scissors and placed in a sterile, tared blender.

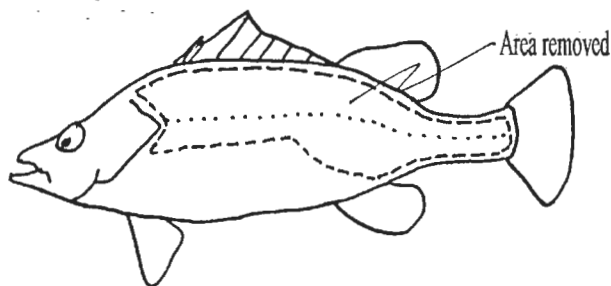

### *Standard Plate Count (AS1766.1.4 - 1991 and AS1766.2.1 - 1991)*

Fifty-five g of sample material was added to 500 mL of 0.1% peptone solution (1766.3.5 - part 8.7), and the mixture blended for 60 seconds at high speed. Dilutions were prepared through 9mL 0.1% peptone solution (1766.1.2) to get 5 dilutions (including the first dilution), then 0.1 mL of each dilution was transferred to two plates of plate count agar and immediately spread. The plates were incubated at 25°C for 72 hours then counted.

### *Salmonellae (AS1766.2.5 - 1991)*

Twenty five g of sample material was added to 225mL of buffered peptone water (BPW) (1%), and blended for 60 seconds at high speed. The pH of the solution was adjusted to 7.0, and the solution was incubated at 37°C for 16-20 h. Two tubes of BPW were inoculated with the reference cultures.

One mL of the pre-enrichment culture was inoculated into 10mL of mannitol selenite cystine broth and incubated at 37°C for 18-24 h. 0.1 mL of the pre-enrichment culture was inoculated into 10 mL of Rappaport-Vassiliadis (RV) medium and incubated at 42°C for 18-24 h. Using a 5mm inoculating loop, each culture of enrichment medium was transferred and streaked onto dried XLD agar and bismuth sulfite agar plates, and the plates incubated at 37°C. The XLD plates were examined after 18-24 h incubation and the bismuth sulfite plates were examined after 18-24 hours incubation and again after 48 h incubation and any suspect

colonies identified.

*Vibrio parahaemolyticus* (ASI766.2.9 - 1991 and ASI766.1.6 - 1991) - most probable number

Twenty-five g of sample was added to 225 ml of 0.1% peptone solution with 30g/L NaCl, and the solution blended for 60 seconds at high speed. The solution was diluted through 9ml 0.1% peptone solution with 30g/l NaCl to get three dilutions (including the first dilution). Primary enrichment was undertaken by inoculating 1mL of each dilution into three tubes containing 10 mL of alkaline peptone water (APW). A tube of APW was inoculated with the reference culture. Tests and control tube were incubated at 37°C for 6 to 8 h. Secondary enrichment was undertaken after this time by transferring 1mL from each tube to a fresh tube of APW. A loopful of each primary enrichment culture was streaked onto a plate of thiosulfate citrate bile-salts sucrose (TCBS) agar. The secondary enrichment tubes and the TCBS agar plates were incubated at 37°C for 18 h. A loopful of each secondary enrichment was streaked onto TCBS plates and incubated at 37°C for 18 h. At the end of their respective incubation periods, the plates were examined for typical colonies of *V. parahaemolyticus*.

For confirmation of the presence of *V. parahaemolyticus*, follow the procedure outlined in 1766.2.9 part 6.2.

*Ectoparasite Examination*

One cm<sup>2</sup> templates cut from heavy aluminium foil were used to define the sampling area. Mucus and superficial epidermal cells were gently scraped from within the sample area from three sites on the left side of each fish:

1. just below the dorsal fin, in line with the cranial edge of the dorsal fin,
2. just below the lateral line, in line with the cranial edge of the dorsal fin,
3. on the medial ventral surface, just in front of the pelvic fins.

The base of the pectoral fin was also sampled to help confirm the absence or presence of ectoparasites if the other sample sites have no parasites. The mucus and cells from each site were mounted on a glass microscope slide, a drop of water the fish were swimming in was added, then mixed and covered by a 22 x 22mm glass cover slip. The entire area under the cover slip was examined at 100x magnification. Higher magnification was used to presumptively identify any parasite. The number of parasites was recorded (or scored e.g. +, ++ +++, +++++ if there were too many to count individually) for each 1 cm<sup>2</sup> site.

For examination of the gills, the left, outer most (first) gill arch was removed by cutting the attachment points. Ten gill filaments were cut from the centre of the arch and wet mounted on a glass microscope slide. The gill filaments were examined along their full length under 100x magnification and the number of parasites counted (or scored, using the scale listed above). The gill arch was turned over, the filaments along the entire length were gently scraped and the mucus and cells wet mounted on a glass microscope slide. This was used to confirm the absence or presence of ectoparasites if the mounted gill filament had no parasites.

## Results

### Queensland

Barramundi held in tanks at NFC had low levels of parasites immediately after transport, and parasite numbers remained low for the week following transport (Table 1). Barramundi from a commercial fish farm had higher levels of parasites than fish held at NFC, and parasite numbers increased during the post-transport holding period (Table 2). However, even this proliferation of parasites was insufficient to cause any fish health problems during the post-transport holding period.

Bacterial levels were uniformly low in both experiments, even after holding fish for 1 week following transport (Table 1, Table 2). All samples were well within the required criteria for human consumption.

**Table 1** Results of parasitological and microbiological examinations of barramundi after live transport (Experiment 1).

		Days from receipt	
		1 day	8 days
Parasites	Gills and skin	0 - 1 / fish	0 - 1 / fish
Microbiology	Standard plate count (25°C)	<1 x 10 <sup>2</sup> - 8 x 10 <sup>2</sup> /g	<1 x 10 <sup>2</sup> - 5 x 10 <sup>3</sup> /g
	Salmonellae	0	0
	<i>Vibrio parahaemolyticus</i>	<0.3 - 0.4 MPN /g	< 0.3 MPN /g

**Table 2** Results of parasitological and microbiological examination of barramundi after live transport (Experiment 2).

		Days from receipt	
		1 day	7 days
Parasites	Gills and skin	1-15 / fish	5-46 / fish
Microbiology	Standard plate count (25°C)	2 x 10 <sup>3</sup> - 2.5 x 10 <sup>5</sup> /g	2.7 x 10 <sup>3</sup> - 1.8 x 10 <sup>4</sup> /g
	Salmonellae	0	0
	<i>Vibrio parahaemolyticus</i>	<0.3 MPN /g	<0.3 MPN /g

### Tasmania

Control, transport and post-transport samples of banded morwong showed low or non-detectable levels of bacteria (Table 3). Levels of the potential human health pathogens *Salmonella* and *V. parahaemolyticus* were both extremely low and well within human health standards.

**Table 3** Results of microbiological examination of banded morwong after live transport.  
ND: not detected.

Treatment	TPC/30°C	Salmonellae	<i>Vibrio parahaemolyticus</i>
Control	<10-20	ND	<1
Transport	<10-60	ND	<1
Post-transport	<10-50	ND	<1

### Discussion

Baumann *et al.* (1984) found that the halophilic vibrios were among the major groups of bacteria isolated from the marine environment. The main species of this genus associated with human infections gained through eating seafood (particularly raw oysters) included *Vibrio parahaemolyticus*, *V. vulnificus*, *V. cholerae*, *V. fluvialis* and *V. mimicus* (Klontz *et al.* 1993).

Little work has been done on the carriage of micro-organisms by live fish during transport. Most of the field trials have centred on the testing of seafood at the wholesale/frozen and market/thawed levels (Chan *et al.* 1989, Klontz *et al.* 1993, De Paola *et al.* 1994). The total aerobic count and *V. parahaemolyticus* load is greater on fish in the marketplace than on freshly caught fish because of exposure to temperatures that are more suitable to microbial growth (Sanjeev and Stephen 1993). This is especially true in the ambient temperatures of the tropics if the storage or display areas are not thermostatically controlled. To achieve low counts of aerobic heterotrophs at the holding tanks, it is essential that the bacterial load is at a minimum during the collection and transport stages. Although bacteria from the fish can have a beneficial role by using some of the ammonia produced during transport, the bacterial load, if heavy, can decrease the oxygen levels in the water leaving the fish more susceptible to infection (Johnson 1979).

The two major bacterial concerns in the handling and transportation of live fish from the point of view of human health hazards as laid down by the Australian Standards are *V. parahaemolyticus* and *Salmonella* spp. *V. parahaemolyticus* is a worldwide cause of gastroenteritis (diarrhoea, cramps, vomiting, headache, fever, and chills) with symptoms occurring within 9 - 25 hours of ingestion and lasting 2 - 3 days (Hackney and Dicharry 1988). The infective dose is  $10^6$  -  $10^7$  organisms (Sanyal and Sen 1974), while the recommended hygienic standard is  $10^2$  / g for fish (Sakazaki *et al.* 1979) and lobsters and shrimps (International Commission for the Microbial Specification for Food [ICMSF] 1974).

The percentage of fresh-killed finfish carrying *V. parahaemolyticus* at the marketplace in India has been recorded at 55.8% with counts from  $1 - 10^2$  / g and 11.5% with counts greater than  $10^2$  / g. Three of 17 (17.6%) mackerel had counts greater than  $10^3$  / g (Sanjeev and Stephen 1993).

Chan *et al.* (1989) showed that *V. parahaemolyticus* was associated with mussels, oysters, prawns and fish in Hong Kong with contamination rates of  $4.6 \times 10^4$  / g,  $3.4 \times 10^4$  / g,  $3.2 \times 10^1$  / g and  $8.5 \times 10^1$  / g respectively. The effects were seasonal and contamination occurred



more during the summer months.

Several other *Vibrio* spp. are pathogenic to man after eating seafood and can cause diarrhoea, skin and soft tissue infections and/or septicaemia (Blake *et al.* 1980).

*V. vulnificus* is predominant in summer months and is becoming of increasing importance as a human pathogen although the Australian Standards for Quality Control do not require testing for this organism. *V. vulnificus* causes necrotizing fasciitis (malaise, chills, fever but no diarrhoea or vomiting) and symptoms occur some 16 - 48 hours after ingestion with a fatality rate of 40 - 60% especially in immunocompromised hosts (Hackney and Dicharry 1988). In the USA, it was found in the intestines of bottom-feeding fish at a rate of  $10^6$  / g, particularly in fish feeding on crustaceans and molluscs. In plankton-feeding fish, the count was down to  $10^3$  / g, whilst the organism was found infrequently in off-shore fish (De Paola *et al.* 1994).

Japan is one country that has suffered from seafood-based *Vibrio* infections. In 1994, of the 605 food poisoning cases in Japan, 224 were attributed to *V. parahaemolyticus* (Venkatewaran *et al.* 1996). This is not unexpected due to the custom of the Japanese eating raw fish and other seafood, especially during the summer months.

The total count for aerobic heterotrophic bacteria can vary with the quality of the water (especially with fish grown in aquaculture conditions), the season (usually greater in summer) and transport conditions (length of journey; water to fish ratio; gaseous environment). Chan *et al.* (1989) found that the total count for rabbitfish and grouper were  $6.2 \times 10^4$  / g (with 1% of the total being *Vibrio* spp.) and  $4.5 \times 10^4$  / g (with 1.2% being *Vibrio* spp.) The *V. parahaemolyticus* counts were  $8.2 \times 10^1$  / g and  $8.8 \times 10^1$  / g respectively. The fish were much cleaner than the bottom-feeding bivalves which gave total counts of  $2.4 \times 10^6$  / g (with 6.1% being *Vibrio* spp.). The *V. parahaemolyticus* count was  $3.4 \times 10^4$  / g.

Berry *et al.* (1994) used a total count of  $10^7$  / g as the recommended limit for prawns. In his study of prawns imported to the USA from a number of countries, the majority of prawns passed at this level. However, if the number for 'good quality' of  $10^6$  / g was used, then only 0 - 40% of the prawns from the various countries would be suitable.

With regard to *Salmonella* infections, the incidence in seafood is not uncommon. Fraiser and Koburger (1984) found 43% of clams, 36.7% of crabs, 10% of oysters but no mullet were contaminated with *Salmonella* spp. some 4 hours after harvesting. Like *Vibrio* spp., there is a positive relationship of *Salmonella* spp. contamination to bottom-feeders as opposed to free-swimming fish such as mullet. More *Salmonella* spp. are found in the bottom sediment than in the water above. The finding of a number of different serotypes throughout the year indicated that the *Salmonella* spp. were part of the natural background flora of seafood.

It is essential to keep bacterial counts at the lowest levels possible, especially during the summer months when *Vibrio* spp. are more prevalent. Our results showed low levels of total aerobic heterotrophic bacteria ( $< 1 \times 10^2$  -  $2.5 \times 10^5$  / g), minimal *V. parahaemolyticus* ( $< 0.3$  -  $0.4$  MPN / g) and no *Salmonella* spp. The holding of the live fish for one week post transport showed little change in the results.

However, the barramundi transported from the commercial farm (Table 2) had higher total

counts than the fish transported from the holding facilities at the Northern Fisheries Centre (Table 1) -  $2.5 \times 10^5$  / g versus  $8 \times 10^2$  / g directly after transport and  $1.8 \times 10^4$  / g versus  $5 \times 10^3$  / g after holding for 1 week. This is probably due to the differences in the pond water against the filtered seawater provided to the fish from NFC in experiment 1.

The fish transported in this trial were not bottom-feeders and the lower counts for vibrios and salmonellae are indicative of this. Obviously, clean fish at the commencement of transport leads to a healthier fish at the receival point. The fish counts obtained throughout this trial were well within the limits set by the ICMSF.

The higher levels of ectoparasites on the barramundi from the commercial farm is not surprising. They had been exposed to an open pond environment. This group also showed an increase in the intensity of parasite infestation (Table 2). Parasites with direct life cycles, such as the *Trichodina* sp. and *Diplectanum* sp. present on these barramundi, proliferate quickly in static water conditions as were used for the 7 day holding. As such the increase in parasite numbers probably does not relate to any transport stress. The barramundi remained healthy throughout.

## References

- Baumann, P., Furniss, A.L. and Lee, J.V. (1984). Vibrionaceae. In: 'Bergey's Manual of Systematic Bacteriology', Vol. 1, ed. Kreig and Holt, Baltimore, pp. 516-538.
- Berry, T.M., Park, D.L. and Lightner, D.V. (1994). Comparison of the microbiological quality of raw shrimps from China, Ecuador, or Mexico at both wholesale and retail levels. *J. Food Protect.* 57, 150-153.
- Blake, P.S., Weaver, R.E. and Hollis, D.G. (1980). Diseases of humans (other than cholera) caused by vibrios. *Ann. Rev. Microbiol.* 34, 341-367.
- Chan, K., Woo, M.L., Lam, L.Y. and French, G.L. (1989). *Vibrio parahaemolyticus* and other halophilic vibrios associated with seafood in Hong Kong. *J. Appl. Bacteriol.* 66, 57-64.
- De Paola, A., Capers, G.M. and Alexander, D. (1994). Densities of *Vibrio vulnificus* in the intestine of fish from the US Gulf Coast. *Appl. Environ. Microbiol.* 60, 984-988.
- Fraiser, M.B. and Koburger, J.A. (1984). Incidence of salmonellae in clams, oysters, crabs and mullet. *J. Food Protect.* 47, 343-345.
- Johnson, S.K. (1979). Transport of live fish. In: Davis, J.T. (ed.). Proceedings of 1979 Fish Farming Conference and Annual Convention, Catfish Farmers of Texas, 17-19 January 1979. Texas Agricultural Extension Service, Texas Agricultural Experiment Station, College of Agriculture, The Texas A&M University System.
- Klontz, K.C., Williams, L., Baldy, L.M. and Campos, M. (1993). Raw oyster - associated *Vibrio* infections: linking epidemiological data with laboratory testing of oysters obtained from a retail outlet. *J. Food Protect.* 56, 977-979.
- Sakazaki, R., Kareshimada, T., Yuda, K., Sakai, S., Asakawa, H., Yamzaka, M.,

Nakanishi, H., Kobayashi, T., Okazaki, H., Doke, T. Shinada, T. and Tamura, K. (1979). Enumeration of, and hygienic standard of, food safety for *Vibrio parahaemolyticus*. *Archiv fur Lebesmittellhygiene* 30, 103-105.

Sanjeev, S. and Stephen, J. (1993). Quantitative studies on *Vibrio parahaemolyticus* in market samples of finfish and shellfish from Cochin (South India). *Fish. Res.* 16, 273-276.

Sanyal, S.C. and Sen, P.C. (1974). Human volunteer study on the pathogenicity of *Vibrio parahaemolyticus*. In 'International Symposium of *Vibrio parahaemolyticus*', ed. Fujino *et al.*, Tokyo, pp. 227-230.

Venkatewaran, K., Kurusu, T., Satake, M. and Shinoda, S. (1996). Comparison of a fluorogenic assay with a conventional method for rapid detection of *Vibrio parahaemolyticus* in seafoods. *Appl. Environ. Micro.* 62, 3516-3520.

## Appendix 1 - Check list for road transport operations

### *Truck*

- Suitable for purpose, particularly re. pond access
- Tank location on truck
- Storage area for pumps, hoses, buckets, etc.
- Provision of liquid oxygen, or bottled oxygen (short trips only)
- Driver visible oxygen pressure gauge

### *Tanks*

- Fibreglass tanks, rectangular in shape
- Tanks insulated to control temperature
- Closed tank excludes all light
- Easy tank access to add or remove fish
- Wide drains and gate valves
- Tank sealed to prevent water loss or surging
- Tanks vented to allow off-gassing
- Agitators to assist with off-gassing
- Flow control gauges for oxygen diffusers
- Rheostats or switches for intermittent use of agitators
- Ice or cooling system for temperature control

### *Other*

- Starve fish prior to transport
- Dissolved oxygen (DO) meter
- Test kits for pH, carbon dioxide (CO<sub>2</sub>), ammonia (NH<sub>3</sub> / NH<sub>4</sub><sup>+</sup>)

## **Appendix 2 - Texas Parks and Wildlife Department specifications for fish transportation tanks**

The following is a copy of the Texas Parks and Wildlife Department tender document that details the construction of the tanks used by that department for live fish transport. Tanks used for live fish transport throughout the US are basically similar in construction to these tanks, although details differ, as described in the main section of this report.

### **CUSTOM MADE FIBREGLASS FISH TRANSPORTATION TANK:**

Dimensions: 11' long x 4' wide x 40" tall with 3 separate compartments.

Wall construction: framing to be Douglas fir or spruce, clean/kiln -dried with 10% or less moisture content, no less than 2 x 2 interior and 2 x 4 corner braces, exterior covered with 3/4" A/C exterior grade Douglas fir plywood or marine grade, 1 1/2" closed-cell slab Polyurethane foam (two-pound density per cubic foot) inside to be glued to interior side of 3/4 inch plywood, R value not less than 11, floor 4" thick foam, bottom rails 2" x 4" running full length of tank closed on ends with additional 2" x 4" lumber spaced on 12" centers, all core material to be glued and screwed together, fibreglass lamination polyester resins non-toxic (food grade) to aquatic life, exterior surface 1/8" thick on walls and 1/4" at corners, interior walls composite laminate with alternate layers of 2 oz. fibreglass (Owen Corning or equal) along with 2mm Cormat, adhesive used shall be nontoxic and waterproof. White colored resin on outside and light blue colored blue resin on inside to be free of any lead or cadmium products, all surfaces to be completely encased in fibreglass lamination. Fibreglass laminate shall be finished to a washable smooth finish. Floor of each compartment to be sloped to discharge drain.

Door and hatch features: Not less than 36" x 30" doors to be flush mounted in deck of tank, constructed and insulated with same materials as walls, 2 holddown per hatch to be 'De-Sta-Co' stainless steel toggle clamps, mod. 225-USS (500 pound capacity) or equal, 2 per hatch aluminium jack-knife safety lid supports, 3" 'Perko' stainless steel polished locker ventilators in center of each hatch, 6" chrome handles, continuous 3" open aluminium hinges with 1/4" diameter stainless steel pin, 1/2" diameter half-round extruded silicon rubber door gaskets.

Tank holddowns: 3" x 3" x 1/4" structural aluminium angle iron holddown bolted to ends of tank's support rail framework with 1/2" stainless steel bolts.

Drains: Each compartment to have 6" diameter schedule 80 PVC threaded side drains screwed and laminated to tank exterior over a previously fibreglassed hole equipped with 'Kamlock' 633A aluminium adaptor and 'Kamlock' 634-B aluminium caps. Each drain to have a polyurethane, stainless steel or aluminium internal water-tight slide-gate assembly with inside compartment pull rod. Drains to be located in back corner of each compartment. Overflow drains in each compartment at 28" water level to be 2" diameter 'Snap-Tite' marine drain plug screened on inside with PVC

perforated disc having ¼” holes, each compartment to have 2” bleeder valve 6” from bottom of tank equipped with PVC gate valve and screened on inside with PVC perforated disc having ¼” holes.

Agitator porthole: Each compartment to have on 4.75” diameter porthole equipped with two ‘De-Sta-Co’ holddowns.

The construction of the tank shall result in a solid composite of all materials. All pipes, conduits, etc. passing through walls, floors, decks, and bottoms of tank shall be watertight. All ports shall be fibreglassed to prevent leakage into walls, floors, and tops of tank.

Electrical hook-up: Wiring to be routed through PVC conduit embedded within deck of tank, weatherproof junction box positioned on front end of tank and outlet boxes in close proximity to agitator porthole, all electrical items used to be weatherproof and designed especially for outdoor use.

Oxygenation: To include plastic piping (Schedule 80 PC) from front of tank to a ‘Smith’ oxygen dispersion material at each compartment, from flowmeter to inside of each compartment a 5/16” dia. O.D. LDPE flexible tubing (2 feet long) to include oxygen diffuser in each compartment.

Tanks to have a minimum limited 5 year warranty on materials and workmanship. Tank will be replaced at bidder expense due to de-lamination or leakage to interior walls or outside of tank (repairs will not be acceptable).

### Appendix 3 - Saturation values for dissolved oxygen

Solubility of oxygen (mg/l) in water over a range of temperatures at different salinities. DO values are 100% saturation in water exposed to water-saturated air at sea level. Reference: Merrick, J.R. and Lambert, C.N. (1991). The Yabby, Marron and Red Claw - Production and Marketing. J.R. Merrick, Artarmon, N.S.W. 180 pp.

Temp. (°C)	Salinity (ppt)									
	0	5	10	15	20	25	30	35	40	45
0	14.6	14.1	13.6	13.2	12.7	12.3	11.9	11.5	11.1	10.7
5	12.8	12.3	11.9	11.6	11.2	10.8	10.5	10.1	9.8	9.5
10	10.9	10.6	10.3	9.9	9.6	9.3	9.0	8.8	8.5	
15	10.1	9.8	9.5	9.2	8.9	8.6	8.4	8.1	7.9	7.6
20	9.1	8.8	8.6	8.3	8.1	7.8	7.6	7.4	7.2	7.0
25	8.2	8.0	7.8	7.6	7.4	7.2	7.0	6.8	6.6	6.4
30	7.5	7.3	7.1	6.9	6.8	6.6	6.4	6.2	6.1	5.9
35	6.9	6.8	6.6	6.4	6.2	6.1	5.9	5.8	5.6	5.5
40	6.4	6.3	6.1	5.9	5.8	5.6	5.5	5.4	5.2	5.1

## Appendix 4 - Proportion of unionised (NH<sub>3</sub>) ammonia

Percentage of total ammonia (NH<sub>3</sub> + NH<sub>4</sub><sup>+</sup>) present as un-ionised ammonia (NH<sub>3</sub>) in aqueous solution at different pH values and temperatures.

Reference: Boyd, C.E. (1990). Water Quality in Ponds for Aquaculture. Auburn University, Alabama. 482 pp.

pH	Temperature (°C)								
	16	18	20	22	24	26	28	30	32
7.0	0.3	0.3	0.4	0.5	0.5	0.6	0.7	0.8	1.0
7.2	0.5	0.5	0.6	0.7	0.8	1.0	1.1	1.3	1.5
7.4	0.7	0.9	1.0	1.1	1.3	1.5	1.7	2.0	2.4
7.6	1.2	1.4	1.6	1.8	2.1	2.4	2.7	3.1	3.7
7.8	1.8	2.1	2.5	2.8	3.2	3.7	4.2	4.9	5.7
8.0	2.9	3.3	3.8	4.4	5.0	5.7	6.6	7.5	8.8
8.2	4.5	5.2	5.9	6.8	7.7	8.8	10.0	11.4	13.2
8.4	6.9	7.9	9.1	10.3	11.7	13.2	15.0	17.0	19.5
8.6	10.6	12.0	13.7	15.4	17.3	19.4	21.8	24.5	27.7
8.8	15.8	17.8	20.1	22.4	24.9	27.6	30.7	33.9	37.8
9.0	22.9	25.6	28.5	31.4	34.4	37.7	41.2	44.8	49.0
9.2	32.0	35.3	38.7	42.0	45.4	49.0	52.7	56.3	60.4
9.4	42.7	46.3	50.0	53.5	56.9	60.3	63.8	67.1	70.7
9.6	54.1	57.8	61.3	64.5	67.6	70.7	73.6	76.4	79.3
9.8	65.2	68.4	71.5	74.3	76.8	79.3	81.6	83.7	85.9
10.0	74.8	77.5	79.9	82.1	84.0	85.8	87.5	89.1	90.6
10.2	82.5	84.5	86.3	87.9	89.3	90.6	91.8	92.8	93.8