

Sydney rock oysters: Overcoming constraints to commercial scale hatchery and nursery production

Wayne A. O'Connor, Michael Dove, Ben Finn

NSW Department of Primary Industries
Port Stephens Fisheries Centre
Private Bag 1, Nelson Bay, NSW 2315
Australia



FRDC Project No. 2003/209

October 2008

NSW Department of Primary Industries –
Fisheries Final Report Series

No. 104

ISSN 1449-9967



NSW DEPARTMENT OF
PRIMARY INDUSTRIES



AUSTRALIAN
SEAFOOD
COOPERATIVE
RESEARCH CENTRE

ORAC
NSW Oyster Research Advisory Committee



Australian Government

**Fisheries Research and
Development Corporation**

Sydney rock oysters: Overcoming constraints to commercial scale hatchery and nursery production

October 2008

Authors: Wayne A. O'Connor, Michael Dove and Ben Finn
Published By: NSW Department of Primary Industries (now incorporating NSW Fisheries)
Postal Address: Port Stephens Fisheries Centre, Private Bag 1, Nelson Bay, NSW, 2315
Internet: www.dpi.nsw.gov.au

© NSW Department of Primary Industries, the Fisheries Research & Development Corporation, NSW Oyster Research Advisory Committee and Seafood CRC

This work is copyright. Except as permitted under the Copyright Act, no part of this reproduction may be reproduced by any process, electronic or otherwise, without the specific written permission of the copyright owners. Neither may information be stored electronically in any form whatsoever without such permission.

DISCLAIMER

The publishers do not warrant that the information in this report is free from errors or omissions. The publishers do not accept any form of liability, be it contractual, tortious or otherwise, for the contents of this report for any consequences arising from its use or any reliance placed on it. The information, opinions and advice contained in this report may not relate to, or be relevant to, a reader's particular circumstance.

ISSN 1449-9967

(Note: Prior to July 2004, this report series was published as the 'NSW Fisheries Final Report Series' with ISSN number 1440-3544)

TABLE OF CONTENTS

TABLE OF CONTENTS	III
LIST OF FIGURES	IV
LIST OF TABLES	VI
ACKNOWLEDGEMENTS	VII
NON-TECHNICAL SUMMARY	VIII
1. BACKGROUND	12
2. NEED	15
3. OBJECTIVES	15
4. RESEARCH & DEVELOPMENTS	16
4.1. <i>Salinity and temperature tolerance of Sydney rock oysters <i>Saccostrea glomerata</i> during early ontogeny</i>	16
4.2. <i>Ecotoxicological evaluations of common hatchery substances and procedures used in the production of Sydney rock oysters <i>Saccostrea glomerata</i></i>	31
4.3. <i>Ontogenetic variation in dietary preferences of Sydney rock oyster, <i>Saccostrea glomerata</i>, larvae and spat</i>	44
4.4. <i>Suitability of a commercially available algal substitute for culture of Sydney rock oyster <i>Saccostrea glomerata</i> spat</i>	51
4.5. <i>Evaluation of spat bottles for rearing Sydney rock oyster <i>Saccostrea glomerata</i> spat</i>	55
4.6. <i>The tolerance of Sydney rock oyster, <i>Saccostrea glomerata</i> spat to air exposure and the implications for transportation</i>	59
4.7. <i>Commercial assessments of growth and mortality of fifth generation Sydney rock oysters <i>Saccostrea glomerata</i> selectively bred for faster growth</i>	68
4.8. <i>Gonad development of fifth generation Sydney rock oysters <i>Saccostrea glomerata</i> selected for fast growth</i>	81
5. BENEFITS	94
6. FURTHER DEVELOPMENT	96
7. PLANNED OUTCOMES	97
8. CONCLUSIONS	98
9. REFERENCES	99
10. APPENDICES	100
10.1. <i>Appendix 1 – Intellectual Property</i>	100
10.2. <i>Appendix 2 – Staff</i>	100
10.3. <i>Handling guidelines for hatchery single seed oyster stock</i>	101
10.4. <i>Introduction to nurseries for hatchery produced oyster spat</i>	106
10.5. <i>Procedures for routine oyster spat sampling</i>	110
10.6. <i>Key changes to production methodology for SRO larval and spat rearing</i>	114

LIST OF FIGURES

SECTION 4.1. Salinity and temperature tolerance of Sydney rock oysters during early ontogeny

Figure 1.	Experiment 1 surface-response plots with isolines estimating the mean percentage of <i>S. glomerata</i> embryos to develop to D-veligers after: 16 h, 20 h, 24 h and 40 h at a range of temperature and salinity levels.	20
Figure 2.	Experiment 2 surface-response plots with isolines estimating the mean percentage survival of <i>S. glomerata</i> larvae at: the D-veliger stage; umbonate stage; and, pediveliger stage.	21
Figure 3.	Experiment 2 surface-response plots with isolines estimating the mean growth increase of <i>S. glomerata</i> larvae at: the D-veliger stage; umbonate stage; and, pediveliger stage.	22
Figure 4.	Mean percentage settlement at 26 and 30°C and at four salinities (Experiment 3).	23
Figure 5.	Experiment 4 surface-response plot with isolines estimating the mean percentage survival of <i>S. glomerata</i> spat.	24
Figure 6.	Experiment 4 surface-response plot with isolines estimating the mean growth increase of <i>S. glomerata</i> spat.	24
Figure 7.	Mean percentage survival of <i>S. glomerata</i> spat at 12 salinity levels (Experiment 5).	25
Figure 8.	Mean growth increase of <i>S. glomerata</i> spat over the 17 day experimental period (Experiment 5).	25

SECTION 4.2. Ecotoxicological evaluations of common hatchery substances and procedures used in the production of Sydney rock oysters

Figure 1.	Micrograph of abnormal, undeveloped and normal <i>Saccostrea glomerata</i> D-veliger larvae from 1% rainwater treatment at 48 h post fertilisation.	34
Figure 2.	<i>S. glomerata</i> embryonic development after 48 h exposure to various hatchery toxicants, deionised water or following repeated screening of fertilised eggs.	38

SECTION 4.3. Ontogenetic variation in dietary preferences of Sydney rock oyster larvae and spat

Figure 1.	Experimental downwelling system used for spat culture.	46
------------------	---	----

SECTION 4.5. Evaluation of spat bottles for rearing Sydney rock oyster spat

Figure 1.	PSFC bivalve hatchery spat bottle system containing <i>S. glomerata</i> spat.	56
Figure 2.	Mean spat size in bottles and screens during Trial 1, 2 and 3.	57

SECTION 4.6. The tolerance of Sydney rock oyster spat to air exposure and the implications for transportation

Figure 1.	Capped 120 ml vials used for spat emersion for Experiment 2.	61
Figure 2.	Survival of three different size grades of spat to air exposure at 25°C.	62
Figure 3.	Survival of 1334 µm spat and 2278 µm spat at temperatures between 19°C and 33°C.	63
Figure 4.	Survival of spat (average size 1334 µm) to emersion when fully exposed, protected in sealed bags and protected in oxygenated sealed bags.	64

SECTION 4.7. Commercial assessments of growth and mortality of fifth generation Sydney rock oysters selectively bred for faster growth

Figure 1.	Map of the NSW coast showing locations of estuaries where farming sites were located.	70
Figure 2.	Whole oyster weight of Control and Line 2 <i>S. glomerata</i> farmed by oyster growers in seven estuaries in NSW.	73
Figure 3.	Shell height of Control and Line 2 <i>S. glomerata</i> farmed by oyster growers in seven estuaries in NSW.	75

Figure 4.	Cumulative mortality (%) of Control and Line 2 <i>S. glomerata</i> farmed by oyster growers in seven estuaries in NSW from April 2004 to July 2006.	77
------------------	--	----

SECTION 4.8. Gonad development of fifth generation Sydney rock oysters selected for fast growth

Figure 1.	Map of the NSW coast showing locations of estuaries used as field sites and origin estuaries of Control oyster broodstock.	83
Figure 2.	Shell height of L2 and Control <i>Saccostrea glomerata</i> oysters from June 2005 to June 2006 at the Camden Haven River, Shoalhaven River and Wagonga Inlet field sites.	85
Figure 3.	Whole weight of L2 and Control <i>Saccostrea glomerata</i> oysters from June 2005 to June 2006 at the Camden Haven River, Shoalhaven River and Wagonga Inlet field sites.	86
Figure 4.	Shell height of L2 and Control <i>Saccostrea glomerata</i> oysters from June 2005 to June 2006 at the Camden Haven River, Shoalhaven River and Wagonga Inlet field sites.	88
Figure 5.	Monthly frequency of gonadial phases in Control and L2 <i>Saccostrea glomerata</i> oysters in the Camden Haven River, NSW, from June 2005 to July 2006.	90
Figure 6.	Monthly frequency of gonadial phases in Control and L2 <i>Saccostrea glomerata</i> oysters in the Shoalhaven River, NSW, from June 2005 to July 2006.	91
Figure 7.	Monthly frequency of gonadial phases in Control and L2 <i>Saccostrea glomerata</i> oysters in Wagonga Inlet, NSW, from June 2005 to July 2006.	92

LIST OF TABLES

SECTION 4.1. Salinity and temperature tolerance of Sydney rock oysters *Saccostrea glomerata* during early ontogeny

Table 1.	Optimal salinity and temperature for survival and growth of <i>S. glomerata</i>	28
-----------------	--	----

SECTION 4.2. Ecotoxicological evaluations of common hatchery substances and procedures used in the production of Sydney rock oysters

Table 1.	Details of hatchery substances and the procedure tested in preliminary range finding tests on <i>S. glomerata</i> embryos.	32
Table 2.	Preliminary range finding test exposure levels and proportion of abnormal development.	35
Table 3.	Definitive toxicity test results for <i>S. glomerata</i> embryos exposed to substances commonly used for larval rearing at the PSFC bivalve hatchery.	36
Table 4.	Chemical analysis results of seawater (diluent), deionised water, bore water and rainwater samples collected at the PSFC bivalve hatchery.	41

SECTION 4.3. Ontogenetic variation in dietary preferences of Sydney rock oyster larvae and spat

Table 1.	Growth of <i>S. glomerata</i> of various ages fed one of a range of diets for seven days.	48
-----------------	--	----

SECTION 4.4. Suitability of a commercially available algal substitute for culture of Sydney rock oyster spat

Table 1.	‘M1’ in combination with fresh <i>C. muelleri</i> as a food source for <i>S. glomerata</i> spat.	53
-----------------	---	----

SECTION 4.5. Evaluation of spat bottles for rearing Sydney rock oyster spat

Table 1.	Description of Trials 1, 2 and 3 and spat growth rate expressed as % increase per day.	57
-----------------	---	----

SECTION 4.6. The tolerance of Sydney rock oyster spat to air exposure and the implications for transportation

Table 1.	Summary of the two factor ANOVA results for small (1334 µm) and large (2278 µm) spat from Experiment 2.	64
Table 2.	Results of the two factor ANOVA for comparison of time of removal and type of emersion. .	65

SECTION 4.7. Commercial assessments of growth and mortality of fifth generation Sydney rock oysters selectively bred for faster growth

Table 1.	Culture methods for Line 2 and Control <i>S. glomerata</i> oysters grown by commercial oyster growers in NSW from March 2004 to June 2006.	71
Table 2.	Available temperature and salinity information (1966 – 1973) from Wolf and Collins (1979) for field sites used in this study.	78

ACKNOWLEDGEMENTS

We would like to extend our thanks to the staff of Port Stephens Fisheries Centre for their assistance during this project, in particular our colleagues Stephan O'Connor and Lynne Foulkes for their considerable technical support. Drs Geoff Allan, Mark Booth, Stewart Fielder and John Nell provided valuable editorial comments and assistance during preparation of the material incorporated into this report. The role of Dr Michael Heasman in the inception and development of this program is also gratefully acknowledged.

Special thanks are extended to the following NSW oyster farmers for their considerable assistance and support in the field during this project: Colin & Warren Auld, Noel Baggley, Chris and Domonic Boyton, Jane Clout, John & Annette Collison, Geoff Diemar, Clayton Harrington, David Maidment, Stephan Paschalidis, John Smith, Audrey Thors, Tony Troup, Ray Tynan, Steve and Maurie Verdich, and Jeff Wright. The members of the Oyster Research Advisory Committee are thanked for their input into the development and ongoing operation of this program (Prof. Ian White, Geoff Diemer, Audrey Thors, Domonic Boyton, Tony Troup and Ray Tynan), as are the directors of the Select Oyster Company (Mark Bulley, Greg Commerford, David Maidment, Robbie Moxham, Tony Troup, Ray Tynan).

The progress of this program in establishing commercial SRO spat supply has in no small part been due to the considerable skills of Nik and Chalad Duyst who have undertaken commercial production of SRO for the industry.

Specialist advice was received from Rod Grove-Jones, Martin John and Richard Pugh. We also thank Associate Professor Hugh Dunstan and his staff in the School of Environmental and Life Sciences for advice and assistance with biochemical analyses.

NON-TECHNICAL SUMMARY

2003/209	Sydney rock oysters: Overcoming constraints to commercial scale hatchery and nursery production
----------	---

PRINCIPAL INVESTIGATOR: Wayne O'Connor

ADDRESS: NSW Department of Primary Industries
Port Stephens Fisheries Centre
Private Bag 1
Nelson Bay, NSW, 2315
Telephone: 02 49821232 Fax: 02 4981107

OBJECTIVES:

1. To establish protocols for improved broodstock conditioning and handling, particularly to permit out-of-season spawning of selected oyster stocks.
2. To determine the effects of the key autecological factors (temperature and salinity) and nutrition on SRO embryos and larvae, to elevate early larval survival and late larval growth in commercial hatcheries.
3. To trial economical, low cost alternative techniques for algal and larval and spat rearing to enhance commercial SRO production. In particular to establish alternative approaches for spat rearing including spat bubblers and field based nursery systems.
4. To systematically assess and monitor the major potential pathogenic factors that might contribute to spat mortality.
5. To facilitate the establishment of a reliable commercial source of genetically improved SRO spat.

As a function of the early success of this program in overcoming hatchery production problems, two additional milestones were added with the objective:

6. To assess the performance of selectively bred oysters at seven sites across NSW and then monitor the changes in physiological and reproductive condition of those oysters at 3 of those sites.

NON TECHNICAL SUMMARY:

Outcomes Achieved

Chronic failure of attempts by hatcheries to reliably produce commercial quantities of Sydney rock oyster (SRO) seed has occurred in NSW for more than two decades. In a review of hatchery performance, Heasman *et al.* (2000) found that approximately 56% of SRO larval batches failed within the first 8 days, and of those runs that were successful, a further 58% suffered spat mass mortality syndrome (SMMS). Collectively these mortalities denied the SRO industry the opportunity to reliably access the advantages of selectively bred oysters. These advantages include significantly increased growth rates (30%) and resistance to major diseases such as "QX". The primary aim of this project was to develop the technology and establish the conditions under which

reliable, commercial, industry based, supply of selectively bred spat was possible. This has been achieved and commercial production has begun.

At the outset of this program in 2003, no hatchery produced SRO spat were available in NSW. In the past four years, over 70 million selectively bred spat were distributed to industry, culminating in the supply of nearly 40 million spat in the 2006/07 season. The latter represents an estimated 30% of industry spat supply derived from selected stocks, with significant further increases in uptake predicted. Within the hatchery, this outcome was achieved through incremental improvements in protocols and technology (Appendix 10.6 & documented in the Hatchery Manual). In particular we have ascribed much of the improvement in early larval performance to improved seawater management and better storage and delivery infrastructure. Commercially, the active involvement of industry participants in establishing a hatchery, nurseries and the commercial vehicle for the management of spat distribution (The Select Oyster Company, SOCO) has been critical.

Central to the timely supply of oyster seed is the ability to access reproductively mature adults throughout the season. Protocols were in place to achieve this (Frankish *et al.* 1991); however persistent early failure of larval batches called into question their efficacy. Throughout this project, 42 larval production runs were undertaken, the majority (>90%) of which were produced using broodstock conditioned based on existing protocols. Further these protocols were used to condition broodstock that was supplied to commercial hatchery operators in Queensland that were used to supply seed to SRO farmers. In total, 38 (90%) of these runs performed well, without significant larval mortality. Therefore, in agreement with Heasman *et al.*, (2000) we have concluded these protocols were not the cause of previous failures and have retained these protocols with only minor amendment (see Hatchery Manual). Investigations of the applications of these protocols did however suggest that time frames required to condition selectively bred broodstock were on average greater than that previously required for non-selected oyster conditioning.

The SRO Hatchery Health Workshop (FRDC 2002/206) and the resultant HACCP Plan identified the potential for chronic larval losses to have arisen from a range of common hatchery chemicals and procedures. Accordingly a hatchery audit identified a number of potential toxicants and stressors that were assessed by quantifying changes to larval development after 48 h exposure to the substance or procedure. Cleaning agents such as chlorine, Virkon S®, bore water and stored rainwater were found to significantly affect larval development at practical/commercially relevant concentrations. In contrast, handling procedures for screening fertilised eggs did not significantly decrease development percentage after 48 h incubation.

To improve the efficiency of larval production, considerable attention was paid to the impact of variations in temperature and salinity on SRO embryo, larval and spat performance. Changes in optima were noted and incorporated in hatchery production procedures. In addition to these modifications, assessments were made of the changing dietary preferences of SRO larvae and spat. Enhanced SRO larval growth was found to arise from the addition of diatom species such as *Chaetoceros muelleri* to the diet much earlier than had previously been practiced.

Among the key changes to larval rearing protocols, has been the inclusion of epinephrine settlement protocols (see Hatchery Manual) to replace settlement on shell cultch. Epinephrine settlement has accelerated the separation of newly settled seed from settling larvae and larvae which ultimately do not set and die in the system. Epinephrine set has increased the capacity of the set system, but critically, the introduction of this practice has coincided with the complete disappearance of SSMS.

The cost of hatchery production of SRO spat was seen as a potential barrier to the entry of commercial hatchery operators for the SRO industry. Accordingly a number of trials were

undertaken to assess economical, low cost alternative techniques to enhance commercial SRO production. Key amongst these technologies were alternative approaches for spat rearing including spat bubblers, artificial diets and field based nursery systems. Spat bubblers, similar to those used for the production of Pacific oysters, were found to be a low cost space efficient means of handling SRO spat up to a size of 1.5 mm. A size at which they have comfortably exceeded the minimum size for distribution to field based nurseries. A new artificial diet, Nosan M1, was found to be a useful partial substitute in spat diets reducing overall algal feed demand by a minimum of 50%.

To assess potential pathogenic factors in SRO production a significant increase in larval health monitoring was established. Following consultation with disease experts and pathologists, an extensive program of sample collection was undertaken from the outset of this project. In the hatchery, daily larval samples from each larval run were collected and either frozen (-80°C) or fixed in formalin or ethanol. For nurseries, which were operated by industry participants, equipment and advice was provided on when and how to collect samples, particularly in the event of mortality (see appendices). Ultimately, the massive reduction in larval losses and the absence of the spat mass mortality syndrome experienced over the last four years has meant that we have made no progress in identifying pathogens that may have been associated with the previously existing syndromes. However, these health monitoring practices have been useful and have been retained by commercial nursery operators. During this program, two significant spat mortality events (30 – 50%) did occur in 2005 that were asymptomatic of SMMS. The presence of a network of field nurseries and existence of the industry sampling protocol allowed these mortality events to be ascribed to poor transport practices, which have since been overcome. Today nurseries continue to monitor spat health and can use these samples as a record of nursery performance and in the identification of causes of spat growth reduction.

The success of this program has always been reliant upon the involvement of commercial hatchery and nursery operators. To facilitate this involvement, NSW DPI undertook a number of initiatives: 1) DPI encouraged industry based oyster nurseries through assistance with equipment design and the provision of advice; 2) DPI arranged experimental permits for the establishment of new nurseries; 3) initially, DPI produced all the spat ordered by industry and coordinated sales; 4) during initial production batches, field nursery involvement was encouraged through arrangements under which participants were only charged for spat sold, allaying concerns of financial loss through SMMS. 5) NSW DPI called for expressions of interest from hatchery providers and have assisted Newtech Aquaculture to become the primary hatchery seed provider; 6) DPI provided back-up for spat production shortfalls in 2005 and has continued to offer this assurance to industry (although not required since 2005); 6) DPI has continued to support Newtech Aquaculture through the provision of conditioned broodstock and 7) DPI has provided essential regulatory support for the establishment of the hatchery and nursery operations (permits, biosecurity protocols etc). Ultimately SRO farmers now have a commercial hatchery capable of supplying current industry needs. A network of 14 field nurseries has been established from the far south of NSW to southern Queensland and the industry has established SOCo who have taken over the role of coordinating hatchery produced seed sales for the industry.

The early progress in the provision of seed to industry, provided an opportunity to monitor the performance of selectively bred seed on farms across NSW to confirm that results obtained by researchers in Port Stephens would also be achieved in other areas and using alternate farming techniques. This study involving seven farms, from Merimbula in southern NSW to the Kalang River in the north, found that on average, spat selectively bred for fast growth reached harvest size in less than 2.5 years, a year faster than the industry average and at harvest were 27% heavier than controls grown at the same sites. These results were consistent with predictions based on performance of the same stock in Port Stephens. Having reached maturity, the reproductive behaviour of this stock varied according to estuary. In both the Camden Haven River and at Narooma, selectively bred stock showed similar reproductive condition to that of control oysters.

But selectively bred oysters held in the Shoalhaven River had consistently lower condition indices than controls. Therefore, oysters selectively bred for fast growth had a mixed response in terms of their reproductive behaviour when compared against the Control oysters at the three field sites.

KEYWORDS: Sydney rock oyster; *Saccostrea glomerata*; Hatchery, Nursery, Production

1. BACKGROUND

The 120 year old Sydney rock oyster industry directly employs about 800 people, more than any other form of aquaculture in Australia. However, it has suffered a 40% decline from peak production during the 1970's, representing lost gross annual revenue of about \$20 million and hundreds of jobs in regional NSW from Tweed Heads to Eden.

There are a number of reasons for the decline in this industry. Catastrophic and financially ruinous losses due to QX disease in northern NSW estuaries and the Georges River, south of Sydney, have reduced production in those estuaries by about 97%. Lack of profitability, brought about by increased costs and prices that have not kept pace are forcing many farmers, some of whose families have farmed oysters for generations, to abandon the industry. The increased costs are associated with maintaining a new quality assurance program (that includes compulsory purification), increased labour costs and increased costs for government approvals. On the other side of the ledger, increased competition from faster growing Pacific oysters from Tasmania, South Australia and New Zealand, have kept prices down. Sophisticated economic analyses (modelled as part of a NSW Fisheries/ORAC initiative) and the analyses presented by Benzie *et al.* (FRDC 2001/213) demonstrate that profitability will be greatly improved if farmers can grow single seed hatchery produced SRO's selected for faster growth and resistance to disease.

In recognition of the long-term potential of genetically improved oysters, the Federal Government, through the Fisheries Research and Development Corporation (FRDC), and the NSW Government, has invested several million dollars over the last ten years to develop genetically improved *S. glomerata*. Selected lines have been shown to have significantly superior growth compared with non-selected control lines. Major advantages have also been demonstrated in relation to hatchery produced triploid Sydney rock oysters over diploid siblings. Advantages include significantly faster growth, allowing oysters to reach market-size up to 6 months earlier than unselected control groups, and enhanced resistance to disease. Recently the advantages conferred by triploidy and genetic selection have been shown to be at the very least additive allowing triploid, selected oysters to reach market-size 10 months earlier than controls. The selective breeding program has been extended to target resistance to the two most important intracellular parasites, Winter Mortality and QX disease. A significant reduction in mortality following exposure to QX, as well as substantially faster growth, has been demonstrated for disease resistant lines.

Use of hatchery produced rather than wild caught *S. glomerata* spat is therefore becoming increasingly important to the NSW oyster industry and it is important that reliable, large-scale hatchery production of the *S. glomerata* single spat is developed. Unfortunately, although production of tens or hundreds of thousands of spat have been regularly achieved (allowing the mass selective breeding program to proceed), major difficulties have been experienced over the past decade in routine mass hatchery and nursery rearing to produce the millions of spat required for commercial operation. These problems have been experienced at the NSW DPI, PSFC hatchery and also at several commercial hatcheries, all of which have been forced to cease operation because of their failure to overcome the mortality.

Large batches of several million SRO spat have been produced at the PSFC, indicating it is possible, but the frequency with which larval and spat mortality have occurred make it impossible at this time to commercialise Sydney rock oyster hatchery technology. An analogous pattern of continuing failure has been experienced in Australia, and overseas, with other species of molluscs, crustaceans and fish. Problems with attempting to rear commercial scallops, *Pecten fumatus*, were only overcome after scientifically rigorous redefinition of protocols for conditioning broodstock and rearing larvae and spat. Mud crabs are now successfully reared on a laboratory scale but large

scale commercial rearing is still problematic in Australia (although it has been accomplished in three South East Asian countries). Striped trumpeter has, so far, thwarted intensive efforts to develop mass rearing techniques, as have several species of grouper. When species are difficult to rear a similar series of questions arise. Are the difficulties caused by poor facilities, inexperienced staff, unknown diseases or poor nutrition, or is the species itself not amenable to culture.

For Sydney rock oysters, two key complementary strategies were undertaken to address all these questions. In the first strategy, NSW Fisheries implemented simple but potentially significant modifications to existing bivalve hatchery facilities, rearing equipment and operating protocols at PSFC. These changes were made in accordance with recommendations of the Review of Hatchery Production Technology and Breeding program for Sydney Rock Oysters (Benzie *et al.*, FRDC 2001/213), on advice received at the Sydney Rock Oyster Hatchery and Nursery Health Workshop, and on the basis of a commissioned hatchery audit and HACCP plan. The audit, conducted by an independent commercial hatchery operator, Mr Martin John, and the HACCP plan developed in conjunction with Dr David Kennedy, of AusVet Animal Health Services.

In a second strategy, to determine if in-house factors were responsible for variable hatchery success, Mr Nik Duyst of New Tech Aquaculture, Hervey Bay, was commissioned to conduct a series of external SRO seed production trials, using NSW SRO stock. On the first hatchery attempt the larval anorexia syndrome was encountered on Day 4, confirming that the larval mortality syndrome is not confined to NSW. The symptoms were typical of the worst case larval mortality episodes experienced at PSFC and resulted in the termination of the production run. Mr Duyst believed that improved broodstock management protocols might overcome the anorexia experienced and thus NSW Fisheries, after consultation with ORAC, agreed to fund further larval trials at Hervey Bay to test this hypothesis. The next two attempts at Hervey Bay were highly successful, but larval growth and survival were atypical of that observed at PSFC. Initial yields of D-veligers were poorer than expected but subsequent percentage survivals until settlement were excellent. Larval growth was initially significantly faster than ever recorded at PSFC, although, toward settlement, growth rates fell to levels below that expected at PSFC and the subsequent time taken to reach settlement was the same as expected at PSFC. The fourth larval run, in contrast to the two previous runs, used solely hatchery conditioned broodstock as ripe ready to spawn broodstock were not available from the wild. This run also produced sufficient larvae to be considered commercially successful (16 million to set), but, D-veliger yields were again poor, and growth rates and survival were significantly reduced from that observed in the previous two runs and were poorer than would be expected for successful runs at PSFC.

The hatchery trials in Hervey Bay have provided a significant breakthrough, in that they have met the criteria of achieving three consecutive successful larval batches set to demonstrate the ability to overcome the early larval mortality syndrome. In doing so, these trials have allowed research to narrow its focus and progress more rapidly toward commercialisation. Within the hatchery, research will now concentrate on improvements to the techniques used in Hervey Bay and ensuring their portability. In particular, the areas of broodstock management highlighted in the first and fourth larval runs in Hervey Bay and to a lesser extent the poor early larval development and slow late larval growth observed in the second, third and fourth larval runs, will be addressed. In the nursery, the successes have allowed the R&D timetable to be accelerated. Trials to improve settlement success and spat survival will be integrated into the first year of research, along with the establishment of farmer-operated, field based nursery systems to rear progeny of genetically selected SRO.

A systematic 3-year program of R&D is proposed that will:

1. Build on the success in Hervey Bay by focussing on those areas in which further improvements to production techniques can be made to ensure commercial reliability.
2. Allow attempts to immediately commence the commercialisation of improved SRO genetic stock through production runs scheduled to commence in September 2003.
3. Facilitate an early assessment of improved settlement/nursery technology and field based nursery systems to overcome spat mortality.
4. Ensure the portability of the commercial production technology developed.

2. NEED

A systematic program of research and development is needed to promote reliable cost-effective hatchery production of Sydney rock oyster (SRO) seed to allow demonstrated benefits of triploid oysters and advances in SRO selection for growth and disease resistance. This R&D program incorporates the recommendations of the recent “Review of Hatchery Production Technology and Breeding Program for Sydney Rock Oysters” (Benzie *et al.*, FRDC 2001/213) and the NSW Fisheries – FRDC “Sydney Rock Oyster Hatchery and Nursery Health Workshop” held on the 8th and 9th of August 2002 at Nelson Bay. Central among these recommendations were:

- The need for a revision of hatchery procedures and the assessment/adoption of alternate algal, larval and spat rearing technology.
- The need to elucidate the fundamental autecological (temperature and salinity) and nutritional requirements of SRO during early ontogeny, that have not yet been addressed and will be central to the production of the species.
- The need for systematic and appropriate sampling procedures for the diagnosis of potential disease occurrences.

Independent of the species involved, there is a need to document the processes involved in developing techniques and strategies to culture otherwise intransigent species. This research will provide a unique opportunity to document the history of problems with SRO, the consultation undertaken, the strategies developed for SRO and the techniques for their implementation. This document, the FRDC final report for this research, would provide a reference for dealing systematically with hatchery based problems and will provide an array of monitoring and assessment protocols for other molluscs.

3. OBJECTIVES

1. To establish protocols for improved broodstock conditioning and handling, particularly to permit out-of-season spawning of selected oyster stocks.
2. To determine the effects of the key autecological factors (temperature and salinity) and nutrition on SRO embryos and larvae, to elevate early larval survival and late larval growth in commercial hatcheries.
3. To trial economical, low cost alternative techniques for algal and larval and spat rearing to enhance commercial SRO production. In particular to establish alternative approaches for spat rearing including spat bubblers and field based nursery systems.
4. To systematically assess and monitor the major potential pathogenic factors that might contribute to spat mortality.
5. To facilitate the establishment of a reliable commercial source of genetically improved SRO spat.
6. To assess the performance of selectively bred oysters at seven sites across NSW and then monitor the changes in physiological and reproductive condition of those oysters at 3 of those sites.

4. RESEARCH & DEVELOPMENTS

4.1. Salinity and temperature tolerance of Sydney rock oysters *Saccostrea glomerata* during early ontogeny

4.1.1. Introduction

The overriding objective of this project was to overcome constraints to commercial scale production. Research focussed on elevating early larval and spat survival and growth by investigating the impacts of various hatchery procedures (Dove & O'Connor, 2007), rearing practices, diets and the effects of key autecological factors, such as salinity and temperature.

The combined effects of temperature and salinity on early life stage of *S. glomerata* have not been investigated before. However, Nell and Holliday (1988) determined the optimal salinity for *S. glomerata* D-veliger larvae at 26°C and two sizes of *S. glomerata* spat at 25°C. Their study did not investigate the effect of salinity on hatchery-size (<1300 µm) spat.

Salinity and temperature regimes in eastern Australian estuaries used to cultivate *S. glomerata* are dependent upon latitude, season and climatic conditions. *S. glomerata* on the east coast of Australia are cultivated from south eastern Queensland (latitude 27° S) south to the NSW and Victorian border (latitude 37° S) (Nell 2001). Salinity and temperature of estuaries in this geographic region generally range from 0 ppt (fresh) to 38 ppt and 10 to 30°C (Wolf & Collins 1979). As with many other euryhaline aquatic organisms, growth of *S. glomerata* is interdependent on salinity, temperature and available food levels and best growth in adult oysters occurs between 25 and 35 ppt (Holliday 1995).

The measures used to evaluate the effects of temperature and salinity were percentage development of embryos and survival and growth of larvae and spat. Temperature and salinity are two important abiotic factors that affect physiology, stages of development and distribution of oysters (Shumway 1996), particularly when at the larval stage (Devakie & Ali 2000). This study considered the combined impact of salinity and temperature to account for the interactive effects of both factors (Kinne 1964; Lough and Gonor 1973). A number of studies have investigated the combined effects of salinity and temperature, and in some cases additional factors such as metals, nutrition and antibiotics, on early bivalve development using the surface-response technique (O'Connor & Lawler 2004). Surface-response plots were used for this study as they effectively display interactions between salinity and temperature.

4.1.2. Materials and methods

4.1.2.1. General methods

Broodstock were collected from: the Camden Haven River (31° 38' S, 152° 50' E); the Manning River (31° 53' S, 152° 41' E); and, Wagonga Inlet (36° 13' S, 150° 8' E), NSW, Australia. The spawning and fertilisation techniques used for this study are described in O'Connor *et al.* (in press) and each trial conducted used eggs from at least eight females and sperm from at least four males.

Filtered seawater (1 µm nominal, 35 ppt and 25°C) was diluted with deionised water to obtain different salinity levels. Salinity was measured using a calibrated Yeo-Kal 605 Dip Meter (Yeo-Kal

Electronics Pty Ltd, Sydney, Australia). Temperatures were controlled and maintained by inserting 120 ml vials into a thermally insulated aluminium block heated at one end by recirculating heated water and cooled at the opposite end by recirculating chilled water. The test volume for each experiment was 100 ml. Larvae and spat were fed a mixed algal diet of Tahitian *Isochrysis* aff. *galbana*, *Pavlova lutheri* and *Chaetoceros muelleri* daily during the experiments. High concentrations of algal cells were fed so that food availability was not a limiting factor and was adjusted for each experiment according to the size of larvae or spat used.

A complete water exchange was done every second day on all aquaria using filtered seawater that was salinity and temperature adjusted in advance. Embryos, larvae and spat were all fixed in 10% formalin and filtered seawater at the end of experiments.

4.1.2.2. *Measurements*

Light microscopy (X100 magnification) was used to record the number of D-veligers among the first 50 embryos observed from sub-samples collected at 16, 20, 24 and 40 h post fertilisation. The mean percentage of D-veligers was calculated by combining the data from three trials. The mean D-veliger yield was calculated from three trials and was the total number of D-veligers present in a random 5 ml sub-sample collected at 40 h post fertilisation.

Larval and spat survival was determined by recording the number of empty shells observed in a random sub-sample of 100 individuals and expressed as a percentage. The posterior-anterior shell size of fifty surviving larvae and the shell height of fifty surviving spat were measured using a stereomicroscope and an eyepiece graticule (X100 magnification for larvae and X25 magnification for spat). The number of spat that did not have gaping or empty shells were counted and expressed as a proportion of the total number of spat in each treatment in Experiment 5. Spat growth in Experiment 5 was derived from the shell height measurement of all spat that survived during the experiment. To determine percentage settlement (Experiment 4) all spat, including those adhered to the container, larvae as well as dead larvae and spat in the vial were counted using light microscopy.

4.1.2.3. *Experiment 1: The effect of salinity and temperature on embryonic development*

In a fully orthogonal factorial experiment, embryos were exposed to one of 6 salinity levels (10, 15, 20, 25, 30 or 35 ppt) at each of one of 12 temperature levels (16, 18, 20, 21, 22, 23, 24, 25, 26, 27, 28 or 30°C). Each of the 72 vials were stocked with approximately 2000 fertilised eggs (20 fertilised eggs ml⁻¹) and the experiment was repeated three times each using eggs produced from broodstock from the three locations.

4.1.2.4. *Experiment 2: The effect of salinity and temperature on larval survival and growth*

Experiment 2 was a fully orthogonal factorial experiment. Larvae were exposed to one of six test salinities (14, 18, 22, 26, 30 or 34 ppt) at each of one of seven temperatures (16, 19, 21, 23, 25, 28 or 30°C). This experiment was repeated twice and ran for six days. Larvae were exposed to combinations of the above salinities and temperatures at the: D-veliger stage (1 day old and retained on 45 µm mesh); umbonate stage (when larvae were retained on 90 µm mesh after approximately 13 days of larval culture); and, pediveliger or eyed stage (when larvae were retained on 130 µm mesh after approximately 22 days of larval culture). The mean size (± SD) of D-veliger, umbonate and pediveliger larvae at the start of the two trials were: 70.73 ± 1.73 and 71.01 ± 1.73 µm; 144.01 ± 14.14 and 156.96 ± 14.72 µm; and, 238.32 ± 30.32 and 248.86 ± 29.01 µm, correspondingly. Vials were stocked with 5 larvae ml⁻¹ at the D-veliger stage and 2.5 larvae ml⁻¹ at the umbonate and pediveliger stage.

4.1.2.5. *Experiment 3: The influence of salinity and temperature on settlement of larvae*

Approximately 200 eyed pediveliger larvae, 298.13 ± 17.92 (average \pm SD) μm in size, were placed into water at one of four salinities (22, 26, 30 or 34 ppt) each held at 26°C and 30°C for 8 days. Six replicates were included for each salinity level. On each water change (Day 2, 4, 6), the number of metamorphosed spat attached to the walls of the container were counted. On Day 6, larvae were exposed to epinephrine bitartrate (Sigma-Aldrich, product number E1016, CAS number: 51-42-3) at a concentration of 1.8×10^{-4} M for one hour to induce larval settlement (O'Connor *et al.* in press). After the epinephrine bitartrate exposure, vials were left at their respective temperatures and salinities for a further 24 h to allow larval metamorphosis before the experiment ended.

4.1.2.6. *Experiment 4: The effect of salinity and temperature on spat survival and growth*

Experiment 4 was a fully orthogonal factorial experiment. Larvae were exposed to one of six salinities (10, 15, 20, 25, 30 or 35 ppt) at each of one of seven temperatures (16, 19, 21, 23, 25, 28 or 30°C). This experiment was repeated twice and each trial ran for nine days. Vials were stocked with 40 hatchery reared spat with an average shell height (\pm SD) of 1020 ± 169 μm in the first trial and 1159 ± 73 μm in the second trial.

4.1.2.7. *Experiment 5: The effect of salinity on spat survival and growth*

Approximately 1500 hatchery reared spat (943 ± 141 μm mean shell height, mean \pm SD) were placed into 36 aerated aquaria containing 8 L of seawater. Aquaria were placed in a water bath maintained at $25^\circ\text{C} \pm 0.5^\circ\text{C}$. Spat remained in the aquaria for 24 h to acclimate before the salinity of three replicate aquaria was decreased to one of the following twelve salinities: 8; 11; 14; 16; 19; 21; 23; 26; 28; 30; 33, or 34 ± 1 ppt. Rainwater was used to dilute seawater to obtain the required salinity and the duration of this experiment was 17 days. The addition of daily feeds caused very slight salinity increases however the standard deviation of salinity did not exceed 1 ppt in each aquarium.

4.1.2.8. *Data analyses*

To investigate the effect of salinity and temperature on embryo development and survival and growth of larvae and spat, a two factor analysis of variance (ANOVA) was used. Data were arcsine transformed if required for homogeneity of variance. SigmaPlot 2001 Version 7.0 software was used to generate surface-response plots. Two factor ANOVA (fixed factors: temperature and salinity) was used to compare the total number of metamorphosed spat in Experiment 3. Survival and growth data from Experiment 5 were analysed using a one factor (salinity) ANOVA. *Post hoc* pairwise comparisons of results from Experiment 5 were made using Student-Newman-Kuels procedure (Winer 1971) where significant differences ($P < 0.05$) were found.

4.1.3. Results

4.1.3.1. Experiment 1: The effect of salinity and temperature on embryonic development

Development of embryos to D-veliger larvae was significantly affected by temperature ($F = 74.69$; $df\ 11/144$; $P < 0.001$) and salinity ($F = 573.23$; $df\ 5/144$; $P < 0.001$). An interaction between salinity and temperature on the development of embryos to D-veliger larvae was also detected ($F = 13.43$; $df\ 55/144$; $P < 0.001$). Fastest development of embryos to D-veligers occurred at salinities between 30 and 35 ppt and temperatures above 28°C (Figure 1, A.). Maximum development occurred at temperatures above 21°C and salinities above 25 ppt. High rates of development (>80%) occurred at temperatures greater than 30°C. The mean maximum yield was measured at a salinity of 30 ppt and a temperature of 27°C (Figure 1, D). There were very low rates of development (<2%) at temperatures and salinities less than 20°C and 15 ppt, respectively, after 40 h of incubation time (Figure 1, D).

4.1.3.2. Experiment 2: The effect of salinity and temperature on larval survival and growth

Survival of umbonate and pediveliger larvae exceeded 80% over the salinity and temperature combinations tested (Figure 2). Growth of D-veliger, umbonate and pediveliger larvae (Figure 3) was significantly affected by salinity ($F = 82.09$; $df\ 5/42$; $P < 0.001$; $F = 29.47$; $df\ 5/42$; $P < 0.001$; and, $F = 24.35$; $df\ 5/42$; $P < 0.001$, respectively) and temperature ($F = 60.24$; $df\ 6/42$; $P < 0.001$; $F = 47.12$; $df\ 6/42$; $P < 0.001$; and, $F = 69.95$; $df\ 6/42$; $P < 0.001$, respectively) over the ranges examined. There was an interaction between salinity and temperature for both D-veliger ($F = 2.89$; $df\ 30/42$; $P < 0.001$) and umbonate larvae ($F = 1.82$; $df\ 30/42$; $P < 0.05$), however, no interaction between salinity and temperature was detected for pediveliger larvae.

Salinity had a significant effect on D-veliger larval survival ($F = 40.46$; $df\ 5/42$; $P < 0.001$) whilst temperature significantly affected survival of both D-veliger and pediveliger larvae ($F = 22.00$; $df\ 6/42$; $P < 0.001$; and, $F = 6.82$; $df\ 6/42$; $P < 0.001$, respectively). There was an interaction between salinity and temperature for D-veliger larval survival ($F = 9.75$; $df\ 30/42$; $P < 0.001$). Neither salinity nor temperature had a significant effect on survival of umbonate larvae over 6 days within the ranges tested.

The temperature at which the maximum growth occurred for D-veliger larvae was 28°C and was measured at 30°C for both umbonate and pediveliger larvae. Greatest shell size increase for D-veliger and umbonate larvae occurred at the maximum salinity level (34 ppt) (Figure 3, A and B) whereas the salinity at which this occurred for pediveliger larvae was 26 ppt (Figure 3, C). Survival of larvae at these temperature and salinity optima for growth exceeded 90% (Figure 2).

4.1.3.3. Experiment 3: The influence of salinity and temperature on settlement of larvae

Settlement of larvae was significantly affected by temperature ($F = 61.24$; $df\ 1/47$; $P < 0.001$) and, to a lesser extent, salinity ($F = 3.61$; $df\ 3/47$; $P < 0.05$). Additionally, a significant interaction between both factors occurred in this experiment ($F = 3.72$; $df\ 3/47$; $P < 0.05$). Percentage settlement of pediveliger larvae at the four salinities and two temperatures are displayed in Figure 4. This figure also shows the mean proportion of adherent and single seed spat observed in each treatment. Mortalities were limited to larvae and there was no significant difference in the percentage mortality of larvae over the two temperatures ($F = 1.29$; $df\ 1/47$; $P > 0.05$) and four salinities ($F = 1.28$; $df\ 3/47$; $P > 0.05$) tested.

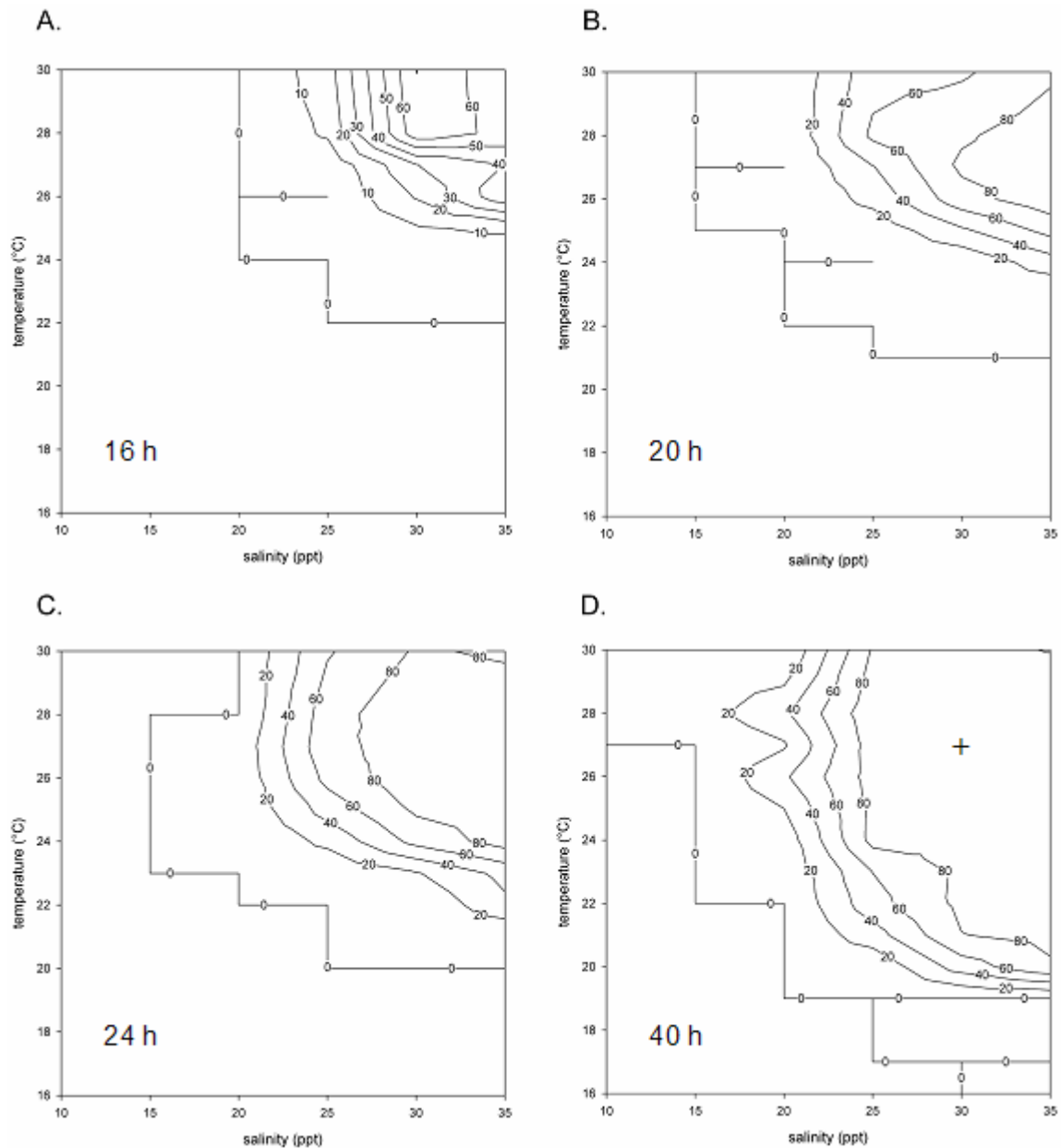

Figure 1. Experiment 1 surface-response plots with isolines estimating the mean percentage of *S. glomerata* embryos to develop to D-veligers after: 16 h (A); 20 h (B); 24 h (C); and, 40 h (D) at a range of temperature and salinity levels. The + symbol on the 40 h plot (D) shows the point of maximum mean yield.

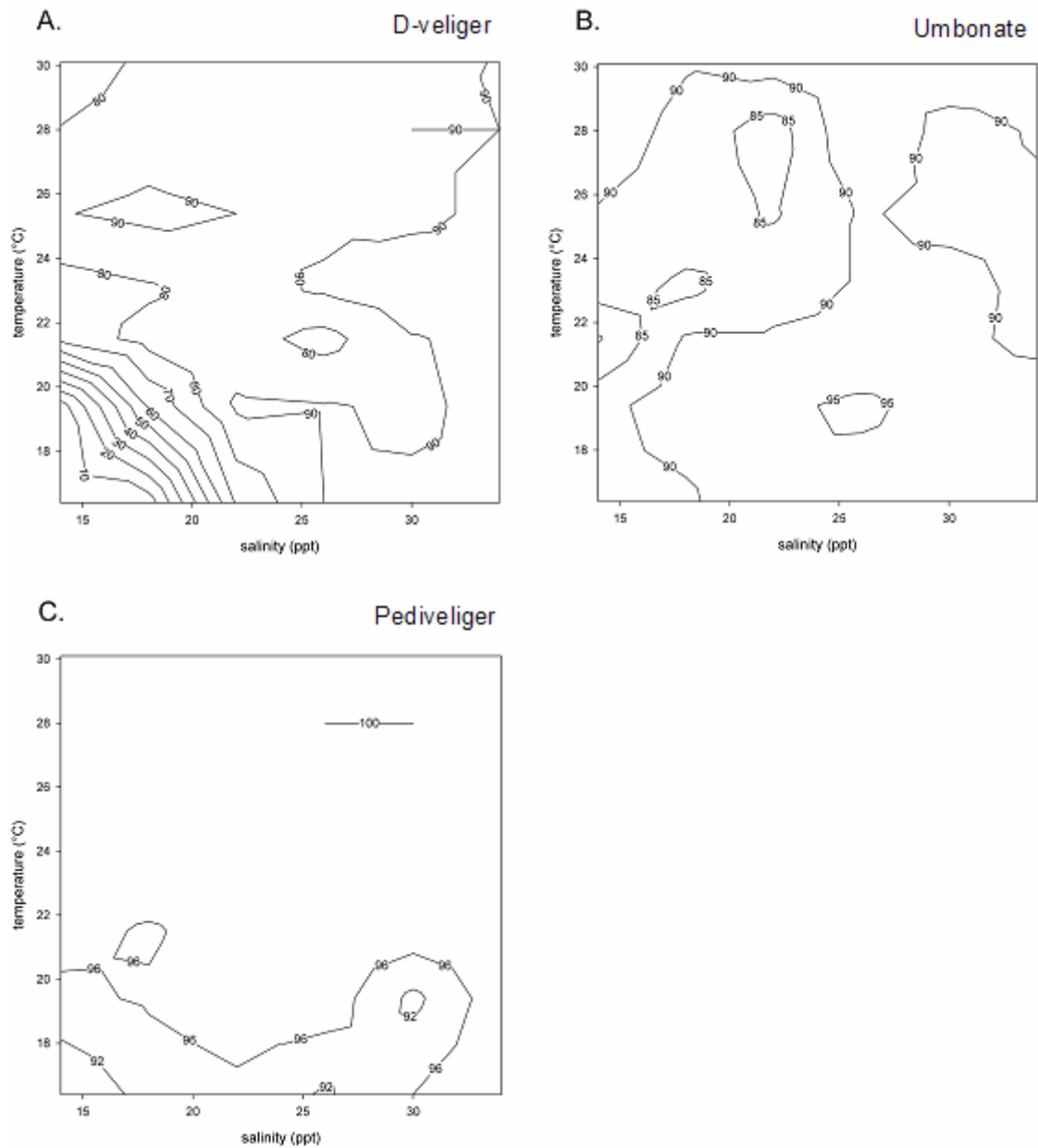

Figure 2. Experiment 2 surface-response plots with isolines estimating the mean percentage survival of *S. glomerata* larvae at: the D-veliger stage (A); umbonate stage (B); and, pediveliger stage (C).

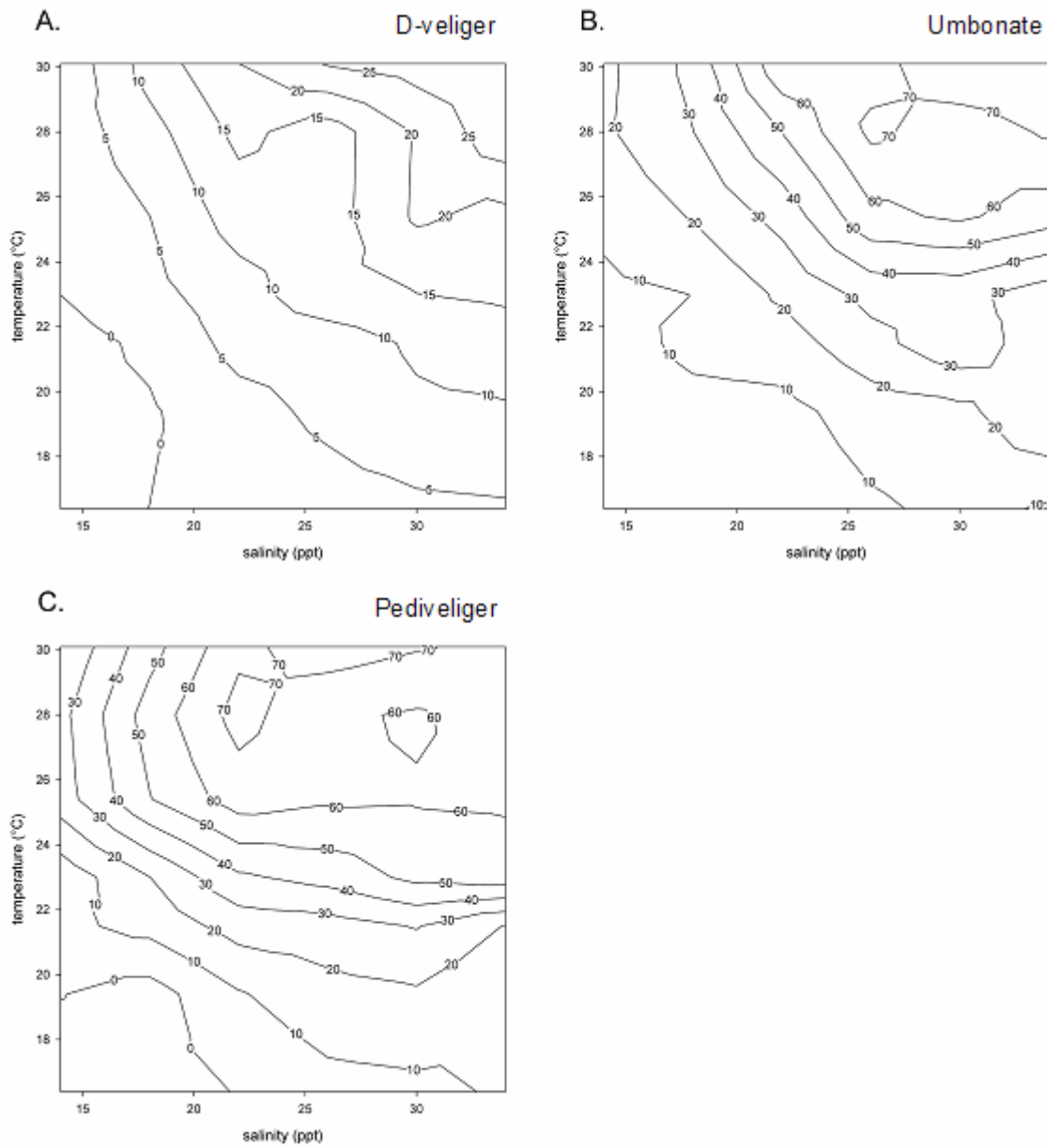

Figure 3. Experiment 2 surface-response plots with isolines estimating the mean growth increase (μm) of *S. glomerata* larvae at: the D-veliger stage (A); umbonate stage (B); and, pediveliger stage (C).

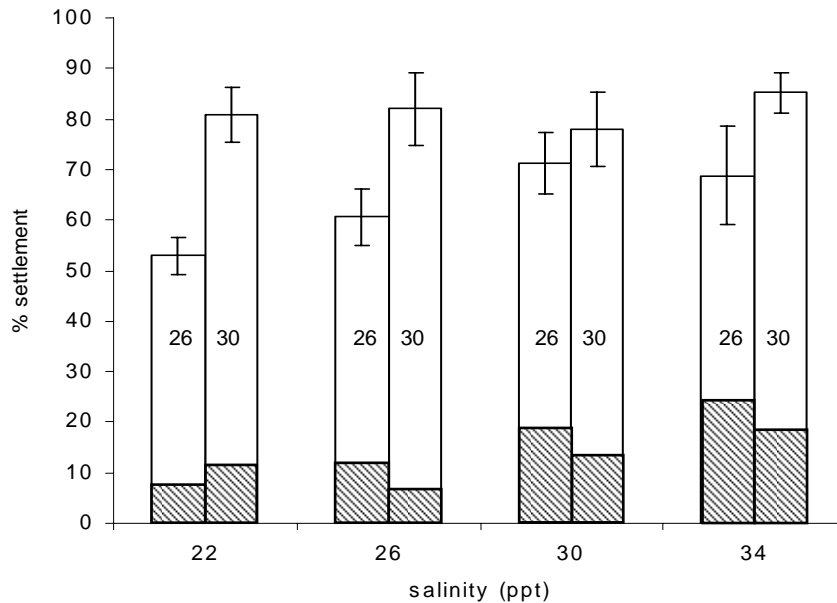

Figure 4. Mean percentage settlement at 26 and 30°C and at four salinities (Experiment 3). The hashed and white components of columns indicate the proportion of spat adhered to the vial and single seed spat, respectively. Error bars show the 95% confidence intervals.

4.1.3.4. Experiment 4: The combined effect of salinity and temperature on spat survival and growth

Spat survival was significantly affected by salinity only ($F = 28.27$; $df\ 5/42$; $P < 0.001$) (Figure 5). However, spat growth was significantly affected by salinity ($F = 19.72$; $df\ 5/42$; $P < 0.001$) and temperature ($F = 9.83$; $df\ 6/42$; $P < 0.001$) (Figure 6). No interaction was detected between these two factors for spat survival and growth. Optimal salinity and temperature for spat growth was measured to be 30°C and 35 ppt (Figure 6). At this salinity and temperature combination, survival was 80% (Figure 5). Maximum spat survival was 93% and was at a lower temperature and salinity combination of 23°C and 30 ppt, correspondingly (Figure 5).

4.1.3.5. Experiment 5: The effect of salinity on spat survival and growth

Figure 7 shows survival of spat at 25°C was significantly influenced by salinity ($F = 135.94$; $df\ 11/35$; $P < 0.001$). The optimal salinity range for survival of spat was 21 to 33 ppt. Survival of spat was very low (<10%) at salinities below 16 ppt and steadily increased from 60% to 74% between 19 ppt and 28 ppt. However, further increases in salinity to 34 ppt significantly reduced survival. Overall, spat survival was lower than expected which was attributed to a spat mortality event before the experiment.

The growth increments for spat at 25°C at the different salinity levels tested are shown in Figure 8. Spat growth was not measured at salinities below 19 ppt because of high mortalities in these treatments (Figure 7). Spat growth was significantly influenced by salinity ($F = 38.85$; $df\ 7/23$; $P < 0.001$) and growth increased incrementally with salinity from 19 ppt up to 34 ppt (Figure 8). Best growth increases were measured at salinities above 26 ppt with the maximum occurring at 34 ppt (Figure 8).

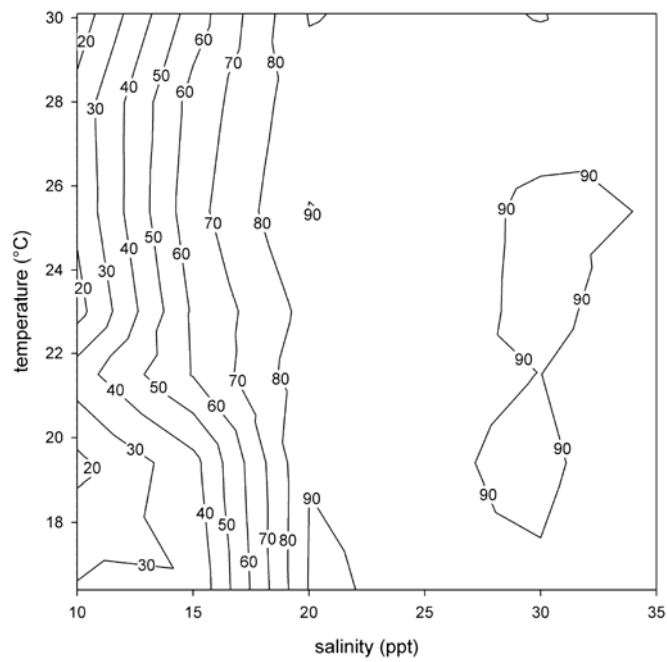

Figure 5. Experiment 4 surface-response plot with isolines estimating the mean percentage survival of *S. glomerata* spat.

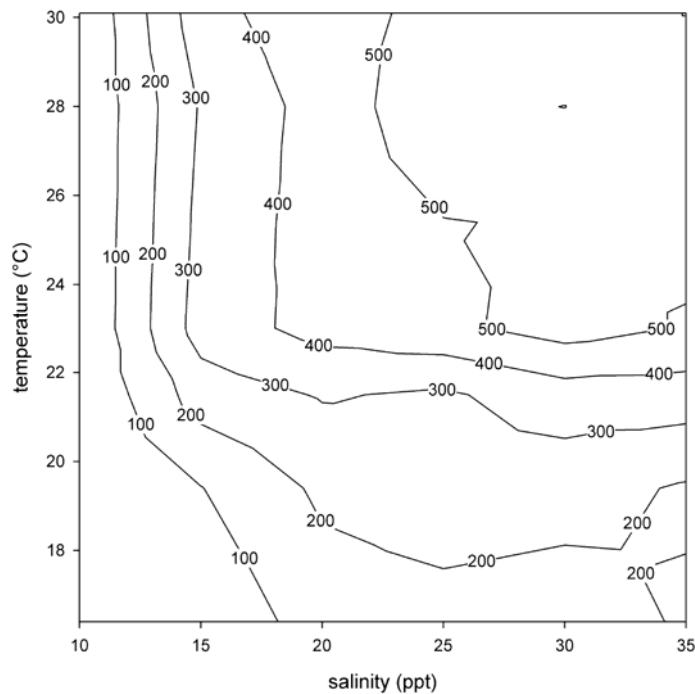

Figure 6. Experiment 4 surface-response plot with isolines estimating the mean growth increase of *S. glomerata* spat.

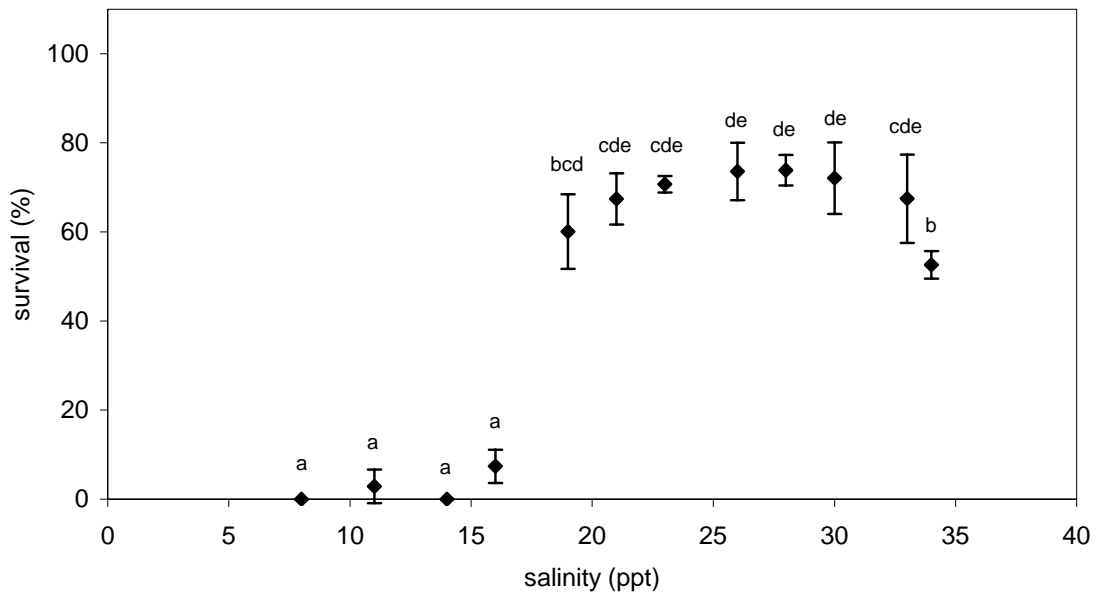

Figure 7. Mean percentage survival of *S. glomerata* spat at 12 salinity levels (Experiment 5). Post hoc results are displayed as letters indicating means which are not significantly different ($P > 0.05$). Error bars display the 95% confidence intervals ($n = 3$).

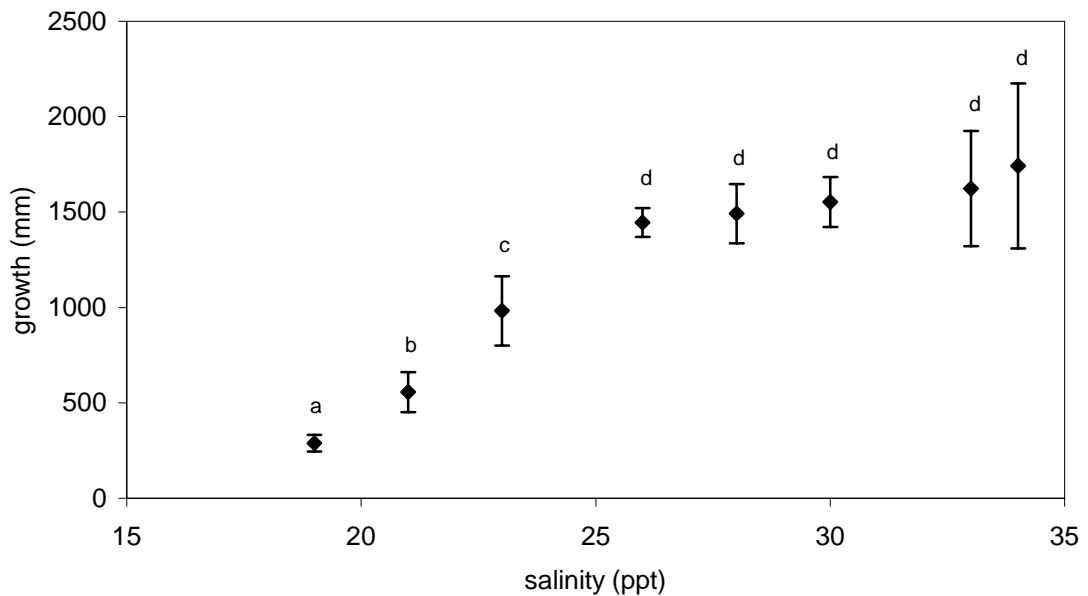

Figure 8. Mean growth increase of *S. glomerata* spat over the 17 day experimental period (Experiment 5). Post hoc results are displayed as letters indicating means which are not significantly different ($P > 0.05$). Error bars display the 95% confidence intervals ($n = 3$). Mean growth of spat below 19 ppt are not displayed.

4.1.4. Discussion

4.1.4.1. Embryos

Temperature and salinity acted synergistically to affect the rate of embryonic development and control the proportion of embryos that developed to the D-veliger stage (Figure 1). However, the upper limit at which temperature and salinity impact embryonic development was above the levels tested in this present study.

Embryos could not tolerate salinities below 24 ppt and no development occurred at temperatures less than 19°C. Most development occurred at salinities above 25 ppt and temperatures over 24°C with the maximum mean yield recorded at a salinity and temperature combination of 35 ppt and 26°C. This result corresponds to recommended levels for larval rearing of *S. glomerata* reported by Frankish *et al.* (1991). Embryos were very sensitive to temperature decreases, particularly when temperature fell below 20°C.

O'Connor and Lawler (2004) investigated salinity and temperature tolerance for pearl oyster (*Pinctada imbricata*) embryos and juveniles using the same measures of impact and similar temperature and salinity ranges. *P. imbricata* embryos had a low tolerance of salinities less than 29 ppt and temperatures below 17°C (O'Connor & Lawler 2004). Although *P. imbricata* could withstand slightly lower water temperatures compared to *S. glomerata* embryos, the latter were more tolerable of salinity reductions. Populations of *P. imbricata* occur over a broader geographical range compared to *S. glomerata* (O'Connor *et al.* 2003). At particular locations along the southern Queensland and NSW coastline, both species are cultivated in the same estuarine systems, however *P. imbricata* cultivation generally occurs closer to the estuary mouth and in areas that are not impacted by freshwater inflows (O'Connor *et al.* 2003). Similarly, wild populations of *P. imbricata* are more commonly found in close proximity to the estuary mouth and in coastal locations where salinity remains similar to oceanic levels (O'Connor & Lawler 2004), whereas wild populations of *S. glomerata* generally extend from the estuary mouth to further upstream into areas with variable salinities (Nell 1993).

4.1.4.2. Larvae

Temperature and salinity also acted synergistically to impact growth and survival of D-veliger larvae and growth of umbonate larvae. High rates of survival were recorded for umbonate and pediveliger larvae across all salinity and temperature ranges tested (Figure 2, C). There were clear ontogenetic changes in tolerance between embryos and D-veliger larvae as well as ontogenetic changes through the larval phase with greater tolerance of both salinity and temperature evident as larval development occurred. This is particularly the case between D-veliger larvae and umbonate larvae. D-veliger tolerance to temperatures and salinities below than 21°C and 22 ppt dramatically decreased (Figure 2, A).

Temperature significantly affected the growth of pediveliger larvae with temperatures above 26°C resulting in the best growth rates, particularly at salinities above 20 ppt. The greatest increases in length of larvae occurred at the maximum salinity level for D-veliger and umbonate larvae. However, the maximum length increase for pediveliger larvae was measured at a slightly lower salinity (26 ppt). The optimal temperature for growth of D-veliger larvae was measured at 28°C and was 30°C for pediveliger larvae.

In a different study, *S. glomerata* D-veliger larvae had highest growth rates at salinities of 23 – 39 ppt and highest survival rate at salinities between 27 – 39 ppt at 26°C (Nell & Holliday 1988). Nell

and Holliday (1988) also determined that Pacific oyster (*Crassostrea gigas*) D-veliger larvae survive well through the salinity range of 15 to 39 ppt at 26°C, although best growth was measured at salinities between 19 and 27 ppt. *C. gigas* larvae prefer lower salinities compared to *S. glomerata* which was observed in Port Stephens where the predominance of *C. gigas* wild populations are in upstream areas (Nell & Holliday 1988). In the estuarine environment, hydrological factors following spawning of adults cause *S. glomerata* larvae to be carried downstream towards the estuary mouth by currents (Nell 1993). Hence, the predominance of natural populations of *S. glomerata* occur in the lower reaches of estuarine systems.

His *et al.* (1989) found that *C. gigas* larvae survived over a wide temperature and salinity range and determined that temperature had a greater effect than salinity. Their study also investigated the effect of nutrition and found that larvae can survive for about one week over a wide temperature (15 to 30°C) and salinity (20 to 30 ppt) range (His *et al.* 1989). These findings are consistent with results obtained for survival of *S. glomerata* larvae (Figure 2).

Information obtained from Experiment 2 indicated that larval settlement occurred earlier at the higher temperatures and salinities tested. Experiment 3 compared the present *S. glomerata* larval rearing temperature of 26°C to 30°C over the range of salinities that resulted in the good pediveliger growth rates (22 to 34 ppt). This was done to determine if the percentage settlement could be elevated. Increasing the rearing temperature by 4°C at the pediveliger stage increased the proportion of larvae that metamorphosed into spat. At 26°C, the salinity of the water impacted settlement, whereas at 30°C settlement was very consistent over the four salinities tested (Figure 4). Increasing the proportion of larval set in commercial batches has many benefits for bivalve hatcheries and this result will be further investigated by the authors at the commercial level.

4.1.4.3. Spat

Salinity controlled survival and survival levels improved when salinity was above 20 ppt at all the temperatures tested (Figure 5) when the combined effect of salinity and temperature on spat was examined. This result highlights an ontogenetic change with respect to temperature and salinity tolerance between larvae and spat. Umbonate and pediveliger larvae are able to withstand greater ranges in salinity compared to spat. Growth in spat improved incrementally as both temperature and salinity increased. The optimal salinity and temperature combination for spat growth was found to be at 35 ppt and 30°C, however, a lower level of survival was recorded at these levels (82 %) compared to slightly lower salinities and temperatures. In contrast, the maximum spat survival of 93% was measured at 23°C and 30 ppt salinity.

The effect of salinity at 25°C on spat survival was investigated in Experiment 5. Hatchery rearing of *S. glomerata* spat is conducted at 25°C to achieve a compromise between survival, growth and the cost of production. Experiment 5 used similar equipment and rearing techniques that are used to produce commercial quantities of *S. glomerata* spat. This experiment also allowed for more salinity levels to be tested and greater replication. At 25°C spat were not able to survive for 17 days in salinities below 19 ppt and best growth increases occurred when the salinity was higher than 26 ppt.

Nell and Holliday (1988) determined the optimal salinity to rear small (1.3 mg) and large (0.61 g) *S. glomerata* and *C. gigas* spat. Their study differed from this research in four main ways: larger spat were used; the effect of salinity on umbonate and pediveliger larvae was not examined; synergistic effects were not investigated; and, survival and growth of *S. glomerata* was compared to *C. gigas*. Small *S. glomerata* spat used in Nell and Holliday's (1988) study had the fastest growth at salinity levels between 25 and 35 ppt and large spat (0.61 g) had the fastest growth rates at salinity levels between 20 and 40 ppt. Small *C. gigas* spat grew best at salinities between 15 – 30, but larger *C. gigas* spat grew at a uniform rate across all salinities tested (15 – 45 ppt). Spat

survival for both species was not affected by salinity within the range of 15 to 40 ppt (Nell & Holliday 1988). As both species became more developed, the salinity range for good growth and survival widened (Nell & Holliday 1988).

4.1.4.4. Implications for early rearing

Controlled laboratory experiments are an effective way to determine the combined effects of salinity and temperature on the biology of oyster larvae and spat. This study was primarily undertaken to improve larval survival through optimising conditions for early rearing of *S. glomerata* in the hatchery environment. In addition to this, the study also provides information on the ecology of *S. glomerata* relevant to the estuarine environment. The study included the later larval stages and newly settled spat to develop the most favourable hatchery rearing conditions throughout its early ontogeny. The optimal levels derived for each ontogenetic stage are summarised in Table 1.

Table 1. Optimal salinity and temperature for survival and growth of *S. glomerata*.

Ontogenetic stage	Exp. no.	Survival			Growth	
		Optimal salinity (ppt)	Optimal temperature (°C)	Mean survival* (%)	Optimal salinity (ppt)	Optimal temperature (°C)
Embryo development	1	35	26	-	-	-
D-veliger larvae	2	30	23	96 ± 1.0	34	28
Umbonate larvae	2	26	19	96 ± 3.9	34	30
Pediveliger larvae	2	26-34	25-28	100	26	30
Spat (1090 µm)	4	30	23	97 ± 9.3	35	30

* ± the 95% confidence interval

Hatcheries can manipulate temperature and salinity levels to enhance larval and spat survival and growth performance as well as increasing settlement rates. Using the optimal salinity and temperature levels at different stages can increase yield and growth, thereby reducing the time taken to complete the hatchery rearing phase. However, commercial hatcheries operate under various economic constraints and managers should consider the additional costs associated with providing optimal conditions, such as increasing rearing temperature.

Geographic location is another factor that can influence salinity and temperature tolerance of larvae and spat and should be considered by hatcheries producing this species in areas other than NSW. *S. glomerata* are held in the hatchery until spat reach a size of between 800 – 1000 µm (retained on 500 µm mesh). At this size spat are transported to field-based nursery upwellers. In these systems, estuarine water is pumped through a land-based or floating tank making it very difficult to control temperature and salinity. Most estuaries where *S. glomerata* are farmed are impacted by freshwater

inflows after heavy rainfall that can lower estuarine salinities to <10 ppt for many weeks. This study highlighted how susceptible small spat are to salinities less than 20 ppt. Knowledge of the temperature and salinity ranges that spat can withstand allows operators to monitor these factors and investigate relocating stock if either factor, particularly salinity, is below acceptable levels.

Fundamental knowledge of salinity and temperature requirements of *S. glomerata* is necessary for reliable cost-effective commercial hatchery production. Experiments from this study have determined the lower limits at which salinity and temperature impact growth and survival of *S. glomerata* embryos, larvae and spat. Additionally, optimal combinations of salinity and temperature were identified to elevate embryonic development plus larval and spat survival and growth during the hatchery rearing phase.

4.1.5. References

- Dove, M.C. & W.A. O'Connor. 2007. Ecotoxicological evaluations of common hatchery substances and procedures used in the production of Sydney rock oysters *Saccostrea glomerata* (Gould 1850). *J. Shellfish Res.* 26.
- Frankish, K.R., L.J. Goard & W.A. O'Connor. 1991. The development of hatchery rearing techniques of the Sydney rock oyster (*Saccostrea commercialis*) at the Brackish Water Fish Culture Research Station, Salamander Bay, NSW, 2301. 26 pp.
- Heasman, M.P., L. Goard, J. Diemar & R.B. Callinan. 2000. Improved early survival of molluscs: Sydney rock oyster (*Saccostrea glomerata*). NSW Fisheries Final Report Series: 29. Nelson Bay. 63 pp.
- His, E., R. Robert & A. Dinet. 1989. Combined effects of temperature and salinity on fed and starved larvae of the Mediterranean mussel *Mytilus galloprovincialis* and the Japanese oyster *Crassostrea gigas*. *Marine Biology* 100:455–463.
- Holliday, J.E. 1995. Nursery Culture of Sydney Rock Oysters, *Saccostrea commercialis* (Iredale and Roughley, 1933) and Pacific Oysters *Crassostrea gigas* (Thunberg, 1793). Unpublished PHD Thesis, Department of Aquaculture, University of Tasmania.
- Kinne, O. 1964. The effects of temperature and salinity on marine and brackish water animals: II. Salinity and temperature-salinity combinations. *Oceanography and Marine Biology: Annual Reviews* 2:281–339.
- Lough, R.G. & J.J. Gonor. 1973. A response-surface approach to the combined effects of temperature and salinity on larval development of *Adula californiensis* (Pelecypoda: Mytilidae). I Survival and growth of three and fifteen-day old larvae. *Marine Biology* 22:241–250.
- Nell, J.A. 1993. Farming the Sydney Rock Oyster (*Saccostrea commercialis*) in Australia. *Reviews in Fisheries Science* 1:97–120.
- Nell, J.A. 2001. The history of oyster farming in Australia. *Marine Fisheries Review* 63:14–25.
- Nell, J.A. & B. Perkins. 2005. Evaluation of progeny of fourth generation Sydney rock oyster *Saccostrea glomerata* (Gould 1850) breeding lines. *Aquaculture Research* 36:753–757.
- Nell, J.A. & B. Perkins. 2006. Evaluation of the progeny of third-generation Sydney rock oyster *Saccostrea glomerata* (Gould 1850) breeding lines for resistance to QX disease *Marteilia sydneyi* and winter mortality *Bonamia roughleyi*. *Aquaculture Research* 37:693–700.
- Nell, J.A. & J.E. Holliday. 1988. Effects of salinity on growth and survival of Sydney rock oyster (*Saccostrea commercialis*) and Pacific oyster larvae and spat. *Aquaculture* 68:39–44.
- NSW Department of Primary Industries. 2004. Aquaculture Production Report 2003/2004. NSW Department of Primary Industries, Port Stephens Fisheries Centre. 20pp.
- O'Connor, W.A. & N.F. Lawler. 2004. Salinity and temperature tolerance of embryos and juveniles of the pearl oyster, *Pinctada imbricata* Roding. *Aquaculture* 229:493–506.

- O'Connor, W.A., N.F. Lawler & M.P. Heasman. 2003. Trial farming of the akoya pearl oyster, *Pinctada imbricata*, in Port Stephens, NSW. NSW Fisheries Final Report Series: 42. Nelson Bay. 170 pp.
- O'Connor, W.A. *et al.* (in press). Hatchery Manual for Sydney rock oysters, *Saccostrea glomerata*. NSW DPI Final Report Series. Nelson Bay.
- Shumway, S.E. 1996. Natural Environmental Factors. In V.S. Kennedy, R.I.E. Newell and A.F. Eble (Eds.) *The Eastern Oyster, Crassostrea virginica*. Maryland Sea Grant College, University of Maryland System, College Park. pp 467–503.
- White, I. 2002. 'Safeguarding Environmental Conditions for Oyster Cultivation in New South Wales.' Report (Number 010801) for the NSW Healthy Rivers Commission.
- Winer, B.J. 1971. *Statistical Principles in Experimental Design*. McGraw-Hill, New York, NY. Pp 205–210.
- Wolf, P.H. & A.J. Collins. 1979. Summary of Daily Temperatures and Salinity Records for Major Oyster-Bearing Estuaries of New South Wales 1966 – 1973. NSW State Fisheries. Sydney, N.S.W. 107 pp

4.2. Ecotoxicological evaluations of common hatchery substances and procedures used in the production of Sydney rock oysters *Saccostrea glomerata*

4.2.1. Introduction

Hatchery production of *Saccostrea glomerata* commenced in the early 1980s but has been plagued by recurrent mass mortality syndromes in both larvae and spat. In a review of hatchery production attempts for *S. glomerata* between 1985 and 1990, Heasman *et al.* (2000) found 57% of larval runs failed within eight days of fertilisation. The inability to produce commercial quantities of selectively bred spat in the past has prevented industry gaining the benefits of genetic research. To overcome hatchery failures, a systematic research and development program was carried out. A component of this program was to investigate toxic agents and stressful handling procedures that could potentially cause larval mortality.

Oyster embryos are sensitive and vulnerable to a range of pollutants, particularly trace metals (Wisely and Blick 1967; Calabrese *et al.* 1973; Calabrese *et al.* 1977; Martin *et al.* 1981; Wilson and Hyne 1997). Also, seawater and freshwater supplies for hatcheries can become contaminated in a number of ways by many factors related to materials, design or location as well as the origin of the water or the presence of deleterious microflora. Moreover, toxins that cause hatchery problems can be difficult to identify and temporal (Jones 2003).

Cleaning and disinfection of water, tanks, equipment and facilities used for rearing bivalves is performed by filtration, desiccation and chemical application processes and is common practice in shellfish hatcheries to maintain hygiene. Problems can arise when small amounts of chemicals unintentionally find their way into rearing tanks, particularly tanks used for early larval culture. Handling procedures also have the potential to impact embryos either through physical damage, air exposure or dramatic temperature and salinity fluctuations. For example, physical damage may occur when eggs and sperm are screened through fine PVC mesh (20 – 80 µm) to remove debris and faeces collected from the spawning table.

This study evaluated the chronic toxicity of substances commonly used in oyster hatcheries and the effect of egg screening on embryonic development of *S. glomerata*. Substances to which embryos or larvae could be inadvertently or accidentally exposed were tested for toxicity in preliminary trials. These substances and their usage are listed in Table 1. Particular substances found to be toxic were then classified as “high” risk and subjected to more rigorous ecotoxicological testing. The impacts of Virkon S and Virkon S for Aquaculture (virucidal disinfectants, Antec International Limited, Suffolk, UK) as well as chlorine to *S. glomerata* embryos were quantified. Other contaminants that could impact on larval development were investigated and included: rainwater; bore water, and algal culture media used in bivalve hatcheries.

4.2.2. Materials and methods

4.2.2.1. Spawning

S. glomerata embryos for the preliminary range finding tests were obtained from broodstock collected from the Manning River (31° 53' S, 152° 41' E) and spawned on 2 June 2004. Embryos for the definitive tests were obtained from two spawning inductions, the first on 17 August 2004 and the second on 24 August 2004. Broodstock for the definitive tests were from Port Stephens (32° 11' S, 152° 20' E) and Wagonga Inlet (36° 13' S, 150° 8' E) and were collected on the 28 June 2004 and 27 July 2004, respectively.

Table 1. Details of hatchery substances and the procedure tested in preliminary range finding tests on *S. glomerata* embryos.

Substance/Procedure	Applications	Suggested Concentration	Type of Hatchery	Risk of Impact*
Sodium hypochlorite (chlorine)	Sterilisation of tanks, plumbing, equipment, clothes and seawater	¹ 30 mg available chlorine L ⁻¹ for sterilising clean surfaces and in water ¹ 50 mg available chlorine L ⁻¹ for pipelines, tanks, equipment, effluent water, clothing and footbaths (exposure time > 30 minutes)	Bivalve, fish & crustacean	High
Iodine (Iodophors)	Sterilisation of external surfaces of bivalve broodstock, footwear, equipment, hands and laboratory surfaces	¹ 200-250 mg iodine L ⁻¹ (for 10 minutes) for pipelines, tanks, equipment, clothing	Bivalve, fish & crustacean	Low
Potassium permanganate	Sterilisation of equipment	² Approximately 25 g L ⁻¹	Bivalve	Low
Virkon® S & Virkon® S for Aquaculture	Sterilisation and cleaning of tanks	³ 5 g L ⁻¹ for cleaning and disinfecting non-porous surfaces	Bivalve, fish & crustacean	High
Antec Cleaning and Sanitizing Agent (DSC-1000)	Sterilisation and cleaning of tanks	³ 1:1000 dilution for cleaning purposes 1:100 to 1:800 for biocidal treatments	Bivalve, fish & crustacean	Low
Pyroneg	Cleaning of equipment	⁴ 2-3 g L ⁻¹ in warm water	Bivalve, fish & crustacean	Low
Sodium thiosulfate	Neutralisation of chlorine and iodine	¹ 2.85 times the amount of residual chlorine (grams), and 0.78 times the amount of iodine (grams) used	Bivalve, fish & crustacean	Low
Rainwater	Cleaning, rinsing and dilution of seawater for salinity reduction	⁵ Up to 90% rainwater in seawater for larval experiments	PSFC bivalve hatchery	High
Bore water	Cleaning, rinsing and dilution of seawater for salinity reduction	⁵ Up to 90% bore water in seawater for larval experiments	PSFC bivalve hatchery	High
Algal supernatant	Food for larvae	⁵ 0.1 to 0.2% of algal mixture added to larval tanks in the first 48 h of culture	PSFC bivalve hatchery	High
Egg screening	Egg screening to rinse, separate or remove faeces and debris from spawning	⁵ 1-3 passes of eggs through a 20 µm to 65 µm mesh screen	PSFC bivalve hatchery	High

* to larvae under present practices used at the PSFC bivalve hatchery

¹ OIE Manual (2003)

² Sigma Pharmaceuticals Pty Limited, Clayton, Victoria, Australia

³ Antec International Limited, Suffolk, UK

⁴ JohnsonDiversey Australia Pty Limited, Smithfield, NSW, Australia

⁵ Concentration currently used at the PSFC bivalve hatchery

Thirty adult broodstock oysters were used for each spawning. Oysters were scrubbed to remove mud, cleaned of fouling organisms and held at the Port Stephens Fisheries Centre (PSFC) bivalve hatchery in a conditioning unit at 25°C and 34 ppt before each test. The *S. glomerata* embryos for tests were obtained using thermal stimulation and salinity fluctuations in natural seawater (22°C, 33 ppt and filtered to 1 µm) following the spawning procedure described in Frankish *et al.* (1991). This procedure was used in favour of physically stripping gametes from the gonads of oysters as it reduces the possibility of using under-developed gametes in experimental treatments (His *et al.* 1997).

Oysters releasing gametes were placed into separate 500 ml plastic containers partially filled with seawater (22°C, 33 ppt and filtered to 1 µm). Eggs from at least six females were pooled, passed through a 55 µm screen to remove debris and then placed into a 1 L plastic beaker for each test. The number of eggs was estimated using a Sedgewick-Rafter counting chamber and fertilised with simultaneously released sperm from at least three males for each test. The egg and sperm suspension was left for another 20 minutes while fertilisation occurred and then stocked into the test vessels.

4.2.2.2. Embryo development tests

A static 48 h larval abnormality test was used. Tests were conducted according to methods and procedures described in ASTM (1994) and Krassoi *et al.* (1996). A series of range finding tests were conducted initially using the substances and procedures listed in Table 1. The information from these tests was then used to design and carry out three definitive tests which had five replicates per treatment. The test control and diluent water was natural seawater that had a salinity level of 34 ± 0.5 ppt and was filtered to 1 µm. Daylight and a fluorescent lighting (<1000 lux) were used to maintain a photoperiod of 16 h of light and 8 h of darkness over the experimental period. Test vessels were 120 ml polypropylene vials that contained 100 ml of test solution after the toxicant and larvae were added. Temperature, pH, dissolved oxygen concentration and salinity of additional treatments were measured at the start and conclusion of the experiment. Fertilised eggs were added at a density of 20 eggs ml⁻¹ to each test chamber using an automatic pipette. This egg density was lower than the egg density used by Krassoi (1995) (100 eggs ml⁻¹) and is not known to cause abnormality. Test chambers were randomly placed in a temperature controlled incubator chamber at $25 \pm 0.5^\circ\text{C}$ immediately after fertilised eggs were added. Fertilisation rate was verified using light microscopy (X250 magnification) on an additional test chamber removed from the experiment after 3 h.

The test parameter was the proportion of abnormalities at the D-veliger stage. Most *S. glomerata* embryos have reached D-veliger stage after 20 h incubation time at 34 ppt salinity and 25°C. Tests were however continued for 48 h before 0.8 ml of 10% buffered formalin was added to each test unit to halt development. Normal D-veliger larvae are characterised by a straight hinge and symmetrical shell plates. Larvae were considered abnormal if they were deformed, had misshapen or asymmetrical shell plates or had not progressed past the trochophore or blastophore stage (undeveloped) after 48 h had elapsed (Krassoi 1995; Krassoi *et al.* 1996; His *et al.* 1997). Typical examples of normal straight-hinge larvae, abnormal larvae and an undeveloped larva are displayed in Fig. 1. A total of 100 larvae (5%) from each test unit were randomly selected and examined for the percentage of D-veliger development using light microscopy (X100 magnification).

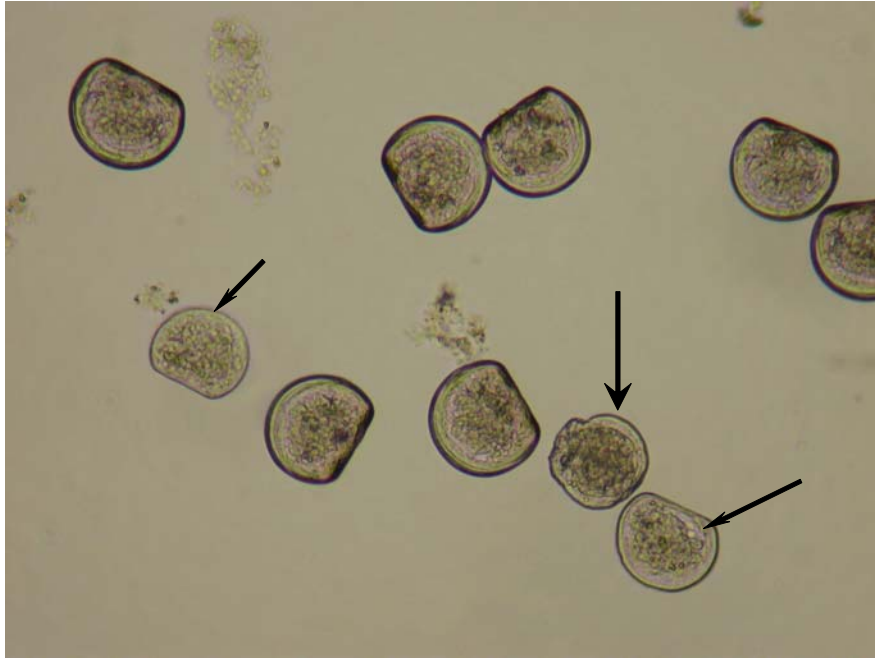

Figure 1. Micrograph of abnormal (small arrows), undeveloped (large arrow) and normal (others) *Saccostrea glomerata* D-veliger larvae from 1% rainwater treatment at 48 h post fertilisation. (X250 magnification).

4.2.2.3. Toxicants

The preliminary range finding tests evaluated the substances and egg screening procedure listed in Table 1. The exposure levels used in these tests for each substance or procedure are recorded in Table 2. The substances classified as “high” risk (Table 1) and found to have a toxic effect at plausible concentrations for contamination of rearing tanks were then selected for the definitive test and included: rainwater; bore water; chlorine; Virkon S; and, algal supernatant. Concentrations were adjusted for the definitive test based on results from the preliminary test so that no abnormal development occurred in the lowest concentration and 100% abnormal development occurred at the highest concentration. The toxicity Virkon S for Aquaculture, a virucidal disinfectant for aquacultural applications, to *S. glomerata* was evaluated at a later date (1 May 2006) as this product was not in use when the definitive tests were done. The concentrations of toxicants tested in the definitive test are listed in Table 3. Deionised water was used to make stock solutions of Virkon S and Virkon S for Aquaculture to add to the test vessels. Algal supernatant was prepared by combining Tahitian *Isochrysis* aff. *galbana*, *Pavlova lutheri* and *Chaetoceros calcitrans* in the proportions that are fed to *S. glomerata* D-veliger larvae (1:1:2, dry weight) and placing the mixture in a centrifuge before decanting the supernatant. Additionally, deionised water was included in the definitive test at the same concentrations as bore water and rainwater to examine osmotic effects from decreased salinity levels on embryo development. Handling procedures were also of concern and the effect of repeated screening of fertilised eggs was tested. Fertilised eggs were passed through a 55 µm mesh screen 4, 8 and 16 times before stocking into the test chambers.

Table 2. Preliminary range finding test exposure levels and proportion of abnormal development.

Substance/Procedure	Units	Concentrations	Abnormal Development (%)
Sodium hypochlorite (chlorine)	mg L ⁻¹	0.002	15
		0.21	11
		2.08	92
Iodine (Iodophors)	mg L ⁻¹	0.0003	9
		0.03	12
		0.3	13
Potassium permanganate	mg L ⁻¹	0.0002	14
		0.02	22
		0.2	63
Antec Virkon® S	mg L ⁻¹	0.5	69
		50	97
		500	100
Antec Cleaning and Sanitising Agent (DSC-1000)	-	1:1000000	39
		1:10000	100
Pyroneg	mg L ⁻¹	0.15	32
		15.3	100
Sodium thiosulfate	mg L ⁻¹	0.0006	28
		0.06	26
		0.63	100
Deionised water	%	0.01	8
		1	4
		10	7
Rainwater	%	0.01	9
		1	75
		10	100
Bore water	%	0.01	11
		1	16
		10	98
Algal supernatant	%	0.01	10
		1	8
		10	15
		50	66
Egg screening (No. of repetitions)	No. of repetitions	1	8
		4	8
		8	17

Table 3. Definitive toxicity test results for *S. glomerata* embryos exposed to substances commonly used for larval rearing at the PSFC bivalve hatchery. The mean (\pm 95% confidence interval, $n = 3$) proportion abnormal development for the control treatment was 1.8 ± 1.5 %.

Toxicant	Concentrations	Date	Test	EC ₅₀ (95% CL)	LOEC	NOEC
Rainwater (%)	0, 0.01, 0.1, 1, 10	17 Aug 2004	1	0.67 (0.53-0.86)	1	0.1
		24 Aug 2004	2	2.29 (1.88-2.77)	1	0.1
		24 Aug 2004	3	1.55 (1.24-1.94)	1	0.1
Bore water (%)	0, 0.01, 0.1, 1, 10	17 Aug 2004	1	3.70 (3.29-4.15)	10	1
		24 Aug 2004	2	2.30 (1.93-2.75)	10	1
		24 Aug 2004	3	2.9 (2.44-3.45)	10	1
Algal supernatant (%)	0, 0.1, 1, 10, 20, 40	17 Aug 2004	1	17.80 (16.64-19.03)	20	10
		24 Aug 2004	2	17.43 (14.60-20.80)	20	10
		24 Aug 2004	3	6.51 (5.26-8.06)	10	1
Chlorine (mg L ⁻¹)	0, 0.002, 0.02, 0.21, 0.42, 0.83, 1.66, 2.08	17 Aug 2004	1	0.76 (0.69-0.84)	0.83	0.42
		24 Aug 2004	2	1.11 (1.04-1.18)	1.66	0.83
		24 Aug 2004	3	1.18 (1.09-1.28)	1.66	0.83
Virkon® S (mg L ⁻¹)	0, 0.05, 0.5, 5, 50	17 Aug 2004	1	0.47 (0.35-0.63)	0.5	0.05
		24 Aug 2004	2	0.58 (0.43-0.79)	0.5	0.05
		24 Aug 2004	3	0.65 (0.42-1.02)	0.05	0
		1 May 2006	4	0.91 (0.74-1.13)	0.5	0.05
		1 May 2006	5	1.01 (0.80-1.28)	0.05	0
Virkon® S for Aquaculture (mg L ⁻¹)	0, 0.05, 0.5, 5, 50	1 May 2006	1	1.12 (0.92-1.37)	0.5	0.05
		1 May 2006	2	0.99 (0.80-1.21)	0.5	0.05

4.2.2.4. Data analyses

The proportion of abnormal larvae was determined for all tests conducted. The mean % abnormal development data were calculated by combining data from the five replicate treatments within each of the three definitive tests and these data were corrected for the pooled percentage abnormality in the control treatments. The EC₅₀ value and the 95% confidence intervals were calculated using the trimmed Spearman Karber method (Hamilton *et al.* 1977) on corrected abnormality data for the tests involving rainwater, chlorine, Virkon S, Virkon S for Aquaculture, bore water and algal supernatant. Proportion larval abnormality data were arcsine transformed and analysed using Analysis of Variance (ANOVA) and Dunnett's test to determine the no observable effect concentration (NOEC) and lowest observable effect concentration (LOEC) following Bartlett's test for homogeneity of variance. The Dunnett Program Version 1.5 computer program obtained from Environmental Monitoring Systems Laboratory, United States Environmental Protection Agency was used to perform these analyses.

4.2.3. Results

The water quality variables of pH, electrical conductivity, dissolved oxygen concentration and temperature remained static in the test chambers during the test period. However, adding Virkon S, Virkon S for Aquaculture, deionised water, rainwater and bore water altered diluent water quality. The addition of Virkon S and Virkon S for Aquaculture caused the pH of the test chambers to decrease by 0.4 units when added at a concentration of 50 mg L⁻¹. Deionised water, rainwater and bore water caused a decrease of 4.3 dS m⁻¹ in the electrical conductivity over the concentrations tested (0 – 10%) but did not alter the pH compared to the control treatment.

The proportion of abnormal larval development determined from preliminary testing is listed in Table 2. These results indicate that chlorine, potassium permanganate, Virkon S, Antec Cleaning and Sanitising Agent (DSC-1000), Pyroneg, sodium thiosulfate, rainwater, bore water, algal supernatant and egg screening have the potential to impact *S. glomerata* development.

The acute toxicities of substances in the definitive test that impact on *S. glomerata* embryonic development are listed in Table 3. Embryonic development of *S. glomerata* when exposed to rainwater, bore water, deionised water, algal supernatant, chlorine, Virkon S, Virkon S for Aquaculture or repeated screening are displayed in Fig. 2. Rainwater was investigated over the range of 0.01 to 10% in seawater. The LOEC for rainwater used in this study was 1% and the EC₅₀ value was estimated to be between 0.67 and 2.29%. Bore water was investigated over the same concentration range as rainwater and had a lesser impact on embryonic development compared to rainwater. The LOEC and EC₅₀ range for bore water was 10% and 2.30 to 3.70%, respectively. Heterogeneity of variances was detected using Bartlett's test in Test 3 for rainwater and bore water. Tests 1 and 2 had homogenous variances and provided the same LOEC and NOEC levels as Test 3 for both toxicants.

To test for osmotic effects from decreased salinity levels on embryo development, deionised water was tested at concentrations of 0.01, 0.1, 1 and 10% in seawater. ANOVA did not detect a significant difference in embryonic development across the four concentrations in the three tests ($F = 0.428$; $df = 4/10$; $P > 0.05$). Likewise, screening of fertilised eggs was found to not have a significant effect on embryonic development ($F = 1.651$; $df = 3/8$; $P > 0.05$). Fig. 2 shows the proportion of abnormally developed larvae exposed to deionised water and larvae that were exposed to repeated screening of fertilised eggs.

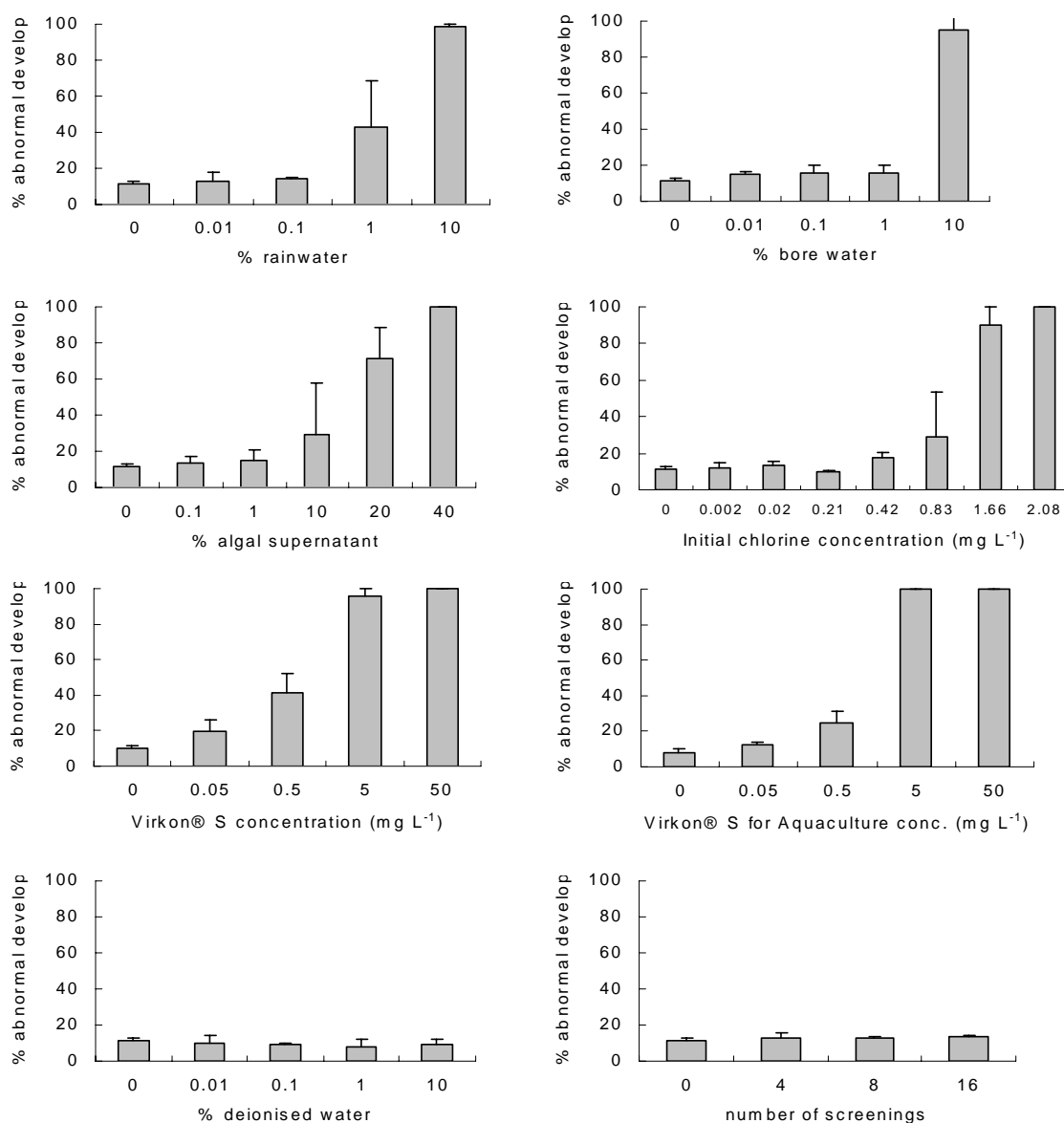

Figure 2. *S. glomerata* embryonic development after 48 h exposure to various hatchery toxicants, deionised water or following repeated screening of fertilised eggs. Values displayed are the means \pm 95% confidence intervals calculated over the total number of tests conducted for each substance/procedure.

The EC₅₀ value estimated for algal supernatant ranged between 6.51 and 17.80%. The LOEC and NOEC levels for algal supernatant were different in the third test from the first two tests conducted. The LOEC level was 20% in Tests 1 and 2 and 10% in Test 3. The NOEC in test 3 was 1%, however it was estimated to be 10% in the first two tests. The NOEC result from the third test was 1% and is much greater than the concentration of algal mixture typically added to an incubation tank. Heterogeneity of variances was detected in the third test.

S. glomerata embryo development was inhibited when exposed to treatments containing chlorine. No development to the D-veliger larval stage occurred at an initial concentration of 2.08 mg L⁻¹ in the three tests (Fig. 2). Chlorine levels at initial concentrations of 0.83 mg L⁻¹ in Test 1 and 1.66

mg L⁻¹ in Tests 2 and 3 were observed to have a significant ($P < 0.05$) effect on embryonic development. The range of the estimated EC₅₀ value was from 0.76 to 1.18 mg L⁻¹ for the three tests. Likewise, Virkon S caused significant ($P < 0.05$) levels of abnormal development in *S. glomerata* embryos at a concentration of 0.05 mg L⁻¹ in tests 3 and 5 and 0.5 mg L⁻¹ in tests 1, 2 and 4. The LOEC and NOEC determined for Virkon S for Aquaculture in both tests conducted was 0.5 mg L⁻¹ and 0.05 mg L⁻¹, respectively. Concentrations of Virkon S and Virkon S for Aquaculture in seawater above 50 mg L⁻¹ prevented all embryos developing to the D-veliger larval stage (Fig. 2). Heterogeneity of variances were detected in the data used for Tests 1 and 3 for chlorine, Tests 1 and 4 for Virkon S and Test 1 for Virkon S for Aquaculture. However, these results are comparable to tests where there was equality of variances according to Bartlett's test.

4.2.4. Discussion

A range of pollutants can cause problems to larval batches in hatcheries, including: metals; disinfectants; surfactants; hydrocarbons; endocrine disruptors; and antibiotics (Jones 2003). Generally, these substances are accidentally or inadvertently introduced to larval cultures, however given the various pathways that contaminants can enter hatcheries, great care is required.

Virkon S and chlorine solutions can both be used for cleaning and disinfection of larval rearing equipment. Virkon S is a virucidal disinfectant that contains potassium peroxomonosulphate, sulphamic acid and sodium alkyl benzene sulphonate. Virkon S is used at a concentration of 5 g L⁻¹ and is applied to tanks used for larval and spat rearing (Table 1) between water changes, conducted on alternate days. There is negligible information available on the toxicity of Virkon S to aquatic organisms in the literature. One investigation of the toxicity of Virkon S to post larval (15 day old) giant tiger prawns and adult giant tiger prawns determined the LC₅₀ for this substance to be 10.31 mg L⁻¹ and 120.33 mg L⁻¹, respectively and all post larval prawns were dead after exposure to 50 mg L⁻¹ for 5 h (Suphamat 2005).

Small concentrations of Virkon S or chlorine have a significant effect on embryonic development. In the case of Virkon S, catastrophic contamination of incubation tanks can occur through careless use or failure to rinse the chemical residue away following application. Approximately 500 ml of Virkon S prepared at the recommended concentration (Table 1) is applied to clean a 1,000 L incubation tank before fertilised eggs are added and between regular water changes during larval rearing. If the tank was not properly rinsed, the concentration of Virkon S could be as high as 2.5 mg L⁻¹ which could prevent more than 80% of *S. glomerata* embryos from developing to the D-veliger stage. This level of non-development is not acceptable for research or production runs where generally more than 95% of *S. glomerata* embryos develop into D-veliger larvae.

Tests conducted on 1 May 2006 showed that Virkon S for Aquaculture and Virkon S impacted *S. glomerata* development in a similar way. The constituents of Virkon S for Aquaculture are different from Virkon S and are pentapotassium bis(peroxymonosulphate) bis(sulphate), sulphamidic acid, sodium dodecylbenzenesulfonate and dipotassium peroxidisulphate. Both products are virucidal disinfectants and are used for the same applications in a hatchery environment (Table 1).

Applied as sodium hypochlorite (LR), chlorine is used at a concentration of between 30 and 50 mg L⁻¹ to clean and disinfect larval rearing equipment. Chlorine must also be carefully handled in areas where oysters are spawned and where larvae are incubated. It is also important that any equipment cleaned using chlorine, particularly screens, be thoroughly rinsed before coming into contact with eggs or embryos. Ideally, the use of solutions containing chlorine should be restricted to areas of the hatchery isolated from areas used to rear larvae to minimise the risk of accidental contamination. Furthermore, neutralisation of chlorine with thiosulfate also can pose a potential

hazard. The preliminary tests conducted for this study indicated that thiosulfate could restrict *S. glomerata* development.

Stewart *et al.* (1979), Roosenburg *et al.* (1980) and Richardson *et al.* (1982) investigated the effects of chlorination on *Crassostrea virginica* larvae. These studies were conducted to investigate pollution of the natural environment by chlorinated discharges originating from industrial and sewage sources and identified impacts to larval development as a result of exposure to chlorinated waters. In addition to this, residual oxidants from chlorinated seawater are also particularly toxic to oyster larvae (Stewart *et al.* 1979; Roosenburg *et al.* 1980) and other aquatic organisms and should always be neutralised before release from hatchery facilities (OIE 2003).

Contamination may also occur due to hatchery design, location or materials used in construction (Jones 2003). Stored water sources used in hatcheries can be contaminated at a number of different points. Contamination can occur during collection of the water, during transport or pumping of water to a storage tank, in the tank itself and in the pipes that deliver the water to the hatchery.

The PSFC bivalve hatchery is reliant on stored rainwater or bore water for freshwater, which is used for rinsing, cleaning and to dilute seawater, predominately for experiments conducted within the hatchery. Both rainwater and bore water are supplied to the hatchery through copper pipe plumbing. The quality of the rainwater supply to the hatchery is highly variable and dependent on antecedent rainfall, storage time and the amount of interaction with organic matter accumulated on the roof catchment and in the storage tanks. Likewise, the quality of bore water can also be influenced by climatic factors, chemical treatment and the mineralogy of the aquifer's sediments.

The rainwater and bore water used for this study caused significant impacts to larvae at relatively low concentrations; levels as low as 1% rainwater in seawater caused a significant decrease in embryonic development. Rainwater is often used to decrease salinity levels to induce oysters to spawn. Bore water was the only feasible alternative to rainwater to reduce salinities for spawning. Bore water was found to be less toxic than rainwater to *S. glomerata* embryos, however, it still caused significant reductions in development at a concentration of 10% added to seawater.

The quality of rainwater and bore water is likely to vary considerably over time, however, data from this study showed that the impacts were similar on different test dates. The toxicity of the freshwater at the study location may affect experiment results, particularly those from long-term studies. Treatments that used deionised water in the same concentrations as bore water and rainwater did not significantly affect embryonic development. The low abnormal development rates in treatments that contained rainwater and bore water can be attributed to contaminants contained within those waters and not due to osmotic effects caused by a decreased salinity level. Rainwater had elevated levels of Cu, Mg, Na, S and Zn whilst bore water had elevated levels of Ca, Cu, K, Mg, Na, Si, S, and Zn compared to the deionised water samples (Table 4). Therefore, deionised water is recommended for reducing the salinity of seawater, particularly for embryo and larval rearing.

Table 4. Chemical analysis* results of seawater (diluent), deionised water, bore water and rainwater samples collected at the PSFC bivalve hatchery.

Ion	Detection limits (mg L ⁻¹)	Seawater (diluent) (mg L ⁻¹)	Deionised water (mg L ⁻¹)	Bore water (mg L ⁻¹)	Rainwater (mg L ⁻¹)
Al	0.070	bd	bd	bd	bd
As	0.006	bd	0.02	0.01	0.02
B	0.006	bd	bd	0.05	bd
Ba	0.001	0.01	0.01	0.02	0.02
Ca	0.147	413.62	0.20	2.93	0.83
Cd	0.096	bd	bd	bd	bd
Co	0.082	bd	bd	bd	bd
Cr	0.035	bd	bd	bd	bd
Cu	0.001	0.07	0.03	0.34	0.25
Fe	0.001	0.01	bd	bd	bd
K	0.024	410.21	0.32	4.50	0.94
Li	0.006	0.17	bd	bd	bd
Mg	0.004	1311.30	0.03	4.94	1.38
Mn	0.016	bd	bd	bd	bd
Na	0.000	11254.26	0.44	135.49	11.79
Ni	0.002	bd	bd	bd	bd
P	0.009	bd	bd	bd	bd
Pb	0.241	bd	bd	bd	bd
Sb	0.261	bd	bd	bd	bd
Si	0.048	bd	bd	2.08	bd
S	0.050	1096.18	0.07	25.07	1.45
Sr	0.049	7.59	bd	bd	bd
Ti	1.984	bd	bd	bd	bd
Zn	0.024	0.05	bd	0.27	2.59

* samples filtered through 0.22 µm cellulose nitrate filter paper and analysed using Inductively Coupled Plasma Atomic Excitation Spectroscopy (model Perkin Elmer Optima 3000 DV)
bd = below detection limit

Algal mixtures typically consisting of Tahitian *Isochrysis* aff. *galbana*, *Pavlova lutheri* and *Chaetoceros calcitrans* are not commonly added to tanks containing fertilised eggs until the majority have developed to D-veliger. Regardless, these mixtures can contain low concentrations of trace metals or toxic metabolites, or if bacterised, toxins that can affect larval survival and growth (Calabrese & Davis 1970). Thus their impact on embryos was tested as an indicator of potential effects on D-veliger growth and survival.

Algal mixtures fed to larvae within the 48 h post fertilisation were tested to ensure it did not inhibit development at the concentrations added for daily feeds. Approximately 2 L of algal mixture is added to incubation tanks within the initial 24 h after fertilisation as a food source for rapidly developing larvae. This equates to a concentration of 0.2% algal suspension in seawater in a 1000 L incubation tank. The data from this study showed that this concentration did not affect embryonic development.

Handling procedures of *S. glomerata* eggs were also of concern and the effect of screening fertilised eggs was included in this study to ensure this process did not physically damage eggs. Eggs are typically screened through a 55 µm screen prior to or after sperm have been added, to remove faeces and debris accumulated during spawning. Screening eggs through a 55 µm mesh did not affect embryonic development.

As oysters spawn they are removed from the aquarium and placed into separate containers that hold seawater at ~ 34 ppt and 25°C (Frankish *et al.* 1991). The temperature on the spawning table varies up to 10°C during cycles and could be up to 6°C different to the container. Also, during spawning

induction, the salinity level of the aquarium is decreased from 34 ppt to 20 – 24 ppt. Salinity and temperature shocks of this magnitude may impact *S. glomerata* eggs and sperm and further handling experiments are planned to investigate the effect on early larval development of temperature shocks that may occur following spawning.

The study was conducted to: maximise larval yields; increase awareness amongst hatchery staff of the risks posed by various substances frequently used in hatcheries; and, to establish a method for examining new substances, materials and handling procedures introduced to the hatchery. Toxicity testing conducted for this study has identified several risk factors that have the potential to negatively affect the early larval development of *S. glomerata*.

4.2.5. **References**

- A.S.T.M. 1994. E 724-94. Standard guide for conducting static acute toxicity tests starting with embryos of four species of saltwater bivalve molluscs. In: Pesticides; Resource Recovery; Hazardous Substances and Oil Spill Responses; Waste Disposal; Biological Effects, Volume 11.04, American Society for Testing and Materials, Philadelphia. pp 192–209.
- Calabrese, A. & H.C. Davis. 1970. Tolerances and requirements of embryos and larvae of bivalve molluscs. *Helgolander wiss. Meeresunters* 20:553–564.
- Calabrese, A., J.R. MacInnes, D.A. Nelson & J.E. Miller. 1977. Survival and growth of bivalve larvae under heavy-metal stress. *Marine Biology* 41:179–184.
- Calabrese, A., R.S. Collier, D.A. Nelson & J.R. MacInnes. 1973. The toxicity of heavy metals to embryos of the American oyster *Crassostrea virginica*. *Marine Biology* 18:162–166.
- Frankish, K.R., L.J. Goard & W.A. O'Connor. 1991. The development of hatchery rearing techniques of the Sydney rock oyster (*Saccostrea commercialis*) at the Brackish Water Fish Culture Research Station, Salamander Bay, NSW, 2301. 26 pp.
- Hamilton, M.A., R.C. Russo & R.V. Thurston. 1977. Trimmed Spearman-Kärber method for estimating median lethal concentrations in toxicity bioassays. *Environmental Science and Technology* 11:714–719. Correction in *Environmental Science and Technology* 12:417.
- Heasman, M.P., L. Goard, J. Diemar & R.B. Callinan. 2000. Improved early survival of molluscs: Sydney rock oyster (*Saccostrea glomerata*). NSW Fisheries Final Report Series: 29. Nelson Bay. 63 pp.
- His, E., M.N.L. Seaman & R. Beiras. 1997. A simplification the bivalve embryogenesis and larval development bioassay method for water quality assessment. *Water Research* 31:351–355.
- Jones, B. 2003. Review of hygiene, equipment and protocols. In: M.P. Heasman, editor. Proceedings, Sydney Rock Oyster Hatchery Health Workshop, 8 – 9 August, 2002. NSW Fisheries Research Report Series: 61. Nelson Bay. pp. 45–49.
- Krassoi, R. 1995. Salinity adjustment of effluents for use with marine bioassays: effects on the larvae of the doughboy scallop *Chlamys asperrimus* and the Sydney Rock Oyster *Saccostrea commercialis*. *Australasian Journal of Ecotoxicology* 1:143–148.
- Krassoi, R., D. Everett & I. Anderson. 1996. Protocol for using doughboy scallop *Chlamys asperrima* (Mollusca: Pectinidae) L. to test the sublethal toxicity of single compounds and effluents. National Pulp Mills Research Program Technical Report No. 17. Canberra: CSIRO. 56 pp.
- Martin, M., K.E. Osborn, P. Billig & N. Glickstein. 1981. Toxicities of ten metals to *Crassostrea gigas* and *Mytilus edulis* embryos and *Cancer magister* larvae. *Marine Pollution Bulletin* 12:305–308.
- Nell, J.A. 1993. Farming the Sydney Rock Oyster (*Saccostrea commercialis*) in Australia. *Reviews in Fisheries Science* 1:97–120.

- Nell, J.A. & B. Perkins. 2005. Evaluation of progeny of fourth generation Sydney rock oyster *Saccostrea glomerata* (Gould 1850) breeding lines. *Aquaculture Research* 36:753–757.
- Nell, J.A. & B. Perkins. 2006. Evaluation of the progeny of third-generation Sydney rock oyster *Saccostrea glomerata* (Gould 1850) breeding lines for resistance to QX disease *Marteilia sydneyi* and winter mortality *Bonamia roughleyi*. *Aquaculture Research* 37:693–700.
- NSW Department of Primary Industries. 2004. Aquaculture Production Report 2003/2004. NSW Department of Primary Industries, Port Stephens Fisheries Centre. 20 pp.
- O.I.E. 2003. Manual of diagnostic tests for aquatic animals 2003. Paris, France: The World Organisation of Animal Health (Office International des Epizooties).
- Richardson, L.B., D.T. Burton & A.M. Stavola. 1982. A comparison of ozone and chlorine toxicity to three life stages of the American oyster *Crassostrea virginica*. *Marine Environmental Research* 6:99–113.
- Roosenburg, W.H., J.C. Rhoderick, R.M. Block, V.S. Kennedy, S.R. Gullans, S.M. Vreenegoor, A. Rosenkranz & C. Collette. 1980. Effects of chlorine-produced oxidants on survival of larvae of the oyster *Crassostrea virginica*. *Marine Ecology Progress Series* 3:93–96.
- Stewart, M.E., W.J. Blogoslawski, R.Y. Hsu & G.R. Helz. 1979. By-products of oxidative biocides: toxicity to oyster larvae. *Marine Pollution Bulletin* 10:166–169.
- Suphamat, K. 2005. Research into the levels of toxicity of Virkon® S which affect giant tiger prawns at different stages. <http://www.antecint.co.uk/main/prawntox.htm>. Accessed December 2005.
- White, I. 2002. Safeguarding environmental conditions for oyster cultivation in New South Wales. Report (Number 010801) for the NSW Healthy Rivers Commission. Sydney. 84 pp.
- Wilson, S.P. & R.V. Hyne. 1997. Toxicity of acid-sulfate soil leachate and aluminium to embryos of the Sydney rock oyster. *Ecotoxicology and Environmental Safety* 37:30–36.
- Wisely, B. & R.A.P. Blick. 1967. Mortality of marine invertebrate larvae in mercury, copper, and zinc solutions. *Australian Journal of Marine and Freshwater Research* 18:63–72.

4.3. Ontogenetic variation in dietary preferences of Sydney rock oyster, *Saccostrea glomerata*, larvae and spat

4.3.1. Introduction

Both biologically and economically it is important to select the best available diets for the propagation of bivalve species. Despite the development of various dietary alternatives, such as yeast, bacteria and microcapsules (Nell, 1993; Coutteau and Sorgeloos, 1992), the majority of hatcheries continue to choose their diets from among a number microalgal species. The cost of providing these microalgal diets has been estimated to be between 30 – 50% of the cost of spat production (Holliday, 1985; Coutteau and Sorgeloos, 1992).

Many studies have been conducted to assess the nutritional value of a variety of algal species as a food source for bivalve larvae and spat (Walne, 1970; Enright *et al.*, 1986; Laing and Millican, 1986). While certain alga have been found to produce good spat growth with a variety of bivalves, others, such as *Dunaliella tertiolecta* Butcher have consistently performed poorly (Walne, 1970; Langdon and Waldock, 1981; Enright *et al.*, 1986). A variety of factors are involved in determining the food value of a particular alga to bivalves, including cell size, digestibility and lack of toxicity (Webb and Chu, 1983). Variability also stems from factors including differences in algal culture conditions (Utting, 1985; Harrison *et al.*, 1990; Thompson *et al.*, 1993), algal culture growth phase at harvest (Whyte *et al.*, 1989), and from the dietary contribution of dissolved organic material and naturally occurring phytoplankton, yeast and bacteria (Manahan, 1990; Jaeckle and Manahan, 1992; Alber and Valiela, 1996).

Previously the dietary preferences of both larvae and spat of *S. glomerata* have been determined (Nell and O'Connor, 1991; O'Connor *et al.*, 1992) and a change in preferences has been highlighted. It was thought that this change could be associated with metamorphosis and the resultant change in feeding mechanisms. Accordingly, ternary diets of *Chaetoceros calcitrans* Pavlova lutheri and Tahitian *Isochrysis* aff. *galbana* were fed to larvae and following metamorphosis, *C. calcitrans* was gradually replaced with *Chaetoceros muelleri*. (Frankish *et al.*, 1991; Heasman *et al.*, 2002).

Unfortunately, while large batches of several million SROs have been produced in hatcheries in NSW, the techniques have not been sufficiently reliable to be adopted commercially. Previously this has not been critical as spat has been readily available from the wild, but the recent breeding of lines of *S. glomerata* that are capable of significantly faster growth and great disease resistance (Nell *et al.*, 1991) is dependent on reliable hatchery production for industry supply. Two problems have plagued hatchery production: (1) Larval anorexia or starvation has affected many hatchery production runs and occurs when the oysters are between 2 to 8 days old; (2) Spat mortality occurs later when the oysters are approximately 1 week – 1.5 months old and are being held in nursery systems outside the hatchery.

As part of a larger, more comprehensive investigation of factors that could impact on the success of *S. glomerata* spat production, the approximate timing of the change in dietary preferences was determined. As a product of these trials larval diets have been altered to include the phased introduction of *C. muelleri* as the larvae enter the umbonate stage approximately 8 – 9 days after fertilisation.

4.3.2. *Materials and methods*

4.3.2.1. *Algal culture techniques*

Axenic algal cultures were produced in aerated (1 – 2% CO₂ enriched) 10-l polycarbonate carboys. All species were grown from cultures provided by the CSIRO, Hobart, Tasmania, and were batch cultured in seawater (salinity 35 – 37 g kg⁻¹) at 21±1°C. The nutrient medium, f/2 beta (Guillard, 1983), was used with Na₂SiO₃·5H₂O added to diatom cultures only. Cultures were illuminated with “White, Wattsaver” fluorescent tubes (Osram, Sydney, Australia) to an intensity of 4000 Lux at the container surface using a 16:8 h light:dark cycle. Cultures were harvested during exponential growth phase and a minimum of three cultures of each species was used during each experiment. Algal cell dry weights were taken from Nell and O'Connor (1991) and O'Connor *et al.* (1992). Samples of the carboy cultures were collected and proximate analyses of Protein, Carbohydrate, and lipids, as well as fatty acid composition were determined.

4.3.2.2. *Experimental oysters*

One hundred *S. glomerata* were collected from Port Stephens, NSW, and induced to spawn using temperature and salinity cues (Frankish *et al.*, 1991). To assist in ensuring genetic diversity, batches of eggs from more than 30 oysters were fertilized with sperm collected from over 15 males. The resultant embryos were pooled and placed in 20 000 L and cultured using techniques based on those described by Frankish *et al.* (1991). The larvae were fed *C. calcitrans* *P. lutheri* and Tahitian *Isochrysis* aff. *galbana* until metamorphosis, when the *C. calcitrans* was replaced with *C. muelleri*.

4.3.2.3. *Larval dietary preferences*

Three experiments were conducted with larvae were drawn from the 20 000 L on three occasions; Experiment 1 at 24 h when the larvae were 65.3 ± 1.8 µm, Experiment 2 after 5 days when the larvae were 92.4 ± 3.8 µm and Experiment 3 after 10 days when the larvae were 127.8 ± 14.5 µm. Each experiment ran for seven days and on each occasion sufficient oysters were taken to stock 28, 500 mL flasks at density of 5 larvae mL⁻¹ into 150 mL of seawater. Flasks were held in a temperature controlled, orbital shaker incubator (60 rpm, 26°C). Culture water in all experiments was changed every 48 h, with the larvae being retained on a 45 µm nylon mesh screen. Temperature equilibrated oceanic seawater (35 g kg⁻¹) was filtered using 1 µm (nominal) cartridge filters before use to reduce the background level of potential food items in the water. In each experiment, four replicate flasks of larvae were fed one of six algal diets (Table 1).

The feeding rate used in each larval trial was based on the rate of consumption of the larvae in the 20,000 L tank and assumed that in each experimental replicate there was no mortality or losses and that the experimental larvae were growing at the same rate as the commercial scale batch. Since neither of these assumptions was true (some mortality occurred and growth was slower than in the 20,000 L tank), feeding at this rate ensured that food quantity to the experimental larvae was not limiting to growth. An additional four replicate flasks remained unfed for the duration of each experiment.

4.3.2.4. Spat dietary preferences

Nine-day-old spat ($1167 \pm 67 \mu\text{m}$) were collected and groups of 50 were placed on nylon mesh screens in miniature downweller systems housed in separate 8 L aerated aquarium (Fig. 1). The oceanic water (35 ‰) used in each aquarium was filtered using $1 \mu\text{m}$ nominal cartridge filters to reduce the levels of suspended solids. Each aquarium was maintained at $24 \pm 1^\circ\text{C}$ and the water changed every three days.

For each experiment the daily feed ration was determined according to the equation $Q_R = 0.01W^{0.33}$, where Q_R is dry weight (g) of ration/live weight of bivalve (g) and W is the live weight of bivalve (g) (Epifanio, 1979).

At the completion of each trial (larval and spat), oysters were fixed in seawater containing formalin (4% vol.). The growth of 30 oysters per replicate was determined using a microscope (100x magnification) and an ocular micrometer ($\pm 2.5 \mu\text{m}$). Estimates of survival were obtained from the number of dead oysters (empty shells or shells containing necrotic tissue) encountered during the measurement of 30 oysters and was expressed as a percentage. The spat experiment (Experiment 4, Table 1) ran for 10 days, after which the spat were removed from each downweller and weighed as a group to the nearest mg. Fifty spat were then chosen at random from each replicate and using a binocular microscope with an eyepiece micrometer, their shell heights (dorso-ventral measurement) and shell lengths (antero-posterior measurement) were determined to the nearest $20 \mu\text{m}$. The spat were then returned to their respective replicate groups and dried for 24 h at 100°C before their dry weights determined to the nearest mg.

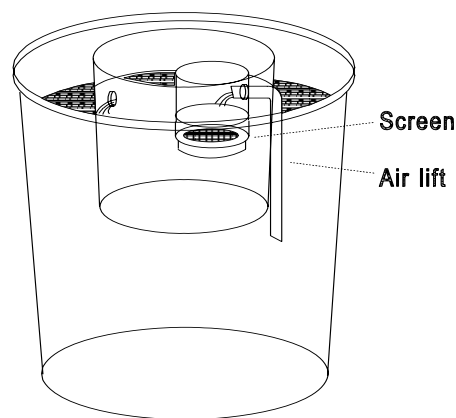

Figure 1. Experimental downwelling system used for spat culture.

4.3.2.5. Statistical analysis

Prior to analysis, homogeneity of variance was confirmed in each case using Cochran's test (Winer, 1971). Larval percentage survival data was $\arcsin x^{0.5}$ transformed (Sokal and Rohlf, 1981). Data from each experiment was then analysed with single-factor analysis of variance and, where significant differences were found, mean values were compared using Student Newman Kuels procedure (Winer *et al.*, 1971).

4.3.3. Results

4.3.3.1. Larval dietary preferences

Significant differences ($P < 0.001$) in both growth of *S. glomerata* larvae and spat were observed following treatment with various algal species in each successive experiment (Table 1). In larval Experiment 1, commencing with 1-day-old larvae, the greatest growth occurred in treatments fed a ternary diet of *P. lutheri*, *T. Iso* and *C. calcitrans*, although this growth was not significantly greater than either of the alternate ternary diets tested. In this experiment, no significant differences in growth were found between unfed larvae and the mono-specific diets tested and all were inferior diets to the ternary diets tested. \

In Experiment 2, commencing with 5-day-old larvae, there was a change in the best performing diet which saw treatments fed with a ternary diet including *C. muelleri*, grow significantly ($P < 0.001$) faster than larvae fed any other diet (Table 1). The remaining diets tested did not differ in growth although all diets significantly outperformed the unfed controls. \

In Experiment 3 with 10 day old larvae, the diet containing *C. muelleri* again produced the greatest growth, although not significantly greater than a ternary diet containing *Tetraselmis chui* (Table 1). The ternary diet including *C. calcitrans* produced intermediate growth, less than the other ternary diets, but greater than the mono-specific diets. Of the mono-specific diets, *T. chui* produced significantly greater growth than either *C. mulleri* or *C. calcitrans*, which in turn did not produce significantly greater growth than observed in unfed controls.

Survival in each of the larval dietary trials was variable, but always exceeded 90% on average and did not differ significantly between treatments in any of the experiments.

4.3.3.2. Spat dietary preferences

Spat growth differed significantly as a function of diet ($F = 45.5$; $df\ 5/12$; $P < 0.0001$). Spat fed a ternary diet containing *C. muelleri* produced the greatest growth, although not significantly greater than a ternary diet containing *T. chui* or a diet of solely *C. muelleri* (Table 1). The two diets containing *C. calcitrans* (one ternary and one mono-specific) produced intermediate growth, less than the other ternary diets, but greater than the unfed controls.

Table 1. Growth of *S. glomerata* of various ages fed one of a range of diets for seven days.

Diet	1-day-old Larvae (Experiment 1)	5-day-old Larvae (Experiment 2)	10-day-old Larvae (Experiment 3)	3-day-old spat (Experiment 4)
<i>Chaetoceros calcitrans</i>	11.4 ± 1.7 ^a	52.3 ± 1.4 ^b	17.2 ± 3.2 ^a	1893 ± 76 ^b
<i>Chaetoceros muelleri</i>	10.3 ± 1.1 ^a	52.0 ± 3.2 ^b	19.6 ± 3.8 ^a	2034 ± 7 ^{bc}
<i>Tetraselmis chui</i>	10.0 ± 3.0 ^a	55.0 ± 2.0 ^b	42.6 ± 9.6 ^b	-
<i>Pav</i> , T Iso & <i>C. calcitrans</i>	34.2 ± 5.7 ^b	58.6 ± 8.7 ^b	69.2 ± 10.6 ^c	1958 ± 144 ^b
<i>Pav</i> , T Iso & <i>C. muelleri</i>	28.0 ± 0.3 ^b	69.9 ± 3.7 ^c	89.5 ± 9.9 ^d	2121 ± 35 ^c
<i>Pav</i> , T Iso & <i>T. chui</i>	33.3 ± 2.8 ^b	55.7 ± 1.7 ^b	83.1 ± 4.2 ^{cd}	2171 ± 105 ^c
Unfed	13 ± 5 ^a		27.8 ± 3.9 ^a	9.2 ± 2.3 ^a
1297 ± 18 ^a				
20,000L**	39.7	67.4	127.83	

* Values are means ± SD. Means within columns with a common superscript do not differ significantly ($P > 0.05$). Initial lengths; 1-day-old larvae 65.3 ± 1.8 µm; 5-day-old larvae 92.4 ± 3.8 µm, 10-day-old larvae 127.8 ± 14.51 µm, 9-day-old spat 1167 ± 67 µm.

** Values indicate mean growth increment for the source population of larvae held in the 20,000 L tank.

4.3.4. Discussion

Over 20 years of practical experience in the culture of mollusc larvae at Port Stephens Fisheries Centre (PSFC) has led to reliance upon three algal species as the primary diet: *P. lutheri*, *T. Isochrysis* and *C. calcitrans* (Nell and O'Connor, 1991; Heasman *et al.*, 1995). Further we have been aware that changes to the diet following metamorphosis have been beneficial in increasing spat growth rates and that the inclusion of species such as *C. muelleri* in particular improved spat performance (O'Connor *et al.* 1992). However, there had been a general assumption that this change in preference was a function of changing nutritional requirements post metamorphosis.

This study has supported the use of species such as *C. calcitrans* as early larval diets and corroborated the addition of *C. muelleri* to spat diets, but has clearly demonstrated that the optimal time for the inclusion of *C. muelleri* into the oyster diet is much earlier than previously expected.

In previous attempts to explain ontogenetic differences in food preferences, O'Connor *et al.* (1992) had noted that Ukeles (1975) had suggested that diatoms are not usually fed to larvae as most are too large and difficult to digest. The exception had been *C. calcitrans*, a small diatom that was common in larval diets. Of those diatoms that were small enough to be consumed by *S. glomerata* larvae (>10 µm in size, Wisely and Reid, 1978), such as *T. pseudonana*, ingestion could occur however the silica frustule surrounding these diatoms may inhibit digestion. In the light of this study, these explanations seem less likely and perhaps greater emphasis needs to be placed on either the changing dietary needs of larvae or the inherent difficulty in determining dietary preferences.

Commonly, studies of dietary preference have used an “iterative” approach to determining optimal diets. In previous studies at the PSFC, larvae have been fed a monospecific diet of one of 12 algal species. The best performed of these diets is then fed in combination with each of the remaining species to form a binary diet. The best binary diet is then supplemented each remaining individual species to form a ternary diet. In this way a total of 33 diets were assessed. There are however 1728 possible combinations of the 12 species in a ternary diet and therefore the chances of this approach selecting the optimal diet appear limited. In this instance at least, this diet was tested previously with *S. glomerata* larvae (O'Connor *et al.*, 1992) and again in this study and it is clear that there is an ontogenetic change in dietary needs, however it should be acknowledged that there could well be a number of other algal dietary combinations that may be preferential to those in current use.

4.3.5. References

- Alber, M. & Valiela, I., 1996. Utilization of microbial organic aggregates by bay scallops, *Argopecten irradians* (Lamarck). *J. Exp. Mar. Biol. Ecol.* 195, 71–89.
- Coutteau, P. & Sorgeloos, P., 1992. The use of algal substitutes and the requirement for live algae in the hatchery and nursery rearing of bivalve molluscs: an international survey. *J. Shellfish Res.* 11(2): 467–476.
- Enright, C.T., Newkirk, G.F., Craigie, J.S. & Castell, J.D., 1986. Evaluation of phytoplankton as diets for juvenile *Ostrea edulis* L. *J. Exp. Mar. Biol. Ecol.*, 96: 1–13.
- Epifanio, C.E., 1979. Comparison of yeast and algal diets for bivalve molluscs. *Aquaculture*, 16: 187–192.
- Harrison, P.J., Thompson, P.A. & Calderwood, G.S., 1990. Effects of nutrient and light limitation on the biochemical composition of phytoplankton. *J. Applied Phycology*, 2: 45–56.
- Heasman, M.P., O'Connor, W.A., O'Connor, S.J. & Languet, Y., 2002. Alternative means of nursery culture for the commercial scallop (*Pecten fumatus* Reeve) spat. *Aquaculture*, 213: 323–338.

- Holliday, J.E., 1985, International developments in oyster hatchery technology. Miscellaneous Bulletin, No. 1. Department of Agriculture, Brackish Water Fish Culture Research Station, Salamander Bay, NSW, 101 p.
- Jaeckle, W.B. & Manahan, D.T., 1992. Experimental manipulations of the organic composition of seawater: implications for studies of energy budgets in marine invertebrate larvae. *J. Exp. Mar. Biol. Ecol.*, 156: 273–284.
- Laing, I. & Millican, P.F., 1986. Relative growth and growth efficiency of *Ostrea edulis* L. spat fed various algal diets. *Aquaculture*, 54: 245–262.
- Langdon, C.J. & Waldock, M.J., 1981. The effect of algal and artificial diets on the growth and fatty acid composition of *Crassostrea gigas* spat. *J. Mar. Biol. Assoc. U.K.*, 61: 431–448.
- Manahan, D.T., 1990. Adaptations by invertebrate larvae for nutrient acquisition from seawater. *Am. Zool.*, 30: 147–160.
- Nell, J.A., 1993. The development of oyster diets. *Aust. J. Agric. Res.*, 44: 557–66.
- Nell, J.A. & O'Connor, W.A., 1991. The evaluation of fresh algae and stored algal concentrates as a food source for Sydney rock oyster *Saccostrea commercialis* (Iredale & Roughley) larvae. *Aquaculture*, 99: 277–284.
- O'Connor, W.A., Nell, J.A. & Diemar, J., 1992. The evaluation of 12 algal diets as a food source for Sydney rock oyster *Saccostrea commercialis* (Iredale & Roughley) spat. *Aquaculture*, 108: 277–283.
- Sokal, R.R. & Rohlf, F.J., 1981. Biometry. W. H. Freeman and Company, New York, NY, 895 pp.
- Thompson, P.J., Guo, M. & Harrison, P.J., 1993. The influence of irradiance on the biochemical composition of three phytoplankton species and their nutritional value for larvae of the Pacific oyster (*Crassostrea gigas*). *Mar. Biol.* 117, 259–268.
- Ukeles, R., 1975. Views on bivalve nutrition. In: Price, K.S. Jr., Shaw, W.N., Danberg, K.S. (Eds.), Proc. First. Int. Conf. Aquaculture Nutr. Univ. of Delaware, Newark, DE, pp. 127–162.
- Utting, S.D., 1985. Influence of nitrogen availability on the biochemical composition of three unicellular marine algae of commercial importance, *Aquacult. Eng.*, 4: 175–190.
- Walne, P.R., 1970. Studies on the food value of nineteen genera of algae to juvenile bivalves of the genera *Ostrea*, *Crassostrea*, *Mercenaria* and *Mytilus*. *Fishery Invest. Lond.*, Ser. II. 26(5), 62 pp.
- Webb, K.L. & Chu, F.L.E., 1983. Phytoplankton as a food source for bivalve larvae. In: G. D. Pruder, C. Langdon & D. Conklin (Editors), Proceedings of the Second International Conference on Aquaculture Nutrition: Biochemical and Physiological Approaches to Shellfish Nutrition. *World Maricult. Soc. Spec. Publ.*, 2: 272–291.
- Winer, B.J., 1971. Statistical Principles in Experimental Design. McGraw-Hill Kogakusha, Tokyo, pp. 205–210.
- Wisely, B. & Reid, B.L., 1978. Experimental feeding of Sydney rock oysters (*Saccostrea commercialis* = *Saccostrea culcullata*) I. Optimum particle sizes and concentrations. *Aquaculture*, 15: 319–331.

4.4. Suitability of a commercially available algal substitute for culture of Sydney rock oyster *Saccostrea glomerata* spat

4.4.1. Introduction

Appropriately chosen microalgal diets offer adequate nutritional value for larval and juvenile oysters; however, their production can constitute a major ongoing cost for hatcheries. Substitutes for live algal diets can lower operating costs through a more efficient use of resources (Jones *et al.*, 1974; O'Connor and Nell, 1991; Knuckey, 1998), as well as being more convenient than live batch algal culture.

The recent acceptance of hatchery produced *Saccostrea glomerata* spat by industry has led to an increased emphasis on hatchery efficiency and operational costs. Therefore we have endeavoured to reduce algal culture costs and in so doing reduce overall hatchery operational costs. These cost savings however can not compromise the quantity or quality of the spat being produced.

A number of artificial dietary substitutes and supplements have also been trialed on *S. glomerata* with varied success (Nell and Wisely, 1983; Nell *et al.*, 1996; Numaguchi and Nell, 1991; Southgate *et al.*, 1992). More than 20 years ago, adult *S. glomerata* were successfully “fattened” on non-encapsulated artificial diets (Nell and Wisely, 1983, 1984; Nell, 1985), but these diets were found to be unsuitable for larvae due to high bacterial numbers. In the early 1990s, Numaguchi and Nell (1991) demonstrated that gelatin-acacia microcapsules were a useful as a dietary supplement for *S. glomerata* larvae and Southgate *et al.* (1992) found microencapsulated diets with dissolved nutrient supported 80% of the larval growth measured in algae-fed larvae (Southgate *et al.*, 1992).

Recently a new compound bivalve feed developed by Nosan Corporation (Japan) has been released commercially and has undergone trials in commercial hatchery facilities within Australia. Known as M-1, this fine powdered diet has a particle size of 10 – 15 μm 's and a refrigerated shelf life of one year. Nosan's own proprietary testing has returned promising results with juvenile clams, scallops and pearl oysters which have reportedly shown increased growth and dry weight condition indices.

The aim of this experiment is to evaluate M-1 as a food source for juvenile *S. glomerata* spat.

4.4.2. Materials and methods

4.4.2.1. Algal cultures and substitutes

Axenic algal cultures were produced as described in the previous chapter and algal cell dry weights were taken from Nell and O'Connor (1991) and O'Connor *et al.* (1992). Algal concentrates used in this study were either created using a Sharples super centrifuge from these cultures or were purchased from Reed Mariculture Inc, USA. All concentrates were held in refrigerated storage and all diets involving concentrates were diluted in filtered seawater daily immediately before use. Care was taken to ensure concentrates resuspended thoroughly without clumping and the cell density of each concentrate suspension was determined before feeding.

The algal substitute “M1” (Nosan Corp, Japan) was held in refrigerated storage until required and then resuspended as required according to the manufacturers instructions. Feed rates were calculated based on 1 gm of M1 being the equivalent of 30 billion algal cells (M1 instructions, Nosan Corp, Japan).

4.4.2.2. General methods

Juvenile *S. glomerata* were produced in the Port Stephens Fisheries Centre Oyster hatchery using techniques described in the hatchery manual prepared in association with this report. The initial average length of the spat at the commencement of the experiment was $949 \pm 39 \mu\text{m}$'s ($n = 200$). Spat were held in the upweller systems described in the previous chapter (Fig 4.x.x). Four replicate upweller systems were used for each treatment. Each upweller housed 50 spat and the spat were placed in the upwellers for 24 h without food before the experiment commenced. The water temperature in each system was maintained at $25 \pm 0.5^\circ\text{C}$, by placing each system in a common heated water bath.

The buckets and upweller screens were cleaned and spat rinsed every second day using freshwater and the buckets refilled with 8 L of $1 \mu\text{m}$ temperature equilibrated filtered seawater. The experiment ran for 10 days, equivalent to the approximate time required for settled spat to be held in the hatchery before they are moved to field based nurseries and onto a natural diet. At the completion of each experiment all oysters from each treatment were removed from the upwelling systems and placed in 70ml containers where they were fixed in a 10% formalin solution. The shell length (APM) of 30 oysters in each treatment was measured using an eyepiece graticule at 40x magnification and mortalities were recorded.

4.4.2.3. 'M1' diets

M1 was combined with *C. muelleri* to form diets in which the relative percentages of M1 varied from 10 to 100% of the diet on a dry weight basis. All treatments were fed the equivalent of 100,000 cells/ml/day of Tahitian *Isochrysis* aff. *galbana*. To permit comparison with current hatchery practice, a treatment fed 50% *C. muelleri*, 25% *I. Isochrysis* and 25% *Pavlova lutheri* was used as a control diet for this experiment.

4.4.2.4. Statistical analysis

Homogeneity of variance was confirmed using the Cochran test (Winer, 1971) and the data from each experiment was analysed using a single-factor analysis of variance (ANOVA) and mean values were compared using Tukey's honestly significant different method (Sokal and Rohlf, 1981).

4.4.3. Results

The growth and survival of *S. glomerata* spat fed diets including various concentrations of M1 are shown in Table 1. The best performing diet was that made up of 50% M1 and 50% *C. muelleri*, which produced significantly greater growth than spat fed the standard hatchery diet (PIM). This 50% M1 diet did not however produce significant greater growth than diets incorporating up to 80 % M1. Spat fed diets containing more than 90% of either M1 or *C. muelleri* had significantly less growth than those spat fed the better performing diets. In general spat survival was high in all treatments with the exception of those fed solely M1.

Table 1. 'M1' in combination with fresh *Chaetoceros muelleri* as a food source for *Saccostrea glomerata* spat.

Diet	Total Growth ± SD (µm's)	Average Growth/Day ± SD (µm's)	Mortality (%)
M-1 10%	983 ± 38 ^c	98 ± 4	0.0 ^b
M-1 20%	985 ± 1 ^c	99 ± 1	0.0 ^b
M-1 30%	1080 ± 27 ^{bc}	108 ± 3	0.0 ^b
M-1 40%	1094 ± 22 ^{bc}	109 ± 2	2.5 ^b
M-1 50%	1278 ± 21 ^a	128 ± 2	0.0 ^b
M-1 60%	1154 ± 61 ^b	115 ± 6	0.0 ^b
M-1 70%	1138 ± 65 ^b	114 ± 7	0.0 ^b
M-1 80%	1183 ± 52 ^{ab}	119 ± 5	0.0 ^b
M-1 90%	993 ± 33 ^c	99 ± 3	4.1 ^b
M-1 100%	699 ± 31 ^d	70 ± 3	19.1 ^a
PIM	1130 ± 32 ^b	113 ± 3	0.0 ^b

Values are means ± SD. For the total growth and mortality columns means with a common subscript do not differ significantly ($P > 0.05$).

4.4.4. Discussion

The powdered M1 was found to be an extremely useful partial substitute for algae in the diets of *S. glomerata* spat. When fed in conjunction with fresh *C. muelleri*, at substitution rates of between 50% to 80%, M1 produced growth and survival equivalent or better than the standard hatchery diet of *C. muelleri*, *T. Isochrysis* and *P. lutheri*. This new diet therefore holds considerable promise for use with *S. glomerata*.

Although the time spat are maintained within the hatchery before transfer to the field is comparatively brief (2 weeks), it does however cause some production inconvenience at the PSFC and the opportunity to use up to 80% M1 can offer significant advantages. Recent estimates of algal demand have shown that on a volume basis, over 80% of the food produced at the PSFC is fed to broodstock, while of the remainder, 40% goes to larvae and 60% to spat. Larvae are fed algae grown in 10 L carboys, while spat demand increases to the extent that we are required to move to 500 L bag cultures. With the inclusion of M1, it is now possible to continue to feed from carboys without requiring the bag system to be used. This in turn means that for certain production runs for which reproductively mature oysters can be obtained directly from the field, it is possible to run commercial scale batches of *S. glomerata* (10 million spat) without the use of the bag culture system. This reduces the start-up time required to prepare algae before production can commence as well as significantly reducing labour and algal production costs. The advantages for other

hatcheries will vary according to their algal production systems and requirements, however M1 is still likely to offer significant advantages.

Perhaps of greater interest is the potential for M1 to be incorporated in to broodstock diets. Currently, the same diet used for juveniles is also used for the maintenance and conditioning of broodstock *S. glomerata*, albeit in far greater quantities. The success of M1 in spat diets has encouraged its use with broodstock and preliminary evaluations in this regard have been promising.

From a practical perspective, M1 has been well received by hatchery staff. Storage is simple and the suggested shelf life of 12 months is more than sufficient. The preparation of the diet is not particularly onerous and does not require specialist equipment. M1 does however have a tendency to settle out of suspension which could reduce availability and cause water quality problems if not addressed. To reduce the likelihood of such problems we have drip fed the diet into tanks to encourage its immediate consumption and have tried to ensure adequate aeration in the tanks to prolong suspension.

4.4.5. **References**

- Jones, D.A., Mumford, J.D. & Gabbott, P.G., 1974. Microcapsules as artificial food particles for aquatic filter feeders. *Nature*, 247: 233–235.
- Knuckey, R.M., 1998. Isolation of Australian microalgae and preparation of microalgal concentrates for use as aquaculture feeds. University of Tasmania, December 1998.
- Nell, J.A., 1985. Microparticulate diets for aquaculture evaluated. *Feedstuffs*, 57(22): 16–17.
- Nell, J.A. & Wisely, B., 1983. Experimental feeding of Sydney rock oysters (*Saccostrea commercialis*). II. Protein supplementation of artificial diets for adult oysters. *Aquaculture*, 32: 1–9.
- Nell, J.A., Diemar, J.A. & Heasman, M.P., 1996. Food value of live yeasts and dry yeast-based diets fed to Sydney rock oyster *Saccostrea commercialis* spat. *Aquaculture*, 145: 235–243.
- Nell, J.A. Wisely, B., 1984. Experimental feeding of Sydney rock oysters (*Saccostrea commercialis*). III. Food concentration and a comparison of oyster fattening procedures. *Aquaculture*, 37: 197–208.
- Numaguchi, K. & Nell, J.A., 1991. Effects of gelatin-acacia micro capsule and algal meal supplementation of algal diets on growth rates of Sydney rock oyster, *Saccostrea commercialis* (Iredale & Roughley), larvae. *Aquaculture*, 94: 65–78.
- O'Connor, W.A. & Nell, J.A., 1991. The potential of algal concentrates as food for the production of Australian bivalves. In G.L. Allan and W. Dall (Editors), Proc. Aquaculture Nutrition Workshop, 15 – 17 April 1991, NSW Fisheries, Brackish Water Fish Culture Research Station, Salamander Bay, Australia, 248 pp.
- Southgate, P.C., Lee, P.S. & Nell, J.A., 1992. Preliminary assessment of a microencapsulated diet for larval culture of the Sydney rock oyster, *Saccostrea commercialis* (Iredale & Roughley). *Aquaculture*, 105: 345–352.

4.5. Evaluation of spat bottles for rearing Sydney rock oyster *Saccostrea glomerata* spat

4.5.1. Introduction

This chapter evaluates the effectiveness of a spat bottle system compared to downweller set systems for rearing *S. glomerata* spat. A spat bottle system suspends spat in a continual flow of seawater dosed with algae and are used to enhance spat rearing in the period that spat reside in a bivalve hatchery. The growth rates of spat reared in spat bottles and downweller set systems were compared for three batches. This work addresses Objective 3 of this study which was to ‘trial economical, low cost alternative techniques for spat rearing to enhance production’.

An alternative spat rearing method to conventional downweller set systems (Bayes 1981, Frankish *et al.* 1991) is a spat bottle system. This system is comprised of a series of inverted bottles connected to a reservoir tank (Figure 1). The constant water flow creates a fluidised bed that keeps the spat continually circulating. More information about spat bottle systems is contained in Section 8.2 of the Hatchery Manual. The spat bottle system at PSFC hatchery had 5 bottles mounted in series (Figure 1). Approximately 500,000 spat can be stocked into each bottle and seawater dosed with food is delivered at the base of the bottle.

Spat are transferred into the spat bottle system from downweller set systems when screens contain a low proportion (<5%) of pediveliger larvae and when spat are approximately 500 µm in size, that is, when they are retained on a 350 µm screen. If pediveliger larvae are inadvertently stocked into spat bottles they are generally ejected from top of bottles in the effluent water and can be recaptured on a 180 µm back-up screen.

Spat rearing at PSFC hatchery in the past has primarily occurred in downweller set systems. These systems are comprised of up to ten PVC screens, approximately 450 mm in diameter, with 180 µm mesh. Screens are placed in a rectangular, 1,300 L tank and overhead spray bars connected to a submersible pump provide a downward flow of seawater through each screen (See Figure 8.1 in the Hatchery Manual). The tank is aerated and heaters are used to maintain water temperature at about 25°C. Each PVC screen is stocked with approximately 250,000 shell set or 500,000 epinephrine set pediveliger larvae. Stocking density of tanks starts at about 1.4 larvae ml⁻¹ when initially stocked and is usually decreased to approximately 0.7 larvae ml⁻¹ as more pediveliger larvae metamorphose into spat (Frankish *et al.* 1991). Tanks are dosed with algal mixtures twice daily starting at approximately 50,000 cells larvae⁻¹ day⁻¹ which is increased to 140,000 cells spat⁻¹ day⁻¹ when screens contain predominately spat. Epinephrine set spat are able to be separated from pediveliger larvae by gentle wet sieving using a 265 µm screen, whereas a 350 µm screen is used to separate shell set spat from pediveliger larvae.

Three trials were conducted for this study that measured growth rates of spat stocked in a downweller set system and a spat bottle system to evaluate the effectiveness of spat bottles for rearing *S. glomerata* spat. The duration of trials ranged from eight to twelve days.

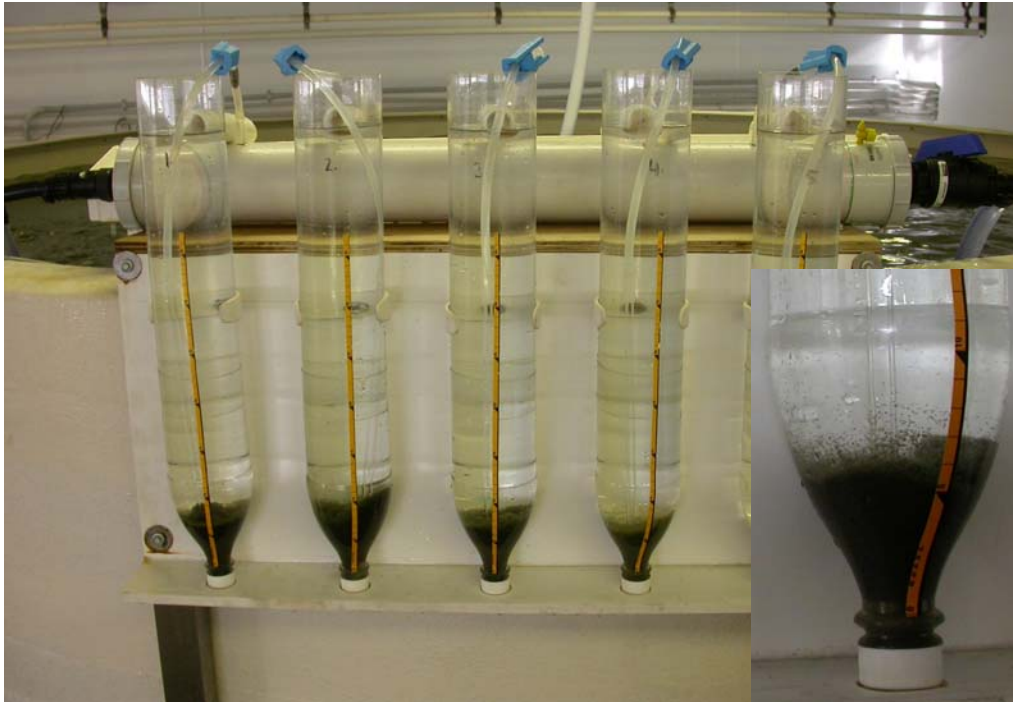

Figure 1. PSFC bivalve hatchery spat bottle system containing *S. glomerata* spat. Inset shows close-up of spat in the base of the bottle.

4.5.2. *Material and methods*

The spat bottle system and downweller set system used for this experiment are described in detail in Section 8.2 (SRO Hatchery Manual) of this document. Four screens and two bottles were used in the first trial and each screen and bottle was stocked with approximately 300,000 and 600,000 *S. glomerata* spat, respectively. Two screens and two bottles stocked at the same densities were used for Trial 2 and 3. The average starting size and final size of spat for each trial are listed in Table 1. Random sub-samples of spat were removed from experimental screens and bottles throughout each trial to determine the size of spat. Light microscopy (40X magnification) was used to measure the shell width of approximately 50 spat from each screen or bottle used for the study. Instantaneous growth, expressed as percent increase in shell width per day, was calculated for each trial using the formula:

$$\% \text{ increase per day} = (\ln[W_t/W_0]/t) \times 100$$

Where W_0 is the initial mean shell width in μm and W_t is the mean shell width at time “t” in days. Instantaneous growth rate was calculated from pooled data from all screens and bottles for each trial. Single factor analysis of variance (ANOVA) using Statgraphics Plus V4.1 software was used to compare instantaneous growth.

4.5.3. Results

Figure 2 shows the performance of spat reared in the two systems for each trial. Spat stocked in the bottle system were larger than spat from the downweller set screens at the conclusion of each trial despite spat being smaller at the start of the experiment in Trials 2 and 3 (Figure 2). The average growth rate of spat reared in the bottle system was 7.4 % increase in shell width per day (Table 1). This figure was significantly ($F = 15.90$; $df 1/4$; $P < 0.05$) greater than the average growth rate for spat reared in downweller set system screens which was calculated to be 5% increase in shell width per day (Table 1).

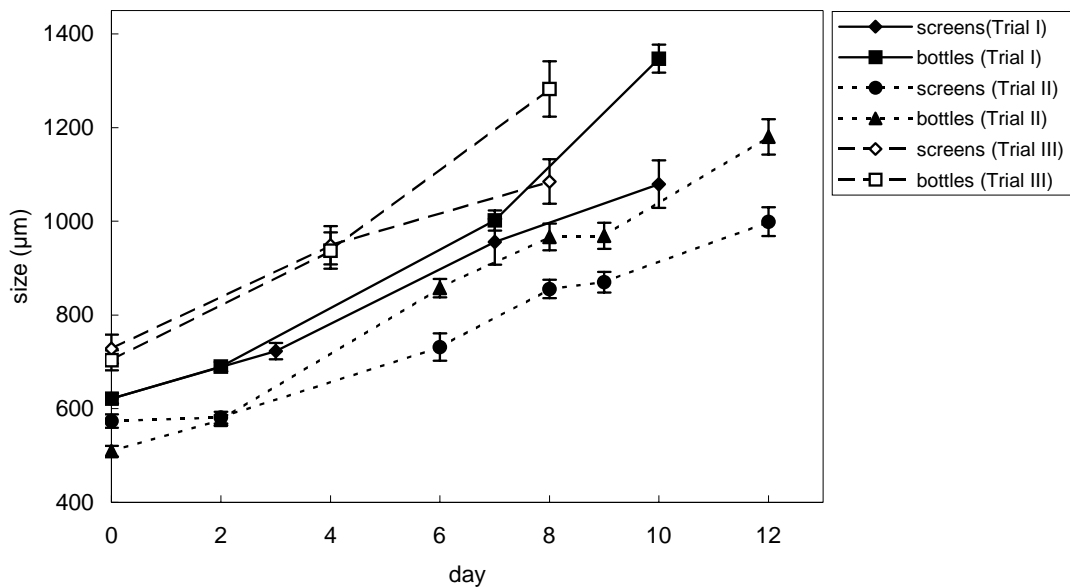

Figure 2. Mean spat size in bottles and screens during Trial 1, 2 and 3. Error bars show the 95% confidence interval.

Table 1. Description of Trials 1, 2 and 3 and spat growth rate expressed as % increase per day.

Trial	Duration (days)	SCREENS			BOTTLES		
		Ave. Initial Size (µm)	Ave. Final Size (µm)	Growth Rate*	Ave. Initial Size (µm)	Ave. Final Size (µm)	Growth Rate*
1	10	622	1080	5.5	622	1347	7.7
2	12	574	999	4.6	509	1181	7.0
3	8	728	1085	5.0	703	1283	7.5
Ave.				5.0			7.4

* percentage increase in shell width per day

4.5.4. Discussion

Spat grew significantly faster in the spat bottle system compared to downweller screens. No significant spat mortalities were observed in either type of system during the three trials. The bottle system worked effectively for Sydney rock oyster spat rearing, decreasing the time needed to hold spat in the hatchery and increasing the overall production level of the hatchery.

Flow rate of water delivered to each bottle is critical for: keeping spat suspended; food supply; and, to remove waste products. Food density of the water delivered to the spat bottle system at PSFC is maintained between 100,000 to 150,000 cells ml⁻¹ and flow rate is adjusted regularly (every 6 h) by visual observation to allow for the increase in mass of spat over time. Flow rate is dependent on the number and size of spat stocked into a bottle system. For example, a single bottle in the system at PSFC stocked with 500,000, 350 µm retained spat requires approximately 1 L min⁻¹. If the same number of spat were retained on a 670 µm screen a flow rate greater than 3 L min⁻¹ would be required. These figures are only a guide for the PSFC system and velocity of flow into a bottle should be adjusted so that spat: do not stagnate for periods of time; and, are not forced high into the water column of the bottle. Washing of spat in fresh water and cleaning bottles was done daily to maintain hygiene levels.

Spat bottle systems need to be used in conjunction with downweller set systems but offer a low cost, economical alternative method for rearing spat in the period spat are held in a hatchery post settlement. Bottle systems increase the overall production capability of a hatchery because of their compact design, requiring minimal floor space, and capacity.

4.5.5. References

- Bayes, J.C. 1981. Forced upwelling systems for oysters and clams using impounded water systems. Proceedings from an International Workshop on Nursery Culturing of Bivalve Molluscs. Special Publication of the European Mariculture Society, **7**, 73–83.
- Frankish, K.R., L.J. Goard & W.A. O'Connor. 1991. The development of hatchery rearing techniques of the Sydney rock oyster (*Saccostrea commercialis*) at the Brackish Water Fish Culture Research Station, Salamander Bay, NSW, 2301. 26 pp.

4.6. The tolerance of Sydney rock oyster, *Saccostrea glomerata* spat to air exposure and the implications for transportation

4.6.1. Introduction

The Sydney rock oyster is typically found in the intertidal and subtidal zone, predominately in estuaries, and is distributed between the NSW and Victorian border in the south and Townsville in the north (Nell 1993). Over this geographic range there are wide variations in water and air temperatures, which are dependent on season and climate.

SROs are a very tolerant bivalve species with spat and adults able to withstand a wide temperature range both in and out of water. Optimum growing water temperatures for adult oysters are between 18°C and 26°C (Holliday 1995). Maximum filtration rates occur at temperatures between 25°C and 30°C (Souness & Fleet 1979) and optimal temperatures for growth of SROs vary depending on their stage of development. Optimal water temperature for newly settled spat growth was found to be higher than for adults and was in the range of 24 to 30°C.

Rack-tray or long line intertidal systems and subtidal raft culture are the two main methods used to cultivate SROs. Intertidal SROs are exposed to the atmosphere for short durations over the tidal cycle causing more extreme and abrupt temperature variations due to the possibility of air temperatures exceeding 40°C in northern estuaries in summer and falling below 0°C in southern estuaries in winter. Oysters farmed using subtidal raft culture are also air exposed when they are removed from the water for short periods to kill and control overcatch as well as other epiphytic growth on the shell. Other times when SROs are air exposed for extended periods is during transport from either: an oyster hatchery to a nursery as juveniles; movements during growout; or, to markets. Juvenile SROs are likely to be the most vulnerable to air exposure because of their small size, fragile shell, weak adductor muscle as well as their naivety to this environment. Emersion is generally unavoidable at this stage due to stock requiring distribution from hatcheries to estuaries for on-growing. Presently, there is no information available on the tolerance of juvenile or adult SROs to air exposure.

SRO spat typically close valves when water quality conditions, in particular salinity, fluctuate markedly, as well as when they are removed from water. Shell closure protects the soft tissues by practically isolating them from conditions external to the shell. When salinities drop below 15 ppt adult SROs can survive for periods of more than 14 days by simply closing their valves (Holliday 1995). Prolonged shell closure in oysters invariably results in mortality.

Transportation of SRO spat in the past has been putatively linked to spat mortalities. This study was conducted to investigate stress to spat induced by air exposure. A series of experiments were performed that exposed different sized spat to air. Spat used were representative of the size transported from hatcheries and field nurseries. Ways to minimise emersion stress were investigated in addition to different temperatures commonly experienced during transport to determine an optimal temperature and method to minimise spat losses.

4.6.2. *Materials and methods*

All SRO spat used in this study were produced and reared at the PSFC hatchery using the methods and techniques outlined in the Sydney Rock Oyster Hatchery Manual. Before the start of the experiments listed below, spat were held in downweller systems containing filtered seawater (1 μm nominal) at 25°C and 34 ppt and fed to excess mixtures of Tahitian *Isochrysis* aff. *galbana*, *Pavlova lutheri*, *Chaetoceros muelleri* and *Tetraselmis chui*. Stress to spat from air exposure was assessed by determining the proportion surviving spat after air exposure and a 24 h recovery period. Recovery involved transferring spat to 120 ml vials containing filtered seawater (1 μm , 25°C and 34 ppt) and approximately 150,000 cells ml^{-1} of the abovementioned algal species. Spat were categorised as dead if they had gaping shells that contained no soft tissue or did not close with a tactile stimulus.

4.6.2.1. *Experiment 1: The effect of duration of air exposure at 25°C on spat survival*

Three size classes of spat with average shell heights (\pm SD) of 931 \pm 120 μm , 1682 \pm 247 μm and 2278 \pm 536 μm were removed from a downweller system and divided into 15 groups of 30 and placed onto paper towelling. Spat were then transferred to an air-conditioned temperature controlled room at 25°C. Fans generated a constant airflow in the room and three 200 L tubs were filled with water to maintain a constant humidity level. At 6, 12, 24, 36 and 48 hours, three randomly selected groups of small spat were transferred to 120 ml vials for recovery. Three randomly selected groups of medium sized spat were transferred to 120 ml vials containing filtered seawater at 14, 24, 48 and 72 h and three randomly selected groups of large sized spat were transferred at 30, 52, 72 and 120 h. A stereo dissecting microscope (magnification = x 25) was used to count the number of dead spat in each vial immediately after the recovery period.

4.6.2.2. *Experiment 2: The effect of duration of air exposure and temperature on spat survival*

Small spat (1334 \pm 151 μm , average shell height \pm SD) and large spat (2278 \pm 536 μm , average shell height \pm SD) were removed from a downweller system and were divided into 30 groups of 30 large and small spat. Groups were placed in an internal chamber of an airtight 120 ml vial (Figure 1). The void outside the internal chamber was partially filled with water to create a water bath to maintain a constant temperature and humidity level during the experiment. The 120 ml vials were inserted into individual compartments of a temperature controlled insulated aluminium block.

After temperatures had stabilised within the vials seated in the aluminium block, 6 groups of small spat were stocked into the inner chamber at 19, 22, 26, 30 and 33°C. Three vials from each temperature were removed at 14 hours and 24 hours and transferred to 120 ml vials for recovery. Large spat were stocked in exactly the same way and at the same temperatures, but, these spat remained in the experimental apparatus for longer and were removed at 48 and 77 hours. Three groups of 30 small spat and 30 large spat were maintained in 100 ml of filtered seawater during the experiment and monitored for survival when samples were removed from the aluminium block and at the end of the recovery period.

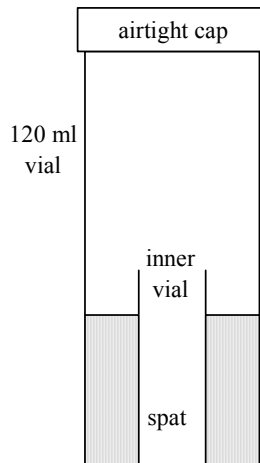

Figure 1. Capped 120 ml vials used for spat emersion for Experiment 2. Shading shows water surrounding the inner vial where spat are placed.

4.6.2.3. *Experiment 3: The effect of exposure and moisture at 25°C on spat survival*

This experiment investigated whether keeping spat protected and moist during transport increased spat survival. Four groups of 30 spat with an average shell size (\pm SD) of $1682 \pm 247 \mu\text{m}$ were either: fully exposed to air (exposed); wrapped in moist towel and sealed into plastic bags (protected); or, wrapped in moist towel and sealed in plastic bags containing oxygen (protected + oxygen). Air exposure was conducted in an air-conditioned temperature controlled room held at 25°C under the same conditions described for Experiment 1. An additional four groups of thirty spat were left immersed in filtered seawater (25°C and 34 ppt) for the entire experiment. Four groups of spat from each treatment were returned to 120 ml vials containing filtered seawater (25°C and 34 ppt) at 14, 24, 48 and 72 hours and left for 24 hours before number of dead spat were counted using the same methods detailed above.

4.6.3. **Results**

4.6.3.1. *No emersion treatments*

For all experiments additional spat were maintained in replicated aquaria that contained seawater to ensure spat used were of good health. The highest level of mortality recorded in these treatments was 13.2% and was recorded for spat 931 μm in size (Experiment 1). All other mortalities in spat held in filtered seawater during emersions were above 10% for all other experiments.

4.6.3.2. *Experiment 1: The effect of duration of air exposure at 25°C on spat survival*

The results from air exposure of different sized SRO spat are displayed in Figure 2. Larger sized spat have a greater tolerance to air exposure at 25°C however significant losses occurred still occurred in 2278 μm spat after 30 hours of exposure. Smaller spat representative of the size commonly translocated from the hatchery to field nurseries suffered significant mortalities after only 6 hours of air exposure at 25°C. All of the 931 μm spat had died within 48 hours of air exposure at this temperature whereas approximately 50% of the 2278 μm spat had died within this same period. Experiment 1 directly exposed spat to the atmosphere with no protection. The

following experiments investigated tolerance to air exposure in more enclosed and protective environments.

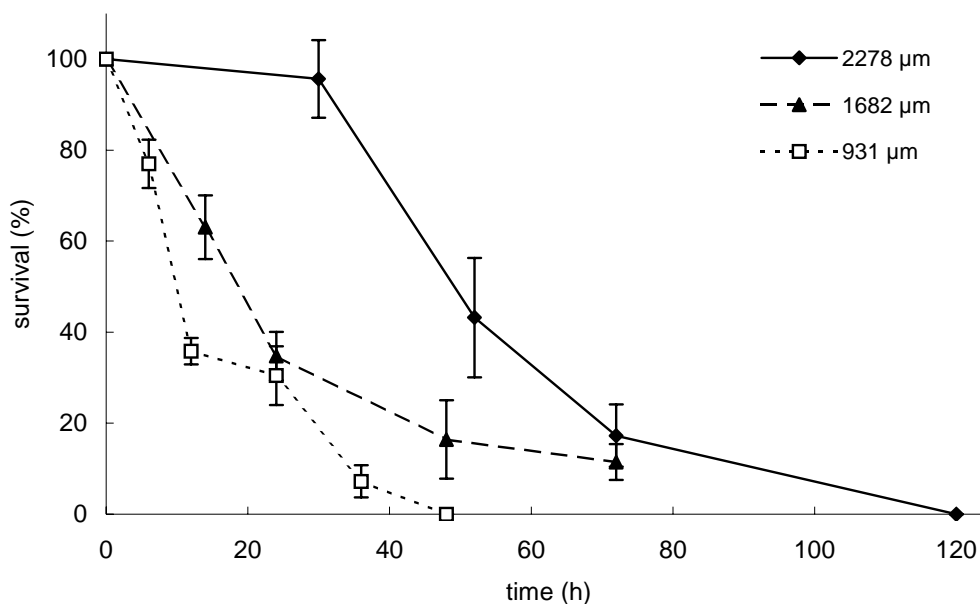

Figure 2. Survival of three different size grades of spat to air exposure at 25°C (error bars display the 95% confidence intervals).

4.6.3.3. Experiment 2: The effect of duration of air exposure and temperature on spat survival

Results of Experiment 2 are displayed in Figure 3. A two factor analysis of variance (ANOVA) was used to investigate differences between the two fixed factors time and temperature in Experiment 2. Table 1 summarises the results from the two factor ANOVA performed for the two size classes of spat (1334 µm and 2278 µm).

Both the duration of air exposure and the temperature spat were air exposed to significantly affected survival of spat in both size classes (Table 1). The ANOVA results also indicate that there was an interaction between time and temperature on spat survival (Table 1).

4.6.3.4. Experiment 3: The effect of exposure and moisture at 25°C on spat survival

The results of the two factor ANOVA for the comparison of time of removal and type of emersion are listed in Table 2. Figure 4 shows the survival of 1334 µm spat when either fully exposed to air, enclosed in a sealed and moist bag or enclosed in a sealed and moist oxygenated bag. Protection of spat by enclosing them while they are emersed significantly reduced the level of mortality (Figure 4 and Table 2). However, using oxygen in sealed bags did not increase spat survival compared to using air in sealed bags.

A.

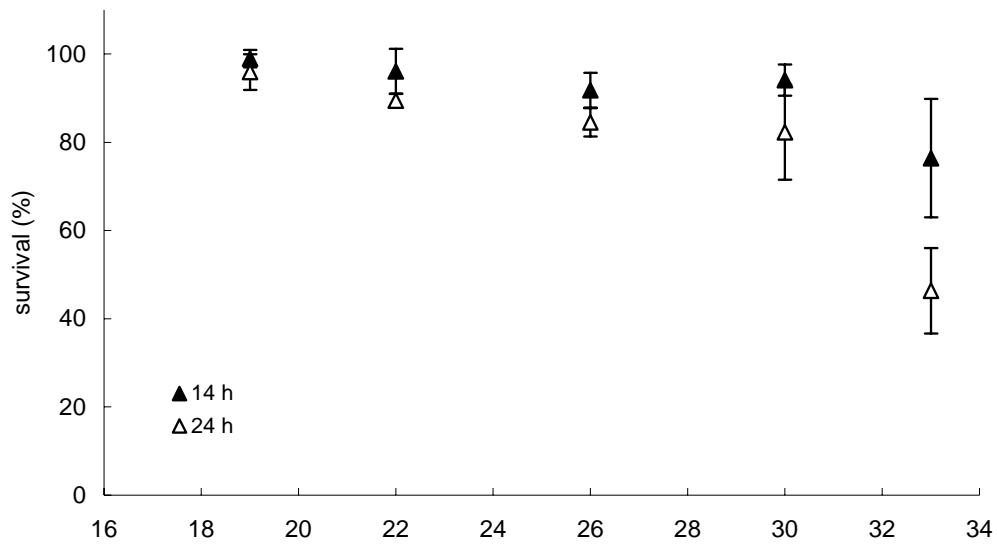

B.

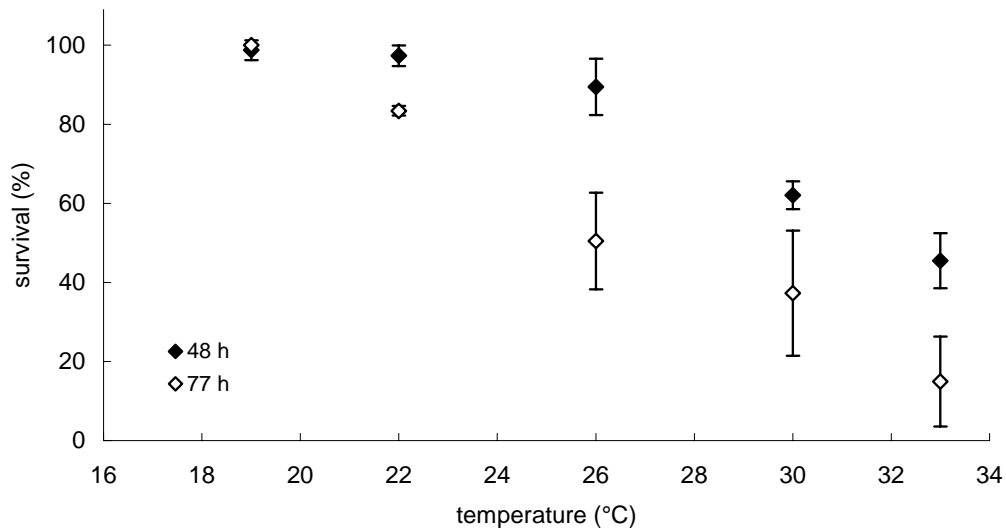

Figure 3. Survival of 1334 µm spat (A) and 2278 µm spat (B) at temperatures between 19 C and 33°C.

Table 1. Summary of the two factor ANOVA results for small (1334 μm) and large (2278 μm) spat from Experiment 2.

Source of variation	df	Mean Square	F	p
Spat (1334 μm)				
Time	1	1040.9715	27.93	0.0000
Temperature	4	1188.4450	31.89	0.0000
Time x Temperature	4	171.2218	4.59	0.0086
Error	20	37.2661		
Spat (2278 μm)				
Time	1	3432.8429	67.09	0.0000
Temperature	4	4876.2217	95.30	0.0000
Time x Temperature	4	365.1290	7.14	0.0010
Error	20	51.1668		

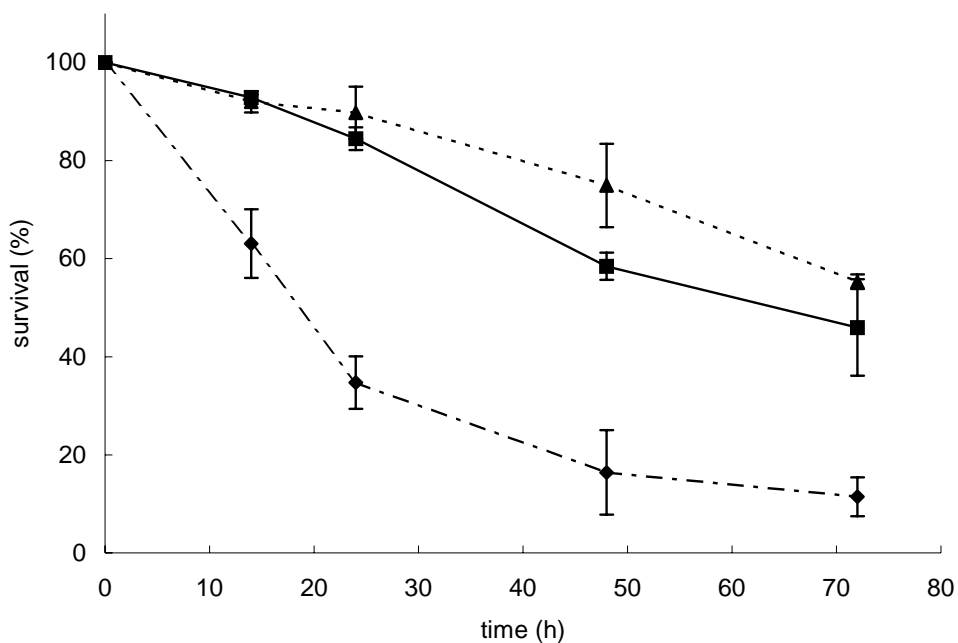

Figure 4. Survival of spat (average size 1334 μm) to emersion when fully exposed (diamonds), protected in sealed bags (triangles) and protected in oxygenated sealed bags (squares).

Table 2. Results of the two factor ANOVA for comparison of time of removal and type of emersion.

Source of variation	df	Mean Square	F	p
Time	3	4842.6364	144.81	0.0000
Exposure Type	2	9991.5823	298.79	0.0000
Time x Exposure Type	6	204.6036	6.12	0.0002
Error	36	33.4407		

4.6.4. Discussion

The size of spat and the duration of emersion are two critical factors to consider when handling juvenile SRO spat. There are ways to reduce stress caused by emersion to oyster spat. The most effective method involves isolating spat from the atmosphere by sealing them in moist airtight containers and ensuring that spat remain below 20°C while out of water. The enclosed airtight environment used for Experiments 2 and 3 increased the survival rate of spat considerably compared to those spat completely exposed to the atmosphere.

Hatchery production of SROs involves removal of spat from seawater for cleaning and grading for very short periods, usually less than 15 minutes. When spat reach a size large enough to be deployed to field-based nurseries they require transportation in an emersed state for periods of up to 12 h. This generally occurs when spat are retained on 500 µm mesh and shell height is usually >750 µm. Ideally, spat of this size should be translocated as efficiently as possible, in a protective container with temperature maintained below 20°C to minimise mortalities.

Presently, SRO oysters are produced at New Tech Aquaculture, Hervey Bay (Queensland) and at the Port Stephens Fisheries Centre (PSFC), located at Taylors Beach (New South Wales). In the past, transportation of spat has co-occurred with spat mortalities of around 30% in the days immediately following this activity. Field nurseries are located as far north as Moreton Island (southeast Queensland) and as far south as Pambula River, just north of the NSW and Victorian border. Depending upon where spat are produced, road transportation could potentially take more than 24 hours. Air transportation has been used successfully to reduce this time and works well when there are minimal delays between: placement on an aircraft; connecting flights; and, drop off and collection of the spat from the airport terminal at their destination. Another factor to consider is that transport of hatchery reared spat commonly occurs during spring, summer and autumn seasons where there is a reasonable likelihood of very hot daytime temperatures in NSW and Queensland.

After spat have reached the field nursery, apart from short air exposures for washes, the next extended air exposure occurs when they are transported to other estuaries for growout. This is generally when spat are retained on 3 or 4 mm mesh and have developed to a stage where they can withstand much longer and harsher transport periods (Figure 3). Once again, to avoid stress and reduce the risks of losses transport should be conducted in the same way as for hatchery spat. Nursery operators have effectively used mesh bags inside polystyrene foam boxes with wet paper towelling to create and maintain a moist and humid environment during transport.

Transportation of oysters has traditionally been for two primary reasons. Firstly, natural spatfall varies considerably throughout the SROs growing range. Therefore juvenile spat of various sizes are sold by growers in estuaries with high natural spatfall levels, for example the Hastings River, to estuaries that cannot achieve their stocking numbers from naturally caught seed. Estuaries in the southern half of the SROs range generally purchase spat from further north. Secondly, oyster growers may have leaseholds in multiple estuaries and move stock between estuaries to take advantage of improved growout or conditioning areas offered by alternative estuaries. This procedure has diminished considerably of late because of the influence of disease, notably QX, which has brought about tight restrictions on the movement of oysters between affected and non-affected areas.

When oyster growers expose oysters to the atmosphere for extended periods of time, either to remove overcatch and fouling or transport to market, they take into consideration: the prevailing climatic conditions; the size of the oysters; and, the conditions, particularly salinity in the estuary prior to removal to judge the duration of air exposure that oysters can tolerate. Presently, there is no published information available for SRO growers to determine air exposure durations and growers largely rely on acquired experience and knowledge.

Independent of oyster size, when valves remain closed for extended periods a number of changes occur internally and the rates of these changes are largely dependent on the external conditions, in particular ambient temperature (Burnett & Milardo 2000). When oyster shells close: tissues become hypoxic; haemolymph O₂ pressure decreases; and, CO₂ build up decreases haemolymph fluid pH (Morrison 1993; Burnett & Milardo 2000; Galtsoff 1964; Dwyer & Burnett 1996). The shell condition, strength and structure are critical to extending periods of air emersion. If very small spat do not have fully developed shells or adductor muscles to enable firm closure and an effective seal, the soft tissues will be exposed to the surrounding environment.

This study has shown that spat mortalities increase with duration of air exposure and that air exposure temperature also has a significant effect on spat mortalities. This study used spat of the same size that would be transported from hatcheries and field based nurseries. The results show that spat should be transported quickly and maintained at temperatures below 20°C. Transferring spat in mesh bags on moist paper towelling is recommended as it prevents spat from drying out while air exposed and reduces the chance of large temperature fluctuations. Additionally, foam boxes used for transport should be out of direct sunlight and wind to reduce heating and drying. The use of air-conditioned vehicles for transport is recommended as it enables some level of control over temperatures experienced during transport.

4.6.5. **References**

- Burnett, L.E. & C.S. Milardo. 2000. Inside the shell of an intertidal oyster: liabilities and benefits? *Journal of Shellfish Research*, 19:642.
- Dwyer, J.J. III & L.E. Burnett. 1996. Acid-base status of the oyster *Crassostrea virginica* in response to air exposure and to infections by *Perkinsus marinus*. *Biological Bulletin*, 190:139–147.
- O'Connor, W.A., M.C. Dove, B. Finn & S. O'Connor. 2008. Hatchery Manual for Sydney rock oysters, *Saccostrea glomerata*. NSW DPI Final Report Series 11. Nelson Bay. 53 pp.
- Galtsoff, P.S. 1964. The American oyster *Crassostrea virginica* Gmelin. *Fishery Bulletin of the Fish and Wildlife Service*, 64. 480 pp.
- Holliday, J.E. 1995. 'Nursery Culture of Sydney Rock Oysters, *Saccostrea commercialis* (Iredale and Roughley, 1933) and Pacific Oysters *Crassostrea gigas* (Thunberg, 1793).' Unpublished PHD Thesis, Department of Aquaculture, University of Tasmania.

- Morrison, C.M. 1993. Histology and cell ultrastructure of the mantle and mantle lobes of the Eastern oyster, *Crassostrea virginica* (Gmelin): a summary atlas. *American Malacological Bulletin*, 10:1–24.
- Nell, J.A. 1993. Farming the Sydney Rock Oyster (*Saccostrea commercialis*) in Australia. *Reviews in Fisheries Science*, 1:97–120.
- Souness, R.A. & G.H. Fleet. 1979. Depuration of the Sydney rock oyster, *Crassostrea commercialis*. *Food Technology Australia*, 31:397–404.

4.7. Commercial assessments of growth and mortality of fifth generation Sydney rock oysters *Saccostrea glomerata* selectively bred for faster growth

4.7.1. Introduction

The Sydney rock oyster industry is more than 120 years old and has always relied on variable natural spatfall. It can take more than three years to grow naturally caught *S. glomerata* to 'plate' grade (whole oyster weight ranges between 40 to 60 g), the premium grade for this species (Nell 1993). Pacific oysters, which can only be cultivated in Tasmania and South Australia as well as Port Stephens in NSW, Australia can grow at more than twice this rate. The cultivation time for Pacific oysters can be further reduced by growing hatchery-produced triploid *C. gigas*.

In 1990, a NSW Department of Primary Industries (DPI) oyster breeding program commenced with the objective of producing selectively bred *S. glomerata* oysters that were faster growing and had resistance to winter mortality disease to increase the profitability of this industry (Nell *et al.* 2000). The breeding program was expanded in 1997 to selectively breed oysters with resistance to QX disease (Nell *et al.* 2000). Presently, there are four parallel breeding lines (Line 1, 2, 3 and 4) selected for fast growth at Port Stephens, NSW (Nell & Perkins 2005) and three breeding lines selected for winter mortality disease, QX disease and both diseases at the Georges River, NSW (Nell & Perkins 2006).

Improvement of the breeding lines selected for fast growth since 1990 is documented in the following studies: Nell *et al.* (1996); Nell *et al.* (1999); Hand *et al.* (2004); and, Nell & Perkins (2005). Oysters from Line 2 have consistently outperformed oysters from the other three lines (Nell & Perkins 2005). Bayne *et al.* (1999) investigated why progeny of the third generation selected for faster growth increased in size and weight more rapidly than non-selected oysters. It was found that selected oysters were not only feeding at a faster rate over a wide range of food levels, but also converted food to growth more efficiently (Bayne *et al.* 1999). The average time taken for progeny of the fourth generation of all four breeding lines selected for fast growth to reach market size (50 g) at Port Stephens was 28.5 months, with selected oysters reaching this benchmark 12.5 months before the Control oysters (Nell & Perkins 2005).

Hatchery production of *S. glomerata* first started in the mid 1980s to provide an alternative source of spat instead of reliance on naturally-caught spat. However, hatchery runs were plagued by recurrent mass mortality syndromes occurring in both larvae and spat. Most *S. glomerata* runs failed within the first eight days of larval culture and runs that actually produced spat were commonly impacted by sudden spat mortality, which caused losses of 60 – 90% (Heasman *et al.* 2000).

Several million dollars were invested by state and federal funding agencies into the breeding program but ongoing hatchery failures in commercial runs meant that industry could not purchase selectively bred spat for their oyster farms. In July 2003, a research and development program was commenced by NSW DPI to overcome *S. glomerata* hatchery rearing diseases and develop reliable commercial-scale hatchery techniques for *S. glomerata*. Implementation of new rearing protocols and methods and better understanding of nutritional and culture requirements for *S. glomerata* brought about reliable commercial scale hatchery production demonstrated by 11 consecutive successful commercial runs of *S. glomerata* spat (O'Connor *et al.* in press).

More than 30 million oysters selected for faster growth have been purchased by the Australian Sydney rock oyster industry since 2003. This is the first time that this industry has cultivated selectively bred oysters. To assist industry adoption of selectively bred oysters, NSW DPI

monitored growth and survival of the most advanced fifth generation breeding line (Line 2) at seven locations spread throughout NSW. This study differs from previous evaluations of oysters selected for faster growth in that oysters used in this study were grown under commercial conditions by oyster growers who selected the culture methods for single seed growout of the experimental oysters.

4.7.2. Methods

4.7.2.1. Broodstock

Broodstock used to produce selectively bred spat (referred to as 'Line 2' oysters hereafter) were progeny of the fourth generation from the best performing fast growth breeding line (Line 2, Nell and Perkins, 2005). Spat produced for comparison of growth and survival were from naturally caught and cultivated wild *S. glomerata* broodstock obtained from oyster growers located at Port Stephens, the Manning River, Nambucca River and Camden Haven River (Figure 1). These oysters are referred to as 'Control' oysters hereafter.

Both oyster types were spawned on 3 December 2003 at the NSW DPI Port Stephens Fisheries Centre (PSFC) and the resultant larvae and spat were reared separately using techniques outlined in O'Connor *et al.* (In Press). By 15 January 2004, Line 2 and Control oyster spat had an average shell height of approximately 1000 μm and were sent from the PSFC bivalve hatchery to eight land-based nurseries in NSW with upweller systems located at: the Camden Haven River; Port Stephens; the Shoalhaven River; Clyde River; Wagonga Inlet; Bermagui River; Merimbula Lake; and, Pambula Lake (Figure 1). Spat remained in the land-based nurseries until early March 2004 at which time the average shell height was approximately 5 mm. At this size, *S. glomerata* spat can be transferred to fine mesh trays, cylinders or baskets for estuary growout. Experimental spat were distributed in March 2004 to the seven field sites.

4.7.2.2. Field sites and oyster management

The seven experimental field sites used in this study to compare growth and mortality between the two oyster types were: Kalang River; Camden Haven River; Wallis Lake; Shoalhaven River; Lake Conjola; Wagonga Inlet; and, Merimbula Lake (Figure 1). These seven locations were selected so that field sites were widely spread throughout the most productive range for *S. glomerata* in NSW.

This study aimed to test Line 2 oysters cultivated under commercial conditions; therefore, participating oyster growers selected the methods and management techniques for both single seed nursery rearing and growout of the adult oysters. At each field site, Line 2 and Control oysters were farmed at the same locations using the same culture methods over the entire study. Where one type of oyster reached a stage of development that required a change in culture method or specific treatment, the same change or treatment was applied to the alternative type when it had reached that stage. The management history and culture methods for Line 2 and Control oysters are recorded in Table 1.

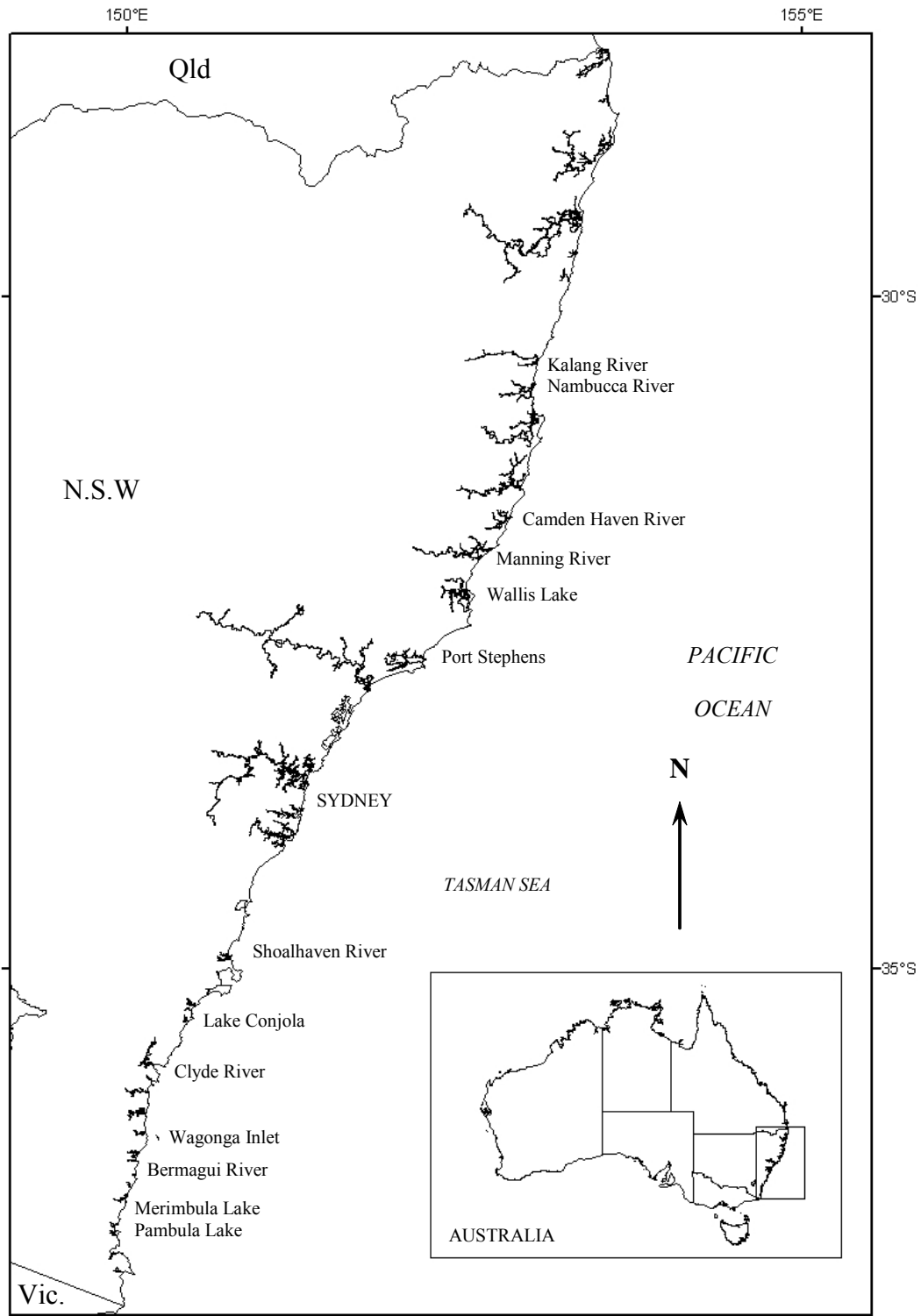

Figure 1. Map of the NSW coast showing locations of estuaries where farming sites were located.

Table 1. Culture methods for Line 2 and Control *Saccostrea glomerata* oysters grown by commercial oyster growers in NSW from March 2004 to June 2006.

Estuary	Nursery Culture			Growout Culture		
	Culture Method	Initial Stocking Density (L)	Comments	Culture Method	Month Line 2 Oysters > 50 g (time in months)*	Comments
Kalang River	Subtidal Trays (930 x 940 x 100 mm) lined with fine mesh bags	1	Transferred into 8 mm and 3 mm cylinders in Jul. 2004	Intertidal Cylinders	Jun. 2006 (30)	Oysters graded quarterly and placed into progressively larger mesh cylinders. Oysters farmed in size grades in cylinders and placed into subtidal trays in Nov. 2005.
Camden Haven River	Intertidal Trays (1800 x 910 mm) with fine mesh insert	0.5	Transferred to cylinders in Jul. 2004	Intertidal Trays (1800 x 910 mm)	Nov. 2005 (23)	Oysters transferred from cylinders into intertidal mesh trays in Oct 2004. Oysters worked quarterly, numbers thinned and placed onto progressively larger mesh trays.
Wallis Lake	Intertidal Trays (1800 x 910 mm) with fine mesh (1.7 mm) insert	2	Transferred into 8 mm trays in Oct. 2004	Intertidal Trays (1800 x 910 mm)	Mar. 2006 (27)	Oysters were graded or thinned quarterly and placed onto progressively larger mesh intertidal trays.
Shoalhaven River	Intertidal Cylinders (approx. 2mm)	1.5	Transferred to 8 mm trays in Jul. 2004	Intertidal Trays (1800 x 910 mm)	Jun. 2006 (30)	Oysters were graded or thinned quarterly and placed onto progressively larger mesh intertidal trays.
Lake Conjola	Intertidal Cylinders (approx. 2mm)	1	Transferred to pillow baskets in Oct. 2004	Intertidal Pillow Baskets	Jun. 2006 (30)	Oysters were moved from cylinders into pillow baskets when retained on Xmm mesh. Oysters farmed in size grades in the pillow baskets. Mortality event (cause unknown) in April 2005.
Wagonga Inlet	Intertidal Cylinders (approx. 2mm)	0.2	Transferred to trays (lined with mesh bags) Jul. 2004	Intertidal Trays (9 x 3 ft)	Mar. 2006 (27)	Oysters were graded initially and then thinned quarterly and placed onto progressively larger mesh intertidal trays.
Merimbula Lake	Intertidal Cylinders (approx. 2mm)	2	Moved into Aquapurses when 8 mm retained for growout from Oct. 2004	Intertidal Aquapurses	Feb. 2007 (38)	Oysters graded or thinned quarterly and placed into progressively larger mesh Aquapurses.

* Line 2 oysters were spawned 3 Dec. 2003 and all estuaries received stock in Mar. 2004

At the start of the experiment, a single tray or cylinder per oyster type held all of the experimental oysters. As oysters increased in size and size became more variable, several experimental cylinders, trays or baskets were used, some containing single size grades. At times during the experiment, a randomly selected subsample of experimental oysters was removed to reduce the numbers of experimental trays, cylinders or baskets needed. In the latter stages of the experiment, one tray or multiple cylinders of each type of oyster contained sufficient numbers of oysters for measurements.

Oyster growers recorded information about the management of both types of oysters during the study. This included information about the culture method, initial stocking density, dates on which grading or reductions in density (thinning) occurred and treatments used to reduce and control overcatch and fouling.

4.7.2.3. *Sampling strategy*

In April 2004, a subsample of 200 of each type of oyster was measured for whole weight and shell height at each of the seven sites. Approximately every 3 months thereafter, 200 Line 2 and Control oysters were randomly selected for whole weight and shell height measurements. Where oysters were farmed in different size grades, sampling involved randomly selecting a proportionate volume based on the total volume for that size grade.

Oyster mortality was estimated by counting the number of empty oyster shells in a random subsample of 50 oysters. This process was repeated four times. After mortality was estimated all empty shells were removed from the experimental trays or cylinders. Quarterly sampling continued at each site until Line 2 oysters reached an average whole weight of 50 g in order to determine the time required to produce a quality, marketable-sized oyster for sale.

4.7.2.4. *Statistical analyses*

Two factor ANOVA (Site, random factor with seven levels; and, Type, fixed factor with two levels) was used to compare whole oyster weight data and shell height data measured in March 2006 and cumulative mortality data measured July 2006. Two factor ANOVA (same factors as above) was also used to compare whole oyster weight data when Line 2 oysters reached 50 g at each of the seven sites. Cochran's C test was used to test for homogeneous variances. Cumulative mortality data was log natural transformed for homogeneity of variance. STATGRAPHICS Plus V4.1 (Manugistics Inc., USA) was used for statistical analyses.

4.7.3. **Results**

4.7.3.1. *Whole oyster weight*

Line 2 oysters were 29.3 months in age on average at all sites when they reached the 50 g benchmark. This equates to 26 months of estuarine on-growing for oyster farmers once they have received the stock at approximately 5 mm in size. Line 2 oysters at Camden Haven reached 50 g after only 20 months of estuarine grow-out, approximately four months before Line 2 oysters in Wagonga Inlet and Wallis Lake (Figure 2). The slowest oyster growth was measured at Merimbula which was the southernmost estuary in this study. Oysters at this site didn't reach 50 g until February 2007.

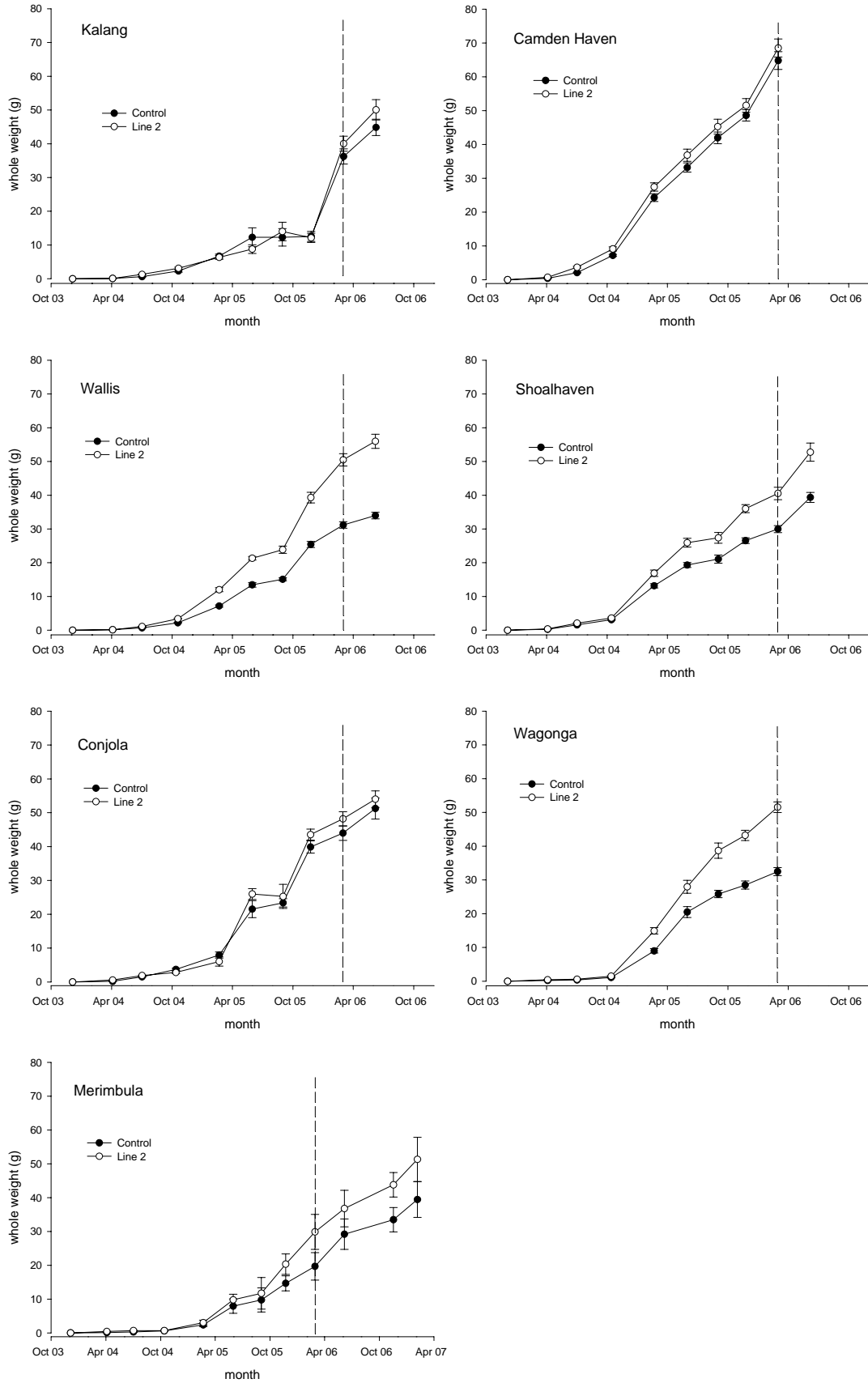

Figure 2. Whole oyster weight of Control and Line 2 *S. glomerata* farmed by oyster growers in seven estuaries in NSW.

Whole weight data for Control and Line 2 oysters were compared across all sites when Line 2 oysters had reached 50 g at each site. There was a significant difference in whole weights detected between the factors Site ($F = 56.64$; $df = 6/857$; $P < 0.001$) and Type ($F = 220.33$; $df = 1/857$; $P < 0.001$) as well as a significant interaction between Site and Type ($F = 17.3$; $df = 6/857$; $P < 0.001$). Whole weight data for Control and Line 2 oysters were also compared in March 2006 when all oysters were 27 months in age. Similarly, there were significant differences in oyster whole weight for the factor Site ($F = 252.16$; $df = 6/970$; $P < 0.001$) and Type ($F = 196.44$; $df = 1/970$; $P < 0.001$) and there was a significant interaction between Site and Type ($F = 14.82$; $df = 6/970$; $P < 0.001$).

The sites at which the largest differences in whole weight were measured between the two types of oysters were: Wallis Lake; Shoalhaven; and, Wagonga Inlet (Figure 2). Differences between the two types were less evident at Kalang River, Camden Haven River, Lake Conjola and Merimbula Lake (Figure 2). Oyster whole weight increases slowed during the winter months (June, July and August) at all sites, but was particularly noticeable at Kalang River, Wallis Lake, Shoalhaven River, Lake Conjola and Merimbula Lake (Figure 2).

Kalang River Control and Line 2 oysters had a large increase in whole weight and shell size between November 2005 and April 2006 (Figure 2). After November 2005 oysters were transferred from intertidal cylinders to subtidal trays. Oysters at Lake Conjola also gained considerable weight between February 2005 and February 2006. This was attributed to two separate events: the first was a mortality event (cause unidentified) (Figure 4) which occurred in April 2005 causing losses of 50% in experimental oysters; secondly, Control and Line 2 oysters held in baskets were washed away during flooding in October 2005. Remnant oysters were used after both events to continue measurements at this site for the duration of the experiment.

4.7.3.2. Shell height

Shell height data measured between April 2004 and July 2006 are shown in Figure 3. The shell height data collected in March 2006 for Control and Line 2 oysters were compared and there were significant differences across sites ($F = 210.12$; $df = 6/2508$; $P < 0.001$) and type ($F = 580.34$; $df = 1/2508$; $P < 0.001$). Additionally, there was a significant interaction between these two factors ($F = 20.85$; $df = 6/2508$; $P < 0.001$) on this date.

At all sites shell height increases in both oysters types tapered off once oysters had reached a shell height of between 50 – 70 mm (Figure 3). Increases in oyster shell heights during the winter months (June, July and August) were noticeably reduced at: Lake Conjola; Merimbula Lake, particularly in 2004; and, Merimbula Lake (Figure 3).

The sites at which the largest differences in shell height were measured between the two types of oysters were: Wallis Lake; Shoalhaven River; Lake Conjola; Wagonga Inlet; and Merimbula Lake (Figure 3). Differences in shell height between the two types of oysters were less evident at Kalang River and Camden Haven River. The large increase in shell height at Lake Conjola between February 2005 and February 2006 was attributed to the two events mentioned in the previous section.

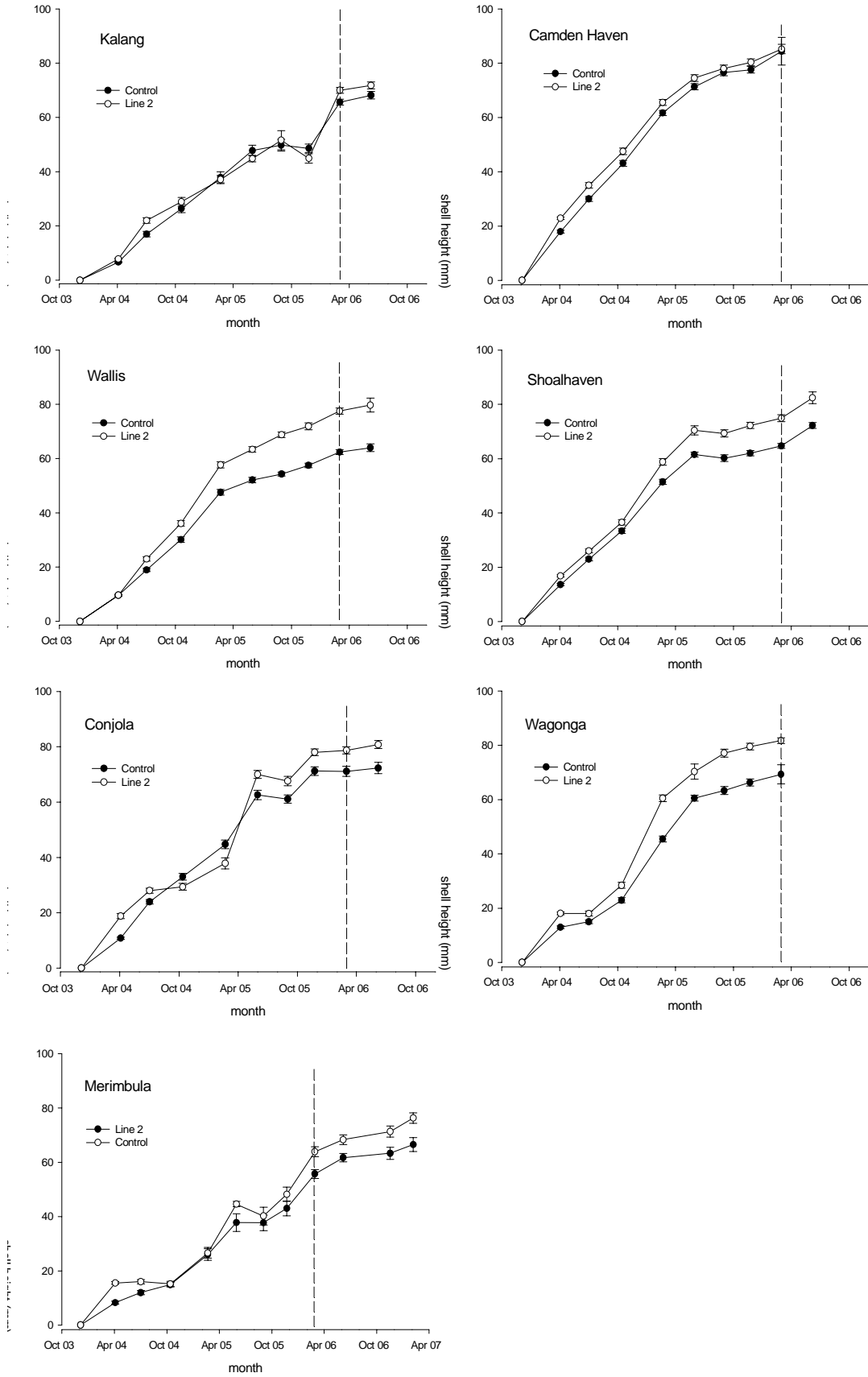

Figure 3. Shell height (mm) of Control and Line 2 *S. glomerata* farmed by oyster growers in seven estuaries in NSW.

4.7.3.3. *Cumulative mortality*

In July 2006 there was a significant difference in cumulative mortality (%) at the seven sites ($F = 21.58$; $df = 6/55$; $P < 0.001$). No significant difference in cumulative mortality was detected between Control oysters and Line 2 oysters ($F = 1.85$; $df = 1/55$; $P > 0.05$) on this date. However, there was an interaction ($F = 2.57$; $df = 6/55$; $P < 0.05$) between the two factors, site and type on this date.

By July 2006, the cumulative mortality level was between 15 and 30% at Kalang River, Wallis Lake, Shoalhaven River and Wagonga Inlet (Figure 4). Camden Haven River had a mean cumulative mortality level in Control and Line 2 oysters of 67% and 58%, respectively (Figure 4). Lake Conjola also had a high cumulative mortality level at the end of the experiment in Control and Line 2 oysters (74% and 80%, respectively) due to significant losses of oysters in April 2005 (Figure 4). Moribund oysters from this event were examined using histopathology, however, no causative factors were identified.

Line 2 oysters had a marginally higher level of mortality compared to Control oysters at Wallis Lake and Lake Conjola, whereas, at the Shoalhaven River and Merimbula Lake sites there was a more pronounced difference between Line 2 and Control oysters (Figure 4). At the two latter sites, higher mortality levels in Line 2 oysters were measured throughout the entire experiment (Figure 4). Mortalities at Merimbula Lake in September 2005 were mostly in the smallest size grade. However, during the following visit (December 2005), mortalities were spread across all sizes of Line 2 oysters. Mortalities of Line 2 oysters at Shoalhaven River were also measured across all size classes.

4.7.4. *Discussion*

Line 2 oysters reached market size (50 g) within 29.3 months on average across all sites. This result was similar to the time taken by progeny of the fourth generation stock selected for fast growth that were evaluated at three sites in Port Stephens between July 2001 and July 2004 (Nell & Perkins 2005). The average time taken for all four lines to reach market size in Nell and Perkins' (2005) study was 28.5 months and ranged between 26 months (Line 2) and 30 months (Line 1) at the three sites. The present study differed from Nell and Perkins' (2005) study in three ways. Firstly, the present study used fifth generation parent stock from Line 2 whereas Nell and Perkins (2005) used parent stock from the four fourth generation selection lines. Secondly, the present study used seven different estuaries spread over a wide geographic range while Nell and Perkins (2005) used sites only in one estuary (Port Stephens). Thirdly, the present study was conducted under commercial conditions which allowed oyster growers to use their own cultivation methods and management techniques. Oysters used in Nell and Perkins' (2005) study were handled and grown using the same culture methods at all the experimental sites.

Significant differences were detected for growth and mortality across sites and there was an interaction between site and type for both growth and mortality. Differences in management of stock, growing method, water quality and food availability at each experimental site can explain this result. Throughout the study and at all sites, oysters were handled approximately every three months when measurements were done. Stocking densities were determined by individual growers and varied from site-to-site throughout the experiment (Table 1). Likewise, culture methods at different stages of production differed between sites. Intertidal culture was used at all sites apart from Kalang River where subtidal culture was used for all stages of production (Table 1). Fine mesh trays and cylinders were used for nursery culture and cylinders, trays and baskets (suspended on line or between racking) were used to growout oysters (Table 1). The combination of different stocking densities and culture methods used at each site are likely to contribute to the difference found between sites.

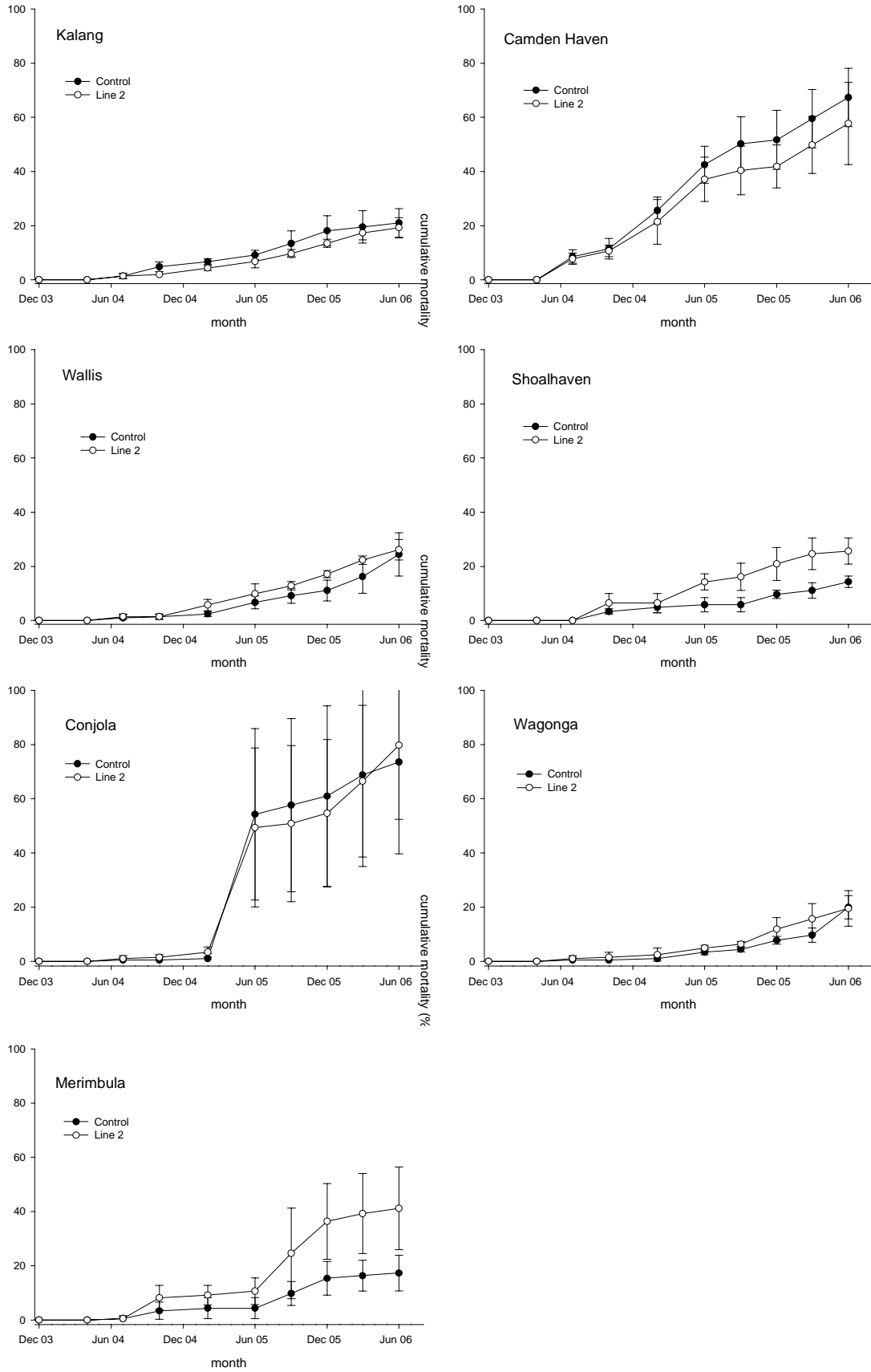

Figure 4. Cumulative mortality (%) of Control and Line 2 *S. glomerata* farmed by oyster growers in seven estuaries in NSW from April 2004 to July 2006.

The broodstock used to produce the first generation of Line 2 oysters were selected from Port Stephens, the Manning River, the Camden Haven River and the Nambucca River (Figure 1). These estuaries are geographically close to one another (Figure 1) within the Sydney rock oyster's main cultivation range. Initial selection of broodstock from these three sites for fast growth could potentially cause an interaction between genotype and environment. The effect of this would be that selectively bred oysters performed better at certain sites or under particular cultivation methods (Evans & Langdon 2006). A genotype x environment interaction in this study could be another factor causing variable performance of Line 2 oysters at the seven sites.

Salinity and temperature of estuaries used in this study range between 0 ppt (fresh) and 38 ppt and 10 and 30°C (Wolf and Collins, 1979). Estuaries located in the southern portion of NSW have lower mean and minimum temperatures (Table 2) (Wolf and Collins, 1979). Salinity of estuaries varies spatially and temporally and is influenced by many factors including: climate; estuarine bathymetry; tidal hydrology (exchange and attenuation); freshwater inflows; and, location. Temperature and salinity data collected by Wolf and Collins (1979) for estuaries used in this study are summarised in Table 2. Although conditions that influence salinity and temperature may have changed since Wolf and Collins (1979) collected these data, Table 2 shows the variability in temperature and salinity between estuaries used in the present study. Merimbula Lake was the southernmost estuary and had the lowest minimum water temperature measured by Wolf and Collins (1979) of all the sites. This would impact the rate of oyster growth at this site.

Table 2. Available temperature and salinity information (1966 – 1973) from Wolf and Collins (1979) for field sites used in this study.

Estuary	Temperature (°C) mean (min. - max.)	Salinity (ppt) mean (min. - max.)
Kalang River	nd	nd
Camden Haven River	20.5 (13.0 - 30.0)	30.7 (0 - 39.4)
Wallis Lake	20.0 (11.0 - 28.0)	30.5 (0 - 38.4)
Shoalhaven River	18.2 (10.0 - 28.0)	29.0 (0 - 38.4)
Lake Conjola	nd	nd
Wagonga Inlet	18.5 (10.0 - 29.0)	35.4 (0 - 38.7)
Merimbula Lake	17.0 (6.3 - 29.8)	34.7 (0 - 38.6)

nd = no data available for these estuaries.

Average cumulative mortality levels at Kalang, Wallis, Shoalhaven and Wagonga inlet were similar to 23% for both oyster types measured by Nell and Perkins (2005). Cumulative mortality was much higher than this at Camden Haven, Lake Conjola and Merimbula Lake. In April 2005, there was a mortality outbreak in experimental oysters at Lake Conjola. Mortality was highest in the largest grade and moribund oysters were sampled and submitted for histopathology. No cause or causes for the oyster mortality was identified. Mortality levels at Camden Haven were high throughout the experimental period and more oysters died in the late summer and spring period. Mortality was higher in the Control oysters at this Site. Conversely, at Merimbula, oyster mortality was higher in Line 2 oysters compared to Control oysters and occurred following winter in the first and second year of the experiment with the second winter being far worse than the first. Merimbula Lake recurrently suffers from winter mortality disease caused by *Bonamia roughleyi* and deaths of oysters from this disease more commonly occur in older oysters and in the months that follow winter (Wolf 1967).

Faster growing oysters can reduce handling costs incurred by growers and lessen the risk of loss of stock to disease because of the reduced growing time required. However, it is imperative that fast growing oysters are readily accepted by the market. Size and whole weight are not the only measures that determine when oysters can be sold. Once oysters are greater than 20 g, reproductive condition is the key attribute that dictates when and the duration that oysters can be sold. The authors are presently investigating the effect of selection for fast growth on oysters' reproductive condition using a range of measures and multiple sites.

The timing of commercial hatchery runs is important as it can also reduce the time taken to grow an oyster to a marketable size (Nell & Perkins 2005). Hatchery runs conducted during late winter and early spring ensures that spat are delivered to oyster growers as estuarine water temperatures increase allowing young spat to utilise the warmer water temperatures for growth (Hand *et al.* 1998). This present study was not able to get spat to growers until early autumn when estuarine temperatures are generally decreasing. Triploid induction is another method to further decrease the growing time for Sydney rock oysters as the faster growth obtained from this process compliments faster growth from selective breeding (Hand *et al.* 2004). However, brown discolouration of the gonad surface in triploid *S. glomerata* has previously affected market acceptance of these oysters (Hand & Nell 1999).

The key objectives of this study were to evaluate the performance of oysters selectively bred for faster growth under commercial conditions and assist the Sydney rock oyster industry with adoption of hatchery produced selectively bred spat. Across all sites, selectively bred oysters grew significantly faster, in terms of shell size and whole weight, compared to Control oysters. Furthermore, there was not a significant difference in cumulative mortality between Line 2 and Control oysters across all sites.

Oyster growers need to rear hatchery produced spat from a smaller starting size than naturally caught, wild, single seed Sydney rock oysters. Land-based nurseries assist in growing hatchery spat to a size for estuarine growout, however, oyster growers still receive stock smaller than what they have traditionally handled. Oyster growers participating in this study discovered that frequent (<3 months) handling of hatchery stock was necessary, particularly during the initial stages of estuarine cultivation, to achieve the best growth performance. Regular grading and/or thinning reduced density related competition amongst oysters and gave an opportunity for oysters to be upgraded to trays, baskets or cylinders with greater mesh sizes.

4.7.5. *References*

- Bayne, B.L., S. Svensson & J. Nell. 1999. The physiological basis for faster growth in the Sydney rock oyster, *Saccostrea commercialis*. *Biological Bulletin*, 197:377–387.
- Evans, S. & C. Langdon. 2006. Effects of genotype x environment interactions on the selection of broadly adapted Pacific oysters (*Crassostrea gigas*). *Aquaculture*, 261: 522–534.
- Hand, R.E. & J.A. Nell. 1999. Studies on triploid oysters in Australia XII. Gonad discolouration and meat condition of diploid and triploid Sydney rock oysters (*Saccostrea commercialis*) in five estuaries in New South Wales, Australia. *Aquaculture*, 171:181–194.
- Hand, R.E., J.A. Nell & G.B. Maguire. 1998. Studies on triploid oysters in Australia X. Growth and mortality of diploid and triploid Sydney rock oysters, *Saccostrea commercialis* (Iredale and Roughley). *Journal of Shellfish Research*, 17:1115–1127.
- Hand, R.E., J.A. Nell & P.A. Thompson. 2004. Studies on triploid oysters in Australia XIII. Performance of diploid and triploid Sydney rock oyster, *Saccostrea glomerata* (Gould, 1850), progeny from a third generation breeding line. *Aquaculture*, 233:93–107.

- Heasman, M.P., L. Goard, J. Diemar & R.B. Callinan. 2000. Improved early survival of molluscs: Sydney rock oyster (*Saccostrea glomerata*). NSW Fisheries Final Report Series: 29. Nelson Bay. 63 pp.
- Nell, J.A. & B. Perkins. 2005. Evaluation of progeny of fourth generation Sydney rock oyster *Saccostrea glomerata* (Gould 1850) breeding lines. *Aquaculture Research*, 36:753–757.
- Nell, J.A. & B. Perkins. 2006. Evaluation of the progeny of third-generation Sydney rock oyster *Saccostrea glomerata* (Gould 1850) breeding lines for resistance to QX disease *Marteilia sydneyi* and winter mortality *Bonamia roughleyi*. *Aquaculture Research*, 37:693–700.
- Nell, J.A. 1993. Farming the Sydney Rock Oyster (*Saccostrea commercialis*) in Australia. *Reviews in Fisheries Science*, 1:97–120.
- Nell, J.A., A.K. Sheridan & I.R. Smith. 1996. Progress in a Sydney rock oyster, *Saccostrea commercialis* (Iredale and Roughley), breeding program. *Aquaculture*, 144:295–302.
- Nell, J.A., I.R. Smith & A.K. Sheridan. 1999. Third generation evaluation of Sydney rock oyster *Saccostrea commercialis* (Iredale and Roughley) breeding lines. *Aquaculture*, 170:195–203.
- Nell, J.A., I.R. Smith & C. C. McPhee. 2000. The Sydney rock oyster *Saccostrea glomerata* (Gould 1850) breeding programme: progress and goals. *Aquaculture Research*, 31:45–49.
- NSW Department of Primary Industries. 2005. Aquaculture Production Report 2003/2004. NSW Department of Primary Industries, Port Stephens Fisheries Centre. 20pp.
- O'Connor, W.A., M.C. Dove, B. Finn & S. O'Connor. 2008. Hatchery Manual for Sydney Rock Oysters, *Saccostrea glomerata*. NSW DPI Final Report Series: 11. Nelson Bay. 53 pp.
- Wolf, P. 1967. Winter mortality hits the state's oyster output. *The Fisherman*, 2:9–20.
- Wolf, P.H. & A.J. Collins. 1979. Summary of Daily Temperature and Salinity Records for Major Oyster-Bearing Estuaries of New South Wales 1966 – 1973. NSW State Fisheries. 107 pp.

4.8. Gonad development of fifth generation Sydney rock oysters *Saccostrea glomerata* selected for fast growth

4.8.1. Introduction

Sydney rock oyster production is the largest and oldest aquaculture industry in NSW generating approximately \$36 million annually (NSW Department of Primary Industries 2007). The industry has experienced production declines since the mid 1970s attributed to disease, water quality issues and competition from faster growing oyster species. The Pacific oyster, *Crassostrea gigas*, can grow twice as fast as a Sydney rock oyster and directly competes with Sydney rock oyster market share in Australia. A shorter cultivation period for oysters to reach a marketable size equates to considerable savings in production costs and also decreases the risk of stock loss. To assist the Sydney rock oyster industry reduce the time taken to grow this oyster to a marketable size, the NSW Department of Primary industries (DPI) started a breeding program in 1990 with the aim of developing faster growing Sydney rock oysters and developing winter mortality disease resistance.

One of the major achievements of the breeding program was reducing the time it takes to grow an oyster to market size (50 g) by more than 12 months (Nell & Perkins 2005). The history and gains made by the NSW DPI SRO breeding program are documented in the following studies: Nell *et al.* (1996); Nell *et al.* (1999); Hand *et al.* (2004); and, Nell & Perkins (2005). The best performing fast growth line (Line 2, abbreviated as L2) have consistently outperformed oysters from the other three fast growth lines (Nell & Perkins 2005) and was made available for commercial cultivation in 2004 through the development of reliable hatchery techniques for Sydney rock oysters (O'Connor *et al.* in press).

More than 30 million oysters selected for faster growth have been purchased by the Sydney rock oyster industry since this date. More recently, the SRO industry has requested the commercialisation of lines that incorporate QX disease and winter mortality disease resistance as well as fast growth to reduce the risk of stock losses, primarily from QX disease. The fast growth oysters purchased by industry in 2004 have been through a full production cycle and growers have observed subtle differences in the reproductive behaviour of selected line stock compared to wild stock.

Sydney rock oysters are considered suitable for sale when their gonad appears cream in colour and is turgid such that the fish fills most of the left valve. Gonadal development is affected by temperature and available food levels at cultivation sites. There are geographical differences in reproductive cycles throughout the Sydney rock oyster's production range. Generally, estuaries in the north of NSW have a marketing season from late spring through to early autumn whereas southern NSW estuaries may have saleable oysters in the summer months through to the middle of winter.

The effect of selection for fast growth and disease resistance over several generations on SROs capacity for gonadal development is not known. This study investigated condition index, gonadal development and growth of fifth generation SROs selected for fast growth over a 12 month period while oysters were being commercially cultivated. Three sites spread throughout the SROs growing range were selected and selected oysters were compared against Control oysters which were the progeny of non-selected broodstock.

4.8.2. **Materials and methods**

4.8.2.1. *Broodstock*

Broodstock to produce selected oysters was progeny of the fourth generation from the best performing fast growth breeding line (Line 2, abbreviated as L2). The oysters used for comparison, referred to as Controls, were from naturally caught, wild *S. glomerata* broodstock obtained from four oyster producing estuaries on the mid north coast of NSW (Port Stephens, Manning River, Nambucca River and Camden Haven River, Figure 1).

The oysters used in this study were from the same batch of oysters used by Dove and O'Connor (in press) to commercially assess growth and mortality of oysters selected for fast growth. Spawning and hatchery rearing techniques are detailed in O'Connor *et al.* (in press) and information about nursery rearing and estuarine growout of these oysters is contained in Dove and O'Connor (in press).

4.8.2.2. *Field sites*

In March 2004, when spat had a mean shell height of approximately 5 mm, they were distributed to three experimental field sites: Camden Haven River, Shoalhaven River and Wagonga Inlet (Figure 1). These three field sites were spread throughout the main growing range for *S. glomerata*. The shell height and whole weight of these oysters were measured at quarterly intervals at each site between April 2004 and June 2006 (Dove & O'Connor in press).

4.8.2.3. *Oyster sampling and measurements*

Between June 2005 and July 2006, approximately 24 Control and 24 L2 oysters were randomly sampled each month from experimental trays held at the three sites. No samples were collected in July 2005 and January 2006. The average (\pm SD) shell height of L2 and Control oysters in June 2005 was 65 ± 8.1 mm and 73 ± 8.3 mm, respectively. Experimental trays containing Control and L2 oysters were cultivated at the same site in each estuary. Within 24 hours of sampling, oysters were cleaned of fouling organisms, overcatch (spat caught on the shell of oysters) were removed and shell dimensions (height, length and width), whole weight, shell weight and wet tissue weight were measured. The weight data were used to calculate wet weight condition index (CI) according to the formula:

$$CI = \text{soft tissue weight (g)} \times 1000 / \text{internal shell cavity capacity (g)}$$

Where:

$$\text{Internal shell cavity capacity} = \text{whole weight (g)} - \text{shell weight (g)}$$

(Lawrence and Scott, 1982).

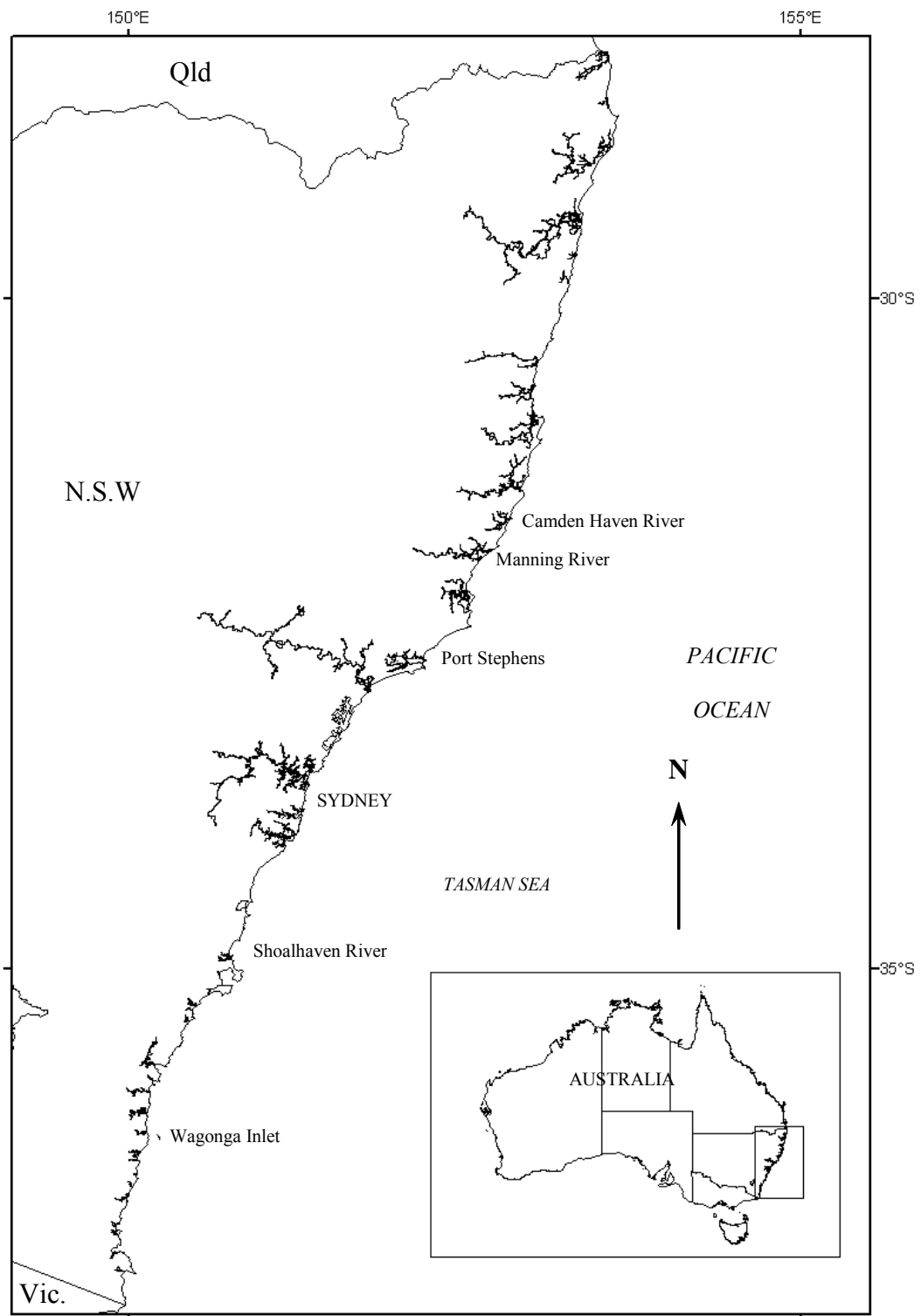

Figure 1. Map of the NSW coast showing locations of estuaries used as field sites and origin estuaries of Control oyster broodstock.

4.8.2.4. Histology

A Gonadal sample was dissected from each oyster for histologic analysis. A transverse tissue cross-section was cut from the anterior of the oyster through the gonad, intestine, digestive diverticula, stomach and labial palps at the point where the palps intersected the gills (Howard *et al.* 2004). A second cut was made 3mm below the first providing a piece of gonadal tissue which was then fixed in Davidson's fixative for 48 hours, placed in 50% ethanol, and preserved in 70% ethanol. Paraffin embedded 5 μ m sections were cut and mounted on acid washed glass slides and stained with haematoxylin and eosin (H&E). Slides were examined with an Olympus OM-2 compound stereo microscope (magnification = x 40 to x250).

Oysters were sexed and distributions of male and female oysters were compared for each oyster type at each site and between sites for both controls and L2s using cross tabulation and chi-square analysis. Stages of gonadal development were classified according to the stages described by Dinamani (1974), also used by Cox *et al.* (1996), for *S. glomerata*. Dinamani's (1974) classification scheme had 7 developmental stages that fall within 5 phases. Phase I is a ripening period (G1-G3); Phase II (G4) is when oysters are fully ripe; Phase III occurs immediately after spawning when some or all follicles had started to release gametes; Phase IV (G5) was when phagocytes were present (i.e., gonad regression) but sex is still determinable; and, Phase V is a regressive phase where gonial cells are indifferent. Micrographs and more detailed descriptions of these stages can be found in Dinamani (1974) and Cox *et al.* (1996).

4.8.3. Results

4.8.3.1. Growth

Shell height and whole weight measurements from the L2 and Control oysters collected from the three sites are displayed in Figure 2 and 3, respectively. These figures show the difference between the two oyster types over the study period. The L2 oysters were significantly larger and heavier ($P < 0.01$) than Control oysters at both the start and end of this study.

Overall, L2 oysters were significantly heavier ($F = 217.21$; $df = 1/1671$; $P < 0.001$) and larger ($F = 322.22$; $df = 1/1671$; $P < 0.001$) than Control oysters. Additionally, there were significant differences in both oyster whole weight ($F = 457.29$; $df = 2/1671$; $P < 0.001$) and shell height ($F = 287.37$; $df = 2/1671$; $P < 0.001$) between the three sites. There was a significant interaction between the factors Site and oyster Type for both whole weight and shell height.

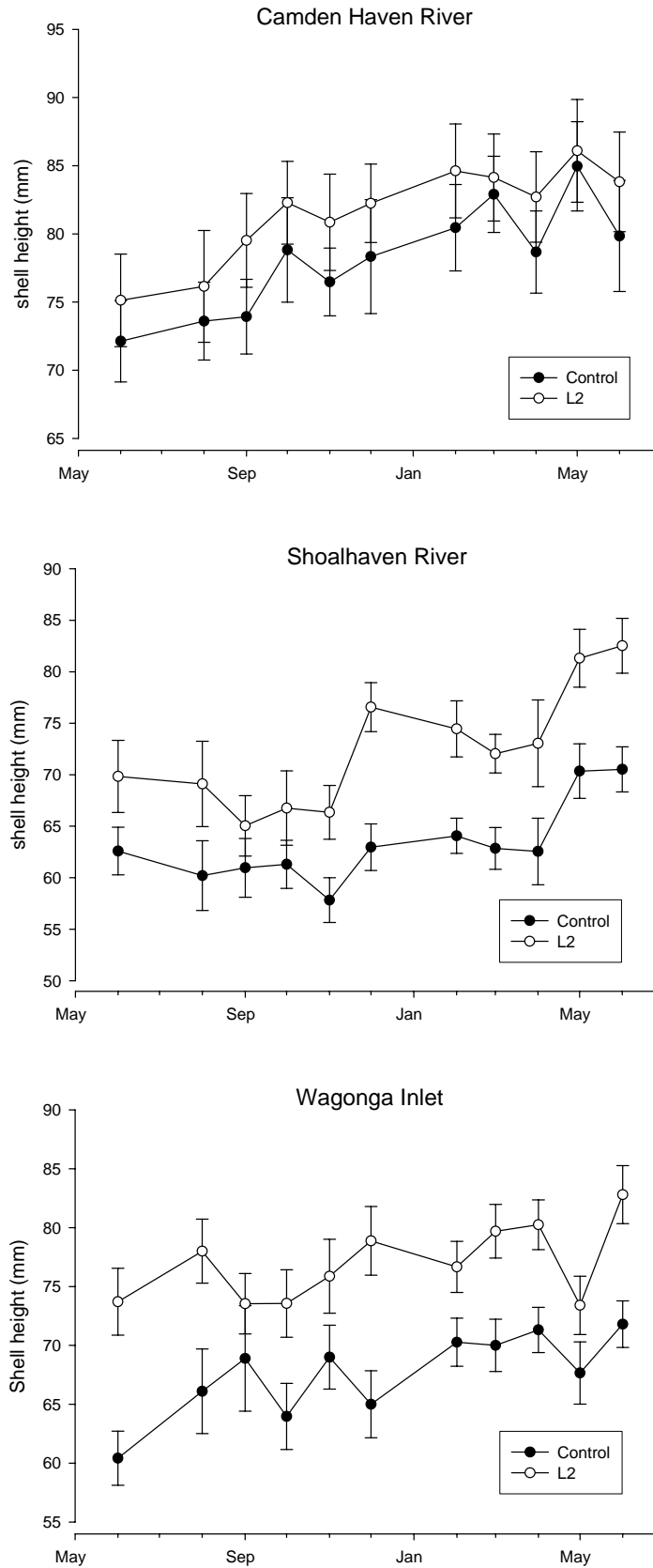

Figure 2. Shell height of L2 and Control *Saccostrea glomerata* oysters from June 2005 to June 2006 at the Camden Haven River, Shoalhaven River and Wagonga Inlet field sites.

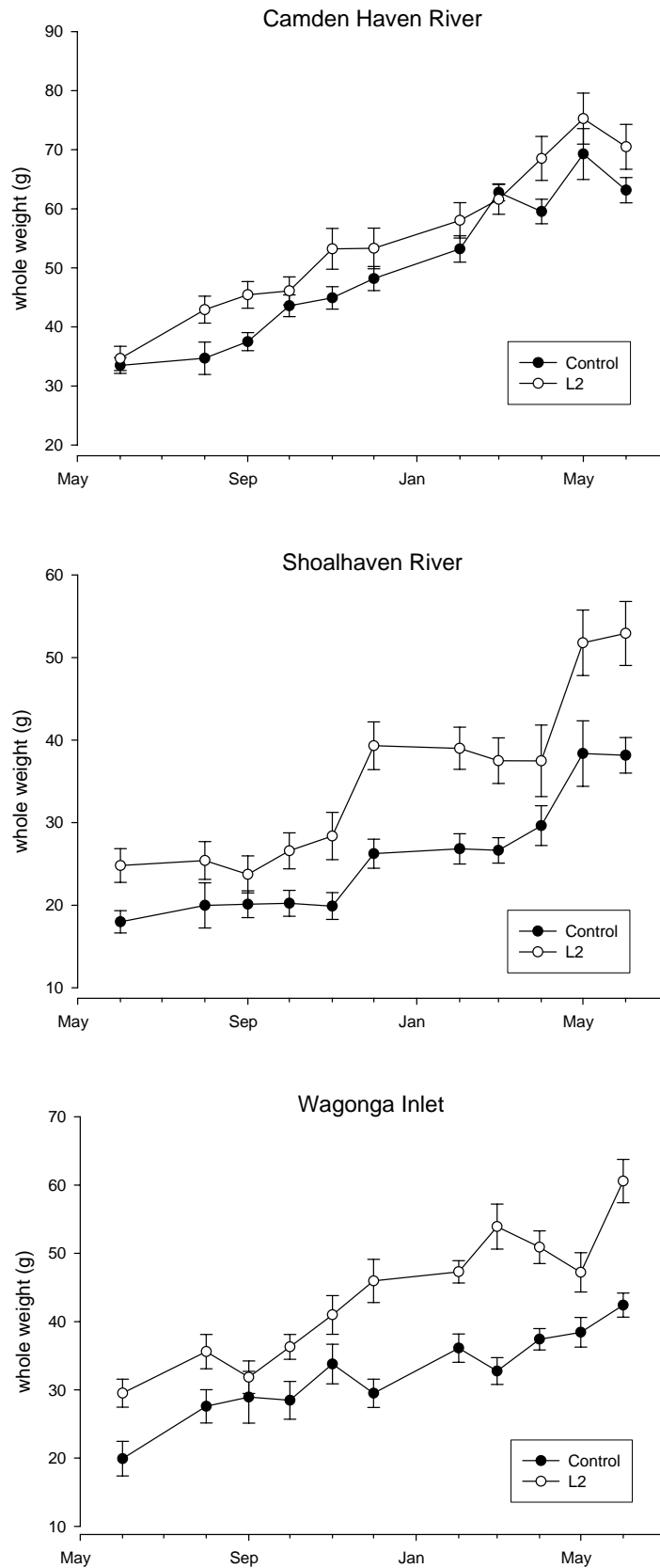

Figure 3. Whole weight of L2 and Control *Saccostrea glomerata* oysters from June 2005 to June 2006 at the Camden Haven River, Shoalhaven River and Wagonga Inlet field sites.

4.8.3.2. *Condition index*

Condition index of L2 and Control oysters at the three sites are displayed in Figure 4. There was no difference in condition index of male oysters when compared to female oysters. However, there was a significant difference in condition index between the three sites ($F = 31.36$; $df\ 2/1676$; $P < 0.001$) and when L2 oysters were compared to the Control oysters ($F = 116.23$; $df\ 1/1676$; $P < 0.001$). Additionally there was a significant interaction between these two factors ($F = 14.63$; $df\ 2/1676$; $P < 0.001$).

4.8.3.3. *Sex ratio*

The effect of oyster type on the distribution of sex

The distribution of male and female oysters was different at Camden Haven and Shoalhaven, but was similar at Wagonga. At the Camden Haven site, L2s had a greater proportion of female oysters compared to male oysters (65% to 35%, respectively), whereas, in the Control oyster group, there was a similar proportion of both males and females (49% to 51%, respectively). At the Shoalhaven site, both L2 and control groups were dominated by female oysters. 73% of Control oysters at the Shoalhaven were females, whereas, 62% of the L2 oysters at this same site were females. At Wagonga, where the distributions of males and females were similar (Pearson Chi-Square = 1.807, $df = 1$, $P > 0.05$), both types of oysters had more females. At this site, 81% of the control oysters and 73% of the L2 oysters were females.

The effect of site on the distribution of sex for control oysters

The Control oyster group at Camden Haven had a different distribution of male and female oysters compared to the other two sites (Shoalhaven and Wagonga). Shoalhaven and Wagonga had similar distributions of male and female control oysters. That is, there was no site effect on the distribution of sex between Shoalhaven and Wagonga.

As stated above, there were similar proportions of male and female control oysters at Camden Haven. However, at Shoalhaven there were many more female control oysters (73%) than male control oysters (27%). This scenario also occurred at Wagonga where 81% of control oysters were females and only 19% were males.

The effect of site on the distribution of sex for L2 oysters

At all three experimental sites, there were more female L2 oysters than male L2 oysters. The distribution of male and female L2 oysters at Camden Haven was similar to the distribution of male and female L2 oysters at Shoalhaven and Wagonga. There was a greater differential between female and male L2 oysters at Wagonga (difference of 46% between males and females) compared to Shoalhaven (difference of 24% between males and females).

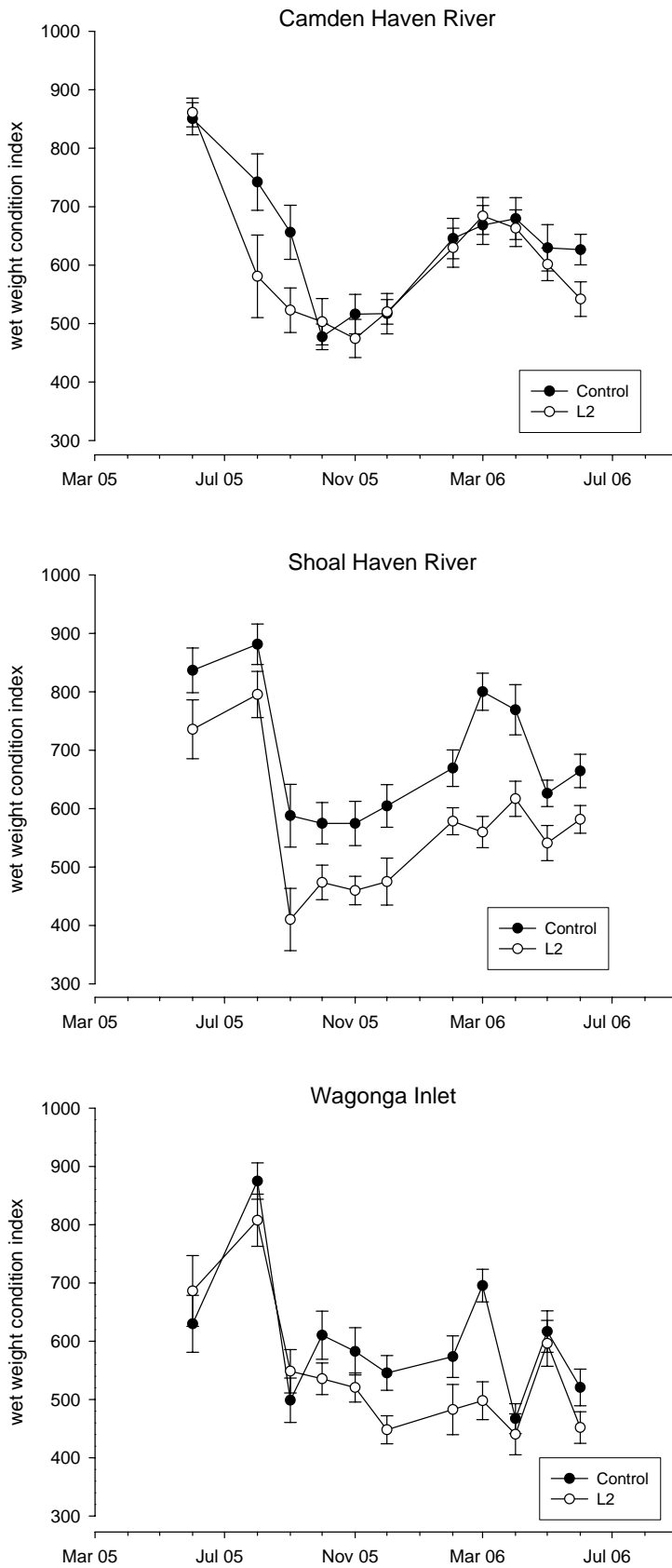

Figure 4. Shell height of L2 and Control *Saccostrea glomerata* oysters from June 2005 to June 2006 at the Camden Haven River, Shoalhaven River and Wagonga Inlet field sites.

4.8.3.4. *Reproductive condition*

Figures 5 to 7 show the percentage frequency of each gonad phase at monthly intervals over one calendar year in: the Camden Haven River (Figure 5); the Shoalhaven River (Figure 6); and, Wagonga Inlet (Figure 7). The breeding season in the Camden Haven River commenced in November 2005 and continued through to May 2006. L2 oysters at this site started to spawn in March and Control oysters started to spawn one month later in April. There was a higher proportion of Control oysters in a fully ripe stage (G4) compared to L2 oysters in November, December, February, March and April. In May there were more L2 oysters in ripe condition. Most L2 oysters maintained a post spawned state in June 2006 and did not enter into the regressive phase in the same way that Control oysters did in this month. At the start of sampling in June 2005 approximately half of the oysters were in a post spawned state which may account for the high condition index value measured at this site during this month.

There were ripe Control and L2 oysters in all of the monthly samples collected from the Shoalhaven River. The breeding season in the Shoalhaven River commenced in November – December 2005 and most oysters held a ripe or post spawned condition until May 2006. A small proportion of oysters remained ripe through August, September and October 2005.

Control and L2 oysters in Wagonga Inlet started ripening in November 2005 and maintained a fully ripe condition until March 2006. In November and December 2005, there were more control oysters in a fully ripe state in these samples. In August 2005, the L2 oysters were fully spent and most Control oysters at this time were in a partially spawned state and entered the regressive phase one month later. In June 2005, there were Control and L2 oysters in each gonadial phase.

4.8.4. *Discussion*

Although L2 and control oysters were the same age, L2 oysters were significantly larger than the control oysters they were compared against. This size difference between the two oyster types was more pronounced at the Shoalhaven River and Wagonga Inlet.

There was a mixed response in condition index between the two oyster types at the three sites. At the Camden Haven River, oysters were more evenly matched for size compared to the other two sites. The condition index of the two oyster types at the Camden Haven River was very similar for the duration of sampling. Although, between the months of June and October in 2005 the selected oysters returned a lower condition index value possibly caused by a faster and more complete spawning event compared to the control oysters.

At the Shoalhaven site, the condition index changes of the two oyster types followed the same pattern. A noticeable difference at this site throughout the experiment was oysters selected for fast growth always had a lower condition index compared to the non-selected control group. Oysters spawned after August 2005 and were mostly in a post spawned or regressive state until November 2005. After this time, the condition index of Shoalhaven oysters increased through gonadial development.

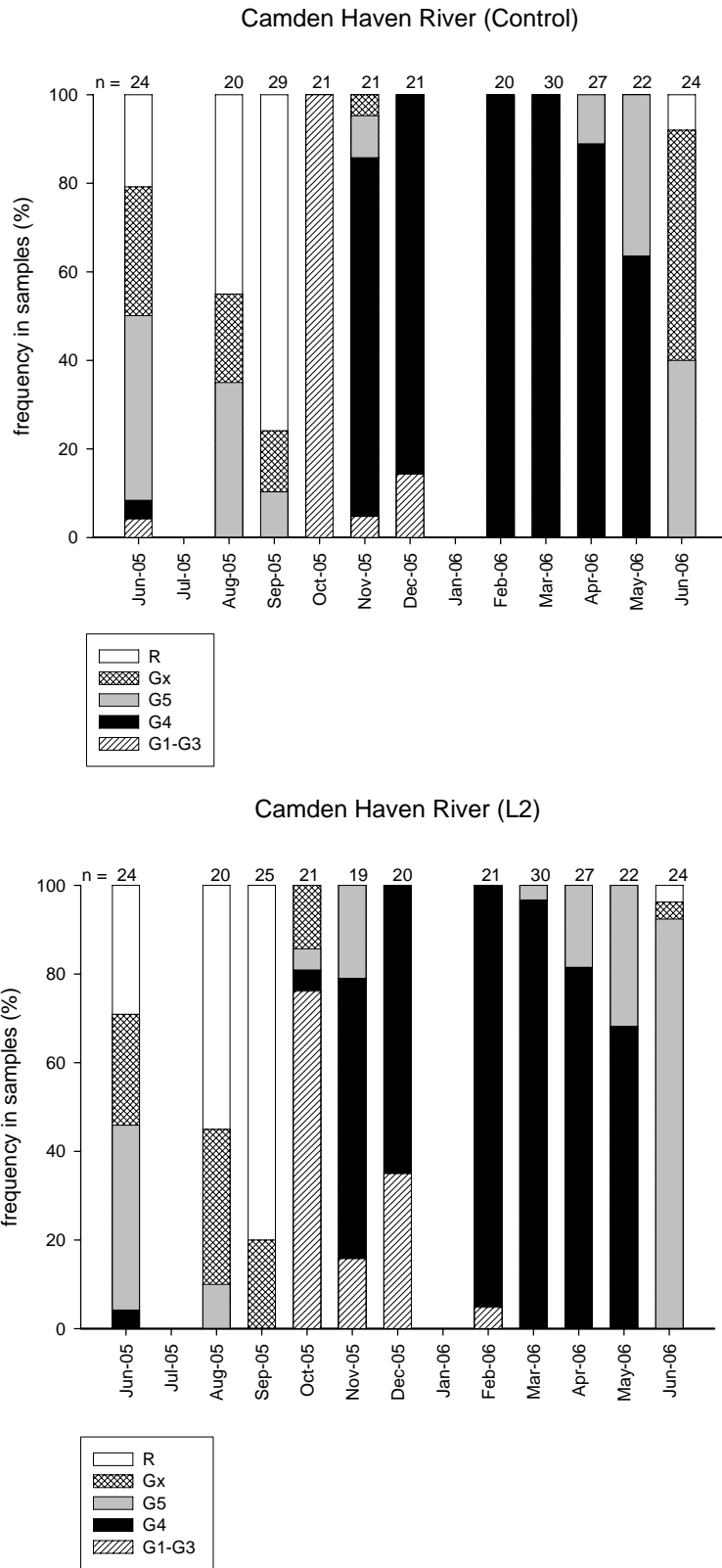

Figure 5. Monthly frequency of gonadial phases in Control (top graph) and L2 (bottom graph) *Saccostrea glomerata* oysters in the Camden Haven River, NSW, from June 2005 to July 2006. Gonadial phases based on Dinamani's (1974) categories where: G1-G3 = ripening phase; G4 = fully ripe, pre-spawning phase; G5 = post-spawning phase; Gx = early regressive phase; R = main regressive phase.

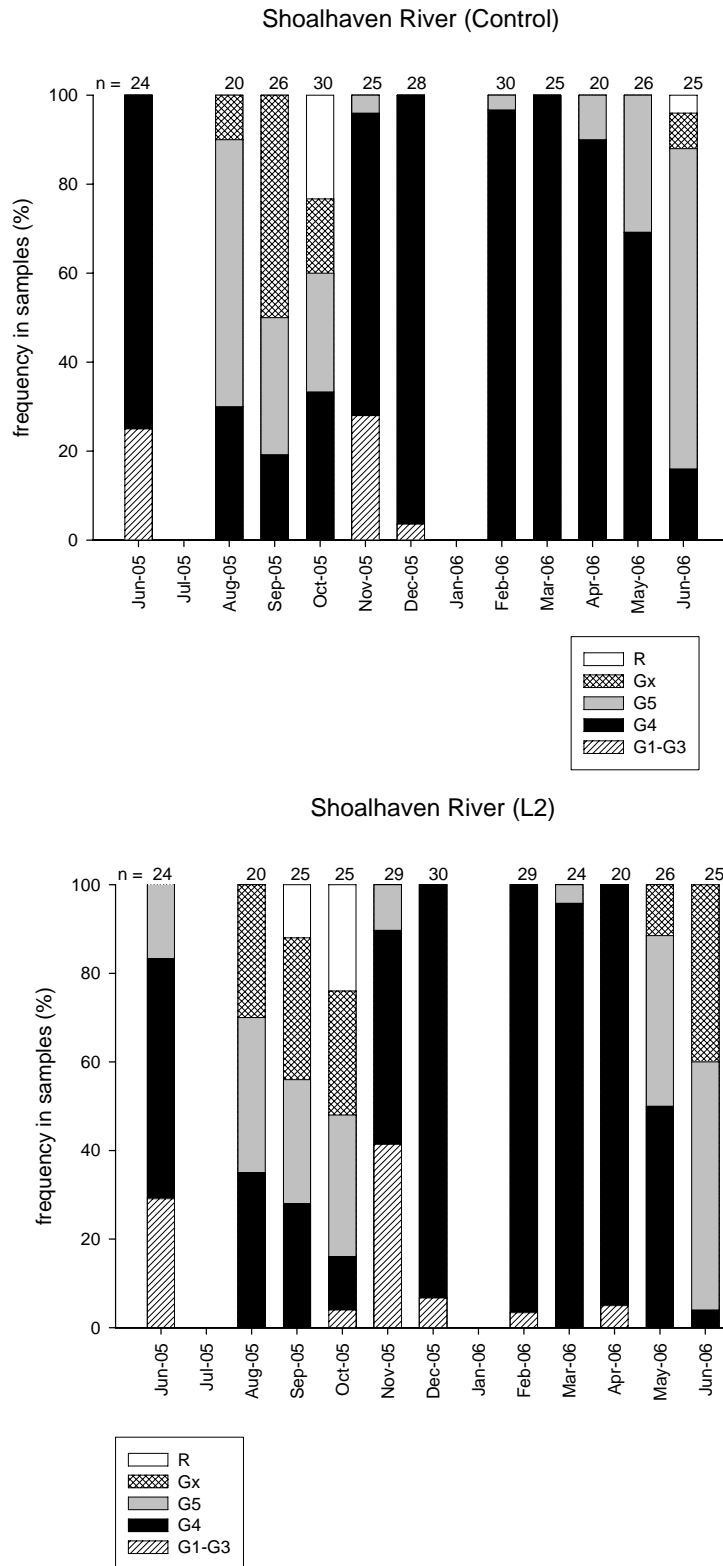

Figure 6. Monthly frequency of gonadal phases in Control (top graph) and L2 (bottom graph) *Saccostrea glomerata* oysters in the Shoalhaven River, NSW, from June 2005 to July 2006. Gonadal phases based on Dinamani’s (1974) categories where: G1-G3 = ripening phase; G4 = fully ripe, pre-spawning phase; G5 = post-spawning phase; Gx = early regressive phase; R = main regressive phase.

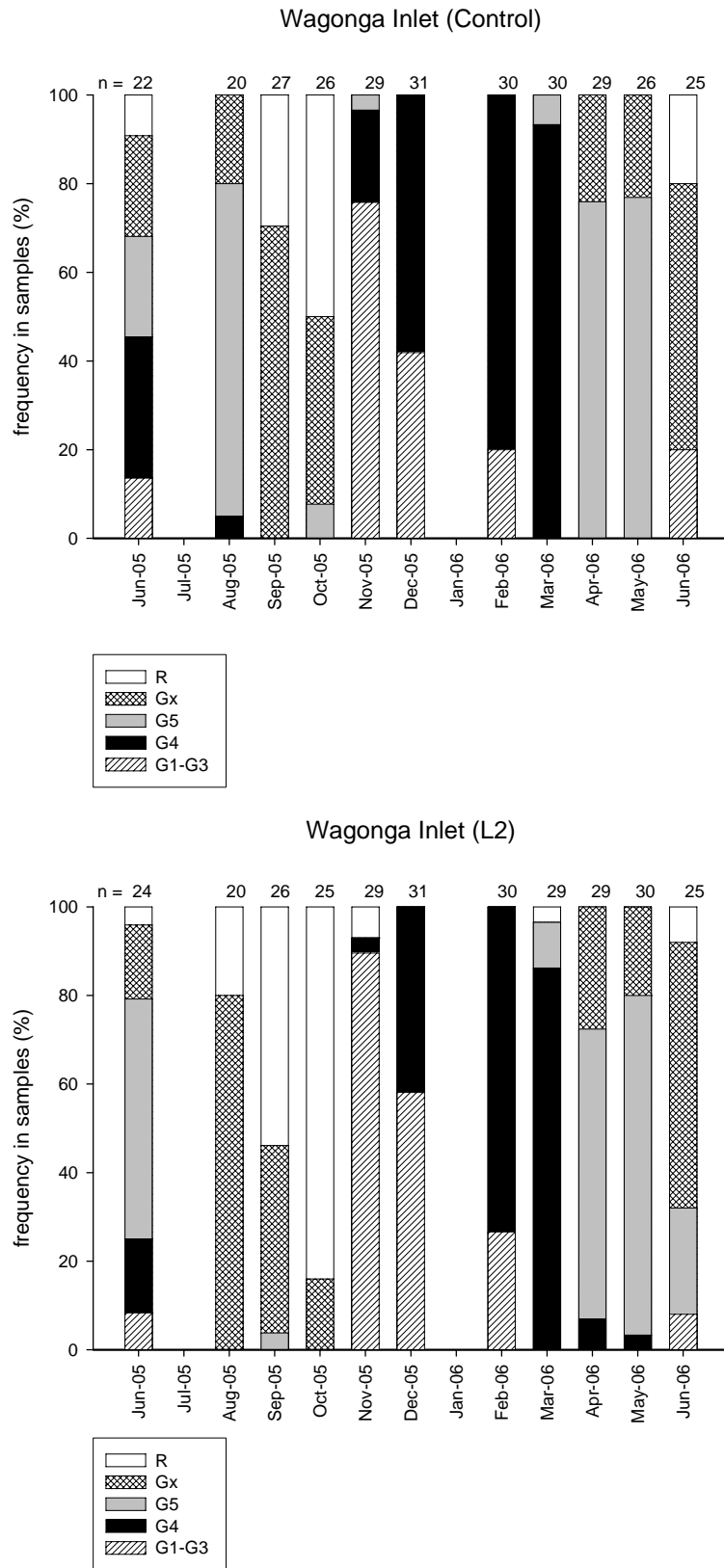

Figure 7. Monthly frequency of gonadal phases in Control (top graph) and L2 (bottom graph) *Saccostrea glomerata* oysters in Wagonga Inlet, NSW, from June 2005 to July 2006. Gonadal phases based on Dinamani’s (1974) categories where: G1-G3 = ripening phase; G4 = fully ripe, pre-spawning phase; G5 = post-spawning phase; Gx = early regressive phase; R = main regressive phase.

Both oyster types had a similar condition index in Wagonga Inlet during the first four months of the experiment. However, from October 2005 through to March 2006 selected oysters had a consistently lower condition index value and didn't condition to the same level as the control oysters in March 2006. Both types of oyster spawned in March 2006 as shown in Figure 4 and 7. After this had occurred the condition index of both types was similar through the months April, May and June 2006.

Oysters selectively bred for fast growth had a mixed response in terms of their reproductive behaviour when compared against Control oysters at the three sites.

4.8.5. **References**

- Dove, M.C. & W.A. O'Connor. In Press. Growth and mortality of fifth generation Sydney rock oysters *Saccostrea glomerata* selectively bred for fast growth.
- Dinamani, P. 1974. Reproductive cycle and gonadial changes in the New Zealand rock oyster *Crassostrea glomerata*. *New Zealand Journal of Marine and Freshwater Research*, 8:39–65.
- Cox, E.S., M.S.R. Smith, J.A. Nell & G.B. Maguire. 1996. Studies on triploid oysters in Australia. VI. Gonad development in diploid and triploid Sydney rock oysters *Saccostrea commercialis* (Iredale and Roughley). *Journal of Experimental Marine Biology and Ecology*, 197:101–120.
- Hand, R.E., J.A. Nell & P.A. Thompson. 2004. Studies on triploid oysters in Australia XIII. Performance of diploid and triploid Sydney rock oyster, *Saccostrea glomerata* (Gould, 1850), progeny from a third generation breeding line. *Aquaculture*, 233:93–107.
- Howard, D.W., E.J. Lewis, B.J. Keller & C.S. Smith. 2004. Histological techniques for marine bivalve molluscs and crustaceans. NOAA Technical Memorandum NOS NCCOS 5, 218 pp.
- Lawrence, D.R. & G.I. Scott. 1982. The determination and use of condition index in oysters. *Estuaries*, 5:23–27.
- Nell, J.A. & B. Perkins. 2005. Evaluation of progeny of fourth generation Sydney rock oyster *Saccostrea glomerata* (Gould 1850) breeding lines. *Aquaculture Research*, 36:753–757.
- Nell, J.A., A.K. Sheridan & I.R. Smith. 1996. Progress in a Sydney rock oyster, *Saccostrea commercialis* (Iredale and Roughley), breeding program. *Aquaculture*, 144:295–302.
- Nell, J.A., I.R. Smith & A.K. Sheridan. 1999. Third generation evaluation of Sydney rock oyster *Saccostrea commercialis* (Iredale and Roughley) breeding lines. *Aquaculture* 170:195–203.
- NSW Department of Primary Industries. 2007. Aquaculture Production Report 2005/2006. NSW Department of Primary Industries, Port Stephens Fisheries Centre. 20pp.
- O'Connor, W.A., M.C. Dove, B. Finn & S. O'Connor. 2008. Hatchery Manual for Sydney Rock Oysters, *Saccostrea glomerata*. NSW DPI Final Report Series: 11. Nelson Bay. 53 pp.

5. BENEFITS

The development and demonstration of reliable cost-effective hatchery production of Sydney rock oyster (SRO) seed and the subsequent adoption of that technology has potentially presented one of the greatest forces for change within the SRO industry in decades. The Australian SRO industry can now have access to selectively bred stock, have greater assurance of seed supply and develop an increased capacity for industry led development.

Oyster breeding programs in Australia are at the forefront of aquaculture selective breeding in this country and have achieved significant success in a number of areas. Selectively bred SRO stock has been produced that grow faster, are resistant to major diseases such as QX and are improving in their ability to resist other diseases such as Winter Mortality (Nell, 2005). Accessing the benefits of this research had previously been denied to the SRO industry. Building on the foundation provided by programs such as FRDC 2002/206 “Sydney rock oyster hatchery and Nursery Health Workshop”, this program has for the first time opened the door to reliable hatchery seed supply. Not surprisingly within the space of 3 – 4 years, industry has embraced hatchery seed and it now provides more than 30% of industry’s spat demand.

Hatcheries offer not only a mechanism to overcome inter-annual variability in seed supply but also a means of controlling the timing of supply. SRO farmers have traditionally had access to a reliable supply of naturally caught spat, but that supply has been constrained in recent decades. The introduction of Pacific oysters to NSW, the outbreak of QX disease and, to a lesser extent the introduction of noxious species such as the invasive seaweed *Caulerpa taxifolia*, have all placed a series of constraints on spat movement. Farmers increasingly have to cope with the possibility of spat supply shortfalls and this can be overcome through hatchery seed supply. In addition, there are advantages in accessing spat at different times within the year. Hatcheries are not constrained by normal seasonal reproductive cycles and can supply seed when required. For SRO farmers on the NSW south coast this could mean having seed much earlier in the year to make the most of the spring summer growing season, or for those in northern NSW, collecting seed later in the year to avoid “overcatch” (the settlement of other juvenile oysters) on their stock.

To date, a great deal of SRO research has been hatchery centric and as such has been largely confined to government agencies and universities. With the privatisation of hatchery production, industry has an increased capacity for self driven research. Examples of this can be seen in the Australian Pacific oyster industry where commercial companies such as Australian Seafood Industries, Shellfish Culture Limited and Camerons of Tasmania are all involved in aspects of breeding research. With the advent of the Select Oyster Company, the SRO industry has its own research vehicle.

In accordance with the relative size of the industry, it is expected that in the short to medium term the major benefit of the establishment of SRO hatchery capacity will be accrued to the NSW industry. QLD farmers however are affected by QX disease, have purchased selectively bred seed and will benefit from the availability of disease resistant spat.



A comparison of growth and survival of selectively bred QX resistant spat (foreground) and control SRO spat in the Hawkesbury River NSW in 2007 following the outbreak of QX disease.

6. FURTHER DEVELOPMENT

Since the inception of techniques for the artificial propagation of bivalves there has been steady progress in the development of techniques to increase reliability, decrease cost and broaden the array of products available to industry. Undoubtedly there will be further refinements of the techniques developed in this program to adapt to the changing needs of hatcheries and there will be adaptations to suit particular hatchery locations and environments.

The primary driver of this program, the distribution of selectively bred SRO spat, has already posed new challenges for SRO production. The evolution of the SRO breeding program to assess the potential for the incorporation of pair mated breeding lines has already introduced new needs. Foremost among these are techniques to allow mating of selected individuals (spawning induction or strip spawning) and the need for highly replicated small scale production systems.

Within the auspices of this program a number of new production techniques have been assessed, however the number of alternative techniques available (established and experimental) and the constraints placed on this research by the infrastructure present at the PSFC and at Newtech Aquaculture in Hervey Bay, have meant there are many alternatives left for evaluation. We selected from among the early rearing techniques available with the goal of establishing reliable production. However, there are still considerable potential advantages that could arise from the further assessment of other commonly used approaches such as flow-through high density culture techniques and the increased integration of improved “off-the-shelf” diets.

The current approach to SRO spat supply to industry requires restructuring. Presently, there is a tendency within industry to order spat when required and for hatchery production to be organised on a “just in time basis”. Hatchery production is not infallible and this will lead to supply difficulties. There is a need for industry to appreciate the requirement for orders to be placed well in advance of need and for hatcheries and nurseries to produce ahead of demand so that spat are available when required. For Pacific oyster seed supply in South Australia and Tasmania, a stockpile of seed is maintained through production and “overwintering” of seed in readiness for the next production season. These approaches need to be evaluated with SRO. In addition, the NSW industry needs to assure seed supply and consider additional avenues should production from Queensland fail, be unable to meet increasing needs or be restricted due to biosecurity issues.

Reliable hatchery techniques enable integration and development of new technologies that can be applied to SRO production. For example, safe and effective production techniques to create triploid SROs can be investigated and cryopreservation of SRO gametes can be evaluated for incorporation into breeding programs. This research is presently underway and is solely due to the success of this project.

7. PLANNED OUTCOMES

Outcome 1: The development of reliable techniques for hatchery and nursery production of SRO's to allow the significant benefits of culturing genetically improved and triploid oysters to flow on to the industry in NSW and Queensland.

In the course of this program we have been able to demonstrate that reliable production of SRO is possible. Previously early larval mortality occurring within 8 days of spawning has affected more than 56% of production attempts. A total of 42 production runs have been undertaken of which 38 (>90%) have reached day 8 without significant losses or symptoms of previous mortality outbreaks. Further, spat mass mortality syndrome (SMMS) has been completely absent since 2003. These results have now been mirrored at commercial facilities which have been able to produce commercial quantities of SRO seed in three successive production seasons.

Overall, more than 70 million genetically improved SRO seed have been supplied to industry. The bulk of these spat having been derived from a commercial facility.

Outcome 2: The presence of a commercial hatchery to supply industry demands for genetically improved SRO spat.

Critical to the ongoing success of this program is the presence of a commercial bivalve hatchery with the capacity to produce SRO spat. To promote the involvement of commercial interests, NSW DPI has undertaken several complementary strategies. Initially, DPI called for tenders to conduct a series of external SRO seed production trials, using NSW SRO stock and commissioned Mr Nik Duyst of New Tech Aquaculture, Hervey Bay, to undertake these trials. Mr Duyst has remained involved in this program and has been the mainstay of commercial spat supply to industry.

To allow production of SRO spat outside NSW, DPI (Research and Biosecurity Unit) has worked with Mr Duyst and other hatchery operators to establish a series of spat importation protocols that permit interstate supply of seed. These importation protocols have allowed both SRO spat from QLD to be imported to NSW as well as Pacific oyster spat to enter from Tasmania. The latter opening the pathway for existing Pacific oyster spat producers to contemplate production of SRO spat for the NSW and QLD oysters industries.

With the potential to facilitate the construction of a hatchery in NSW, NSW DPI has also called for Expressions of Interest for use of the Port Stephens, Tomaree Research Facility in cooperative research programs. The Tomaree facility has previously been used for mollusc production (abalone, scallops and oysters) and offers an opportunity for a hatchery producer to assess the viability of establishing in NSW.

Outcome 3: The promotion of direct industry involvement in spat production through farmer-operated field nurseries.

From the outset of this program, SRO farmers have actively become involved in spat production and have been entirely responsible for the production of more than 80 million spat for industry adoption. NSW DPI has provided both practical and technical support to farmers willing to attempt nursery production. A series of advisory publications have been prepared (see appendices), workshops have been held and regular farm based visits have been made by DPI staff throughout the course of this research.

8. CONCLUSIONS

This program has clearly demonstrated that previous constraints to large scale commercial supply of SRO seed can be overcome and has for the first time provided the NSW and QLD oyster industries with a reliable commercial source of genetically improved SRO spat.

Using techniques based on those described by Frankish *et al.* (1991) out-of-season conditioning and spawning of selected oyster stocks was achieved, although altered requirements for conditioning of some selected line stock were observed. Assessments of the effects of the key autecological factors (temperature and salinity) and nutrition on SRO embryos and larvae have led to modifications of previous protocols, but this research has also indicated that previous losses are unlikely to have resulted from these techniques. Rather, it is thought that incremental improvement to 1) seawater, supply, handling and delivery, 2) early larval management techniques, late larval diets and altered settlement protocols have collectively contributed to improved reliability. Although systematic assessments and monitoring of larval health for major potential pathogenic factors were undertaken, the absence of major mortality events (larval or spat) precluded the opportunity to reflect on the cause of previous problems.

There are a range of low cost alternative techniques for algal and larval and spat rearing that can enhance commercial SRO production. In particular alternative approaches for spat rearing including spat bubblers and field based nursery systems were found to offer significant improvements over previous approaches and importantly have served to increase industry involvement and understanding of the hatchery production process.

9. REFERENCES

- Benzie, J.A., R.P. Grove-Jones & R.D. Adlard. 2002. Review of hatchery production technology and breeding program for Sydney rock oysters. Final report for Fisheries Research and Development Corporation (Project 2001/213). Centre for Marine and Coastal Studies, The University of New South Wales. Sydney. 66pp.
- Frankish, K.R., L.J. Goard & W.A. O'Connor. 1991. The development of hatchery rearing techniques of the Sydney rock oyster (*Saccostrea commercialis*) at the Brackish Water Fish Culture Research Station, Salamander Bay, NSW, 2301. 26 pp.
- Heasman, M.P., L. Goard, J. Diemar & R.B. Callinan. 2000. Improved early survival of molluscs: Sydney rock oyster (*Saccostrea glomerata*). NSW Fisheries Final Report Series: 29. Nelson Bay. 63 pp.
- Heasman, M.P. 2004. Sydney rock oyster hatchery health workshop 8 – 9 August 2002, Port Stephens, NSW. NSW Fisheries Final Report Series: 61. Nelson Bay. 115 pp.

10. APPENDICES

10.1. Appendix 1 – Intellectual Property

All information brought into this project or developed during this project is public domain.

10.2. Appendix 2 – Staff

Dr Wayne O'Connor – Senior Research Scientist, Principal Investigator
NSW DPI, Port Stephens Fisheries Centre

Dr Michael Dove – Scientific Officer
NSW DPI, Port Stephens Fisheries Centre

Mr Ben Finn – Fisheries Technician
NSW DPI, Port Stephens Fisheries Centre

Mr Nick Stanning – Fisheries Technician
NSW DPI, Port Stephens Fisheries Centre

Mr Stephan O'Connor
NSW DPI, Port Stephens Fisheries Centre

Ms Lynne Foulkes
NSW DPI, Port Stephens Fisheries Centre

10.3. Handling guidelines for hatchery single seed oyster stock

10.3.1. Introduction

The following guidelines have been prepared to assist farmers not familiar with the techniques required to handle small single seed oyster spat. While these techniques may seem labour intensive and overly cautious, farmers should bear in mind that each tray may initially hold as many as 50,000 spat and a failure to secure these very small spat properly for on-growing may result in significant losses of spat from the on-growing equipment.

10.3.2. Spat supply from the nursery operator

The minimum size at which selectively bred Sydney rock oyster spat will be supplied by the nursery operator are spat retained on a 3.0 millimetre (mm) square mesh sieve, see Figure 1 below.

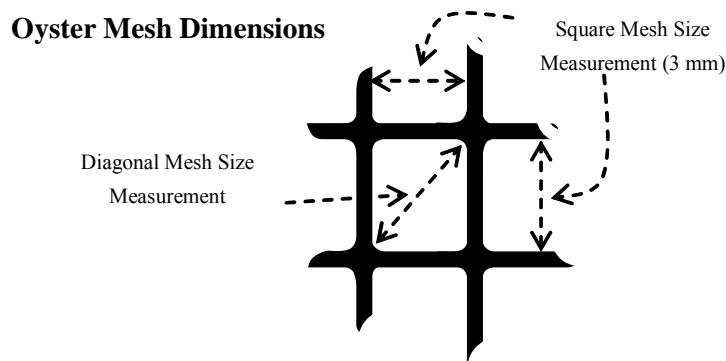

Figure 1. Descriptive dimensions of oyster mesh.

For the purposes of this document, spat dimensions are described in Figure 2 below. The smallest oyster spat retained on a 3.0 mm square mesh sieve will be approximately 5.0 mm long x 4.0 mm wide.

Individual arrangements can be made with nursery operators to supply spat at a larger size, however this may require the spat price to be re-negotiated with the nursery operator.

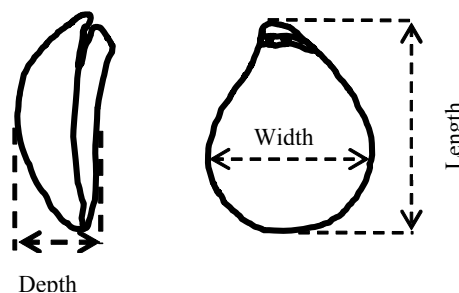

Figure 2. Descriptive dimensions of oyster spat.

10.3.3. *Handling methods*

The following handling methods are recommended for handling spat smaller than those retained on a 6.0 mm square mesh sieve.

10.3.3.1. *Sectionalised trays*

Spat retained on a 3.0 mm square mesh sieve should if possible be on-grown initially on a sectionalised tray with a plastic mesh floor of less than 1.6 mm square mesh. To ensure that small spat do not work their way between the mesh floor and the timber frame, the joint between the mesh floor and the timber frame can be sealed with a bead of silicone as shown in Figure 3.



Figure 3. Applying silicone bead to floor joint and tray surface to minimise the risk of spat loss.

Trays should be initially stocked at no more than 1 cup (250 ml) of spat per section of a 12 section sectionalised tray. An identical sectionalised tray with a floor of the same mesh should be used as a lid (mesh down) for the spat holding tray. Prior to joining the two trays together, a silicone bead should be applied to the upper surface of the spat holding tray as shown Figure 3. While the silicone bead is wet the two trays should then be fixed securely together using cable ties, or wire twists, drawn through aligned holes drilled in the timber frames as shown in Figure 4.

Trays should be initially stocked at no more than 1 cup (250 ml) of spat per section of a 12 section sectionalised tray. An identical sectionalised tray with a floor of the same mesh should be used as a lid (mesh down) for the spat holding tray. Prior to joining the two trays together, a silicone bead should be applied to the upper surface of the spat holding tray as shown Figure 3. While the silicone bead is wet the two trays should then be fixed securely together using cable ties, or wire twists, drawn through aligned holes drilled in the timber frames as shown in Figure 4.

Care should be taken to ensure that the trays do not warp and allow spat to be washed out or moved between sections of the tray.



Figure 4. Spat bearing tray and lid tray being tied together through aligned holes drilled in the tray frames.

10.3.3.2. *Bagged trays*

Standard oyster trays may also be used for on-growing spat provided that the tray is lined with snag-proof mesh bags with a stretched diagonal mesh size of less than 2.0 mm. Mesh bags must be secured (stapled) into the tray as shown in Figure 5 with the top and bottom folded over to ensure the spat cannot escape. Stapling over a piece of light cord will enable the staples to be removed with minimal damage to the mesh bag, enabling the bag to be used a number of times.



Figure 5. Mesh bags containing approximately 3 cups of spat being stapled into place on a standard 1.8 m oyster tray.

To minimise the risk of damage to the mesh spat bags and loss of spat, the trays should have a suitable plastic oyster mesh cover stapled into place as shown in Figure 6.



Figure 6. Oyster mesh cover being stapled into place to protect oyster spat mesh bags secured in place in tray.

10.3.3.3. *Stanway cylinders*

Small spat may also be on-grown in Stanway Cylinders, provided that the cylinder mesh size is less than 2.0 mm (square mesh size). Care should be taken to ensure that the cylinders seal tightly to ensure that spat cannot escape. Cylinders should be initially stocked at approximately 1 litre of spat per cylinder.



Figure 7. Stanway Cylinder with 1.6 mm mesh.

10.3.4. *Grading of spat*

After initial stocking, trays should be graded approximately every 2 weeks for the first 3 months. During this period spat should be graded by hand held sieve. Spat should be graded using 5.0 mm, 7.0 mm and 10.0 mm square mesh sieves. Spat retained on each sieve should be stocked onto trays with a mesh floor at least 2.0 mm smaller than the sieve mesh size. Spat should be stocked at the same initial stocking rate volumes. In the initial stages, spat can be expected to double in volume approximately every 7 days when grown under ideal conditions.

All care should be taken to ensure that small oyster spat are not exposed to excessive heat or be allowed to dry out during grading. Therefore, spat should always be kept shaded and away from drying winds, and should be returned to the water as soon as possible after grading.

Once spat have reached a size that is retained on a 10.0 mm square mesh sieve, they may be on-grown using normal single seed farming techniques.

10.3.5. *Selecting a nursery lease site*

When deciding on an appropriate site to locate your nursery trays you should choose a site that:

- has sufficient breeze to keep spat cool during the warmer summer months;
- does not suffer significant over-catch
- is not exposed to wind generated waves or boat wash;
- is not exposed to high levels of siltation; and
- is not exposed to fresh water inundation.

While on the nursery lease, all spat trays should be covered with shade cloth and be tightly secured to the oyster rack.

10.3.6. *Technical assistance*

Should you require any technical assistance or advice regarding the handling or on-growing of your selectively bred single seed oyster spat, please do not hesitate to contact one of the following NSW DPI staff:

- Dr Wayne O'Connor (02) 4916 3906
- Dr Michael Dove (02) 4916 3807

(NSW DPI Advisory Note – Distributed to all NSW Farmers)

10.4. Introduction to nurseries for hatchery produced oyster spat

10.4.1. Introduction

The information in this section is an introductory guideline for farmers interested in operating field nurseries for on-growing of small (0.75 mm) ex-hatchery oyster spat. It is not intended nor should be used as a manual.

10.4.2. Spat supply from the hatchery

Irrespective of the species of oyster (Sydney rock, Pacific or flat), the larvae are about 330 – 350 microns (μm , 1000 microns = 1 mm) in shell length when they settle and transform into spat (juveniles). Newly settled spat (Figure 1) are usually held in the hatchery for a week or more until they are large enough to be retained on a 500 micron sieve.



Figure 1. Newly-settled hatchery-produced Sydney rock oyster spat.

10.4.3. Apparatus

Upweller nurseries of the type illustrated in Figures 2 & 3, are one way that these spat are on-grown to a size at which they can be handled on leases by most farmers. The name upweller is derived from a system in which spat are held on a screen in a tank or trough. Seawater is pumped into each tank, which then “wells up” through the screen before passing to waste through a screened outlet into the sump. The example pictured (Figure 3), is a twin tank system with a central overflow sump.

The design and construction of the upwellers varies. Upweller screens have been made from plastic, wood or fibreglass. The example (Figure 2), is the most common in NSW and is made from sheet plastic that is welded in to a 45 cm diameter cylinder. Fine mesh is glued to the base of the cylinder and then secured with an additional ring of plastic that is heat-shrunk around the rim of the screen. An outlet (sleeve) is glued or welded through the upper wall of the screen. This sleeve serves to bayonet mount the screen to the inner wall of the tank connecting it to the sump. A small (1.5 cm) hole in the wall of the screen, opposite the outlet, is used to hold a rod or peg that braces

the screen (Figure 2). Plastic mesh secured with a cable tie or similar is placed over the outlet as a back-up screen to prevent spat being accidentally flushed from the screen.



Figure 2. 45 cm diameter upweller screen fitted with 0.35 mm mesh, with an outlet screen and a support peg.

Upweller tanks have been constructed from fibreglass, plywood or moulded plastic and are designed to hold a number of screens. The example (Figure 3) is 2.7 m long x 1.25 m wide x 0.5 m deep, with a central trough or channel 12 cm wide. This tank holds 10 screens.



Figure 3. Upwelling tank.

Flow rates of water through the screens are an important consideration and vary in accordance with the numbers of spat held, the size of the spat and the amount of suitable food in the water. It is impossible to predict in advance what will be required, however, as a rule of thumb we allow 20 L/minute for each 45 cm upweller screen. Flows however should not be strong enough to lift the spat off the screen into the water column as they will clog the outlet and cause the screen to overflow.

10.4.4. Stocking upweller screens

Stocking densities for the screens vary with the size of the spat. Spat from the hatchery are usually large enough to be retained on at least a 500 micron mesh sieve, however, for safety these spat are placed on a 350 micron screen in the nursery. We stock 250,000 spat (120 ml) on each 350 micron screen. The spat remain on the 350 micron screen until they are large enough to be retained on 670 micron mesh, at which time they are moved to 500 micron screen. When the spat are large enough to be retained on 1.25 mm mesh, they are moved to 1 mm screen. As the spat grow the number of spat on each screen is reduced.

Each 10-screen upweller unit described is capable of handling batches of 750,000 to 1 million spat at a time. But this allows for differences in growth rates within each batch of spat and requires that spat are progressively removed from the system when they reach a size at which they can be transferred to the leases. This transfer is usually not attempted until the spat are at least large enough to be retained on 2 mm mesh and more often occurs when they are large enough to be retained on 3 mm mesh.

Growth is the best indicator of a good nursery and, given suitable water temperatures, the volume of newly stocked spat should increase steadily. Another rough rule of thumb is that the volume of spat should double every 7 to 10 days. If growth is slow or inconsistent, the general health of the spat should be checked and consideration should be given to either increasing the flow rates to screens or spreading the spat into additional screens at the same flow rate per screen.

10.4.5. Maintenance

Upwellers require regular maintenance, particularly when 350 and 500 micron screens are in use as they are very fine and clog easily. Generally, the tanks are drained and the spat are rinsed twice daily to remove any faeces, silt and debris. Spat also require regular grading to keep the size of spat on each screen as uniform as possible. Grading is achieved by gently wet-sieving the spat through different sized screens. The frequency with which grading takes place will be a function of the rate at which they are growing but generally occurs once every one to two weeks.

Grading is also an ideal time to record the volumes of spat within the screens. This is done by placing the spat into measuring cylinders with some seawater and gently tapping the cylinder until the spat settle down to a steady packed volume. The volume is recorded and provides both an indication of the growth since their last volume measurement as well as allowing the nursery operator to make an estimate of the numbers of spat.

10.4.6. Costs

Setting up an upweller system requires a pump and the plumbing necessary to supply water to and remove wastewater from the tank. Upweller screens can be purchased locally and currently cost approximately \$150 each. Several existing nursery operators have chosen to build their own screens, which cut costs considerably. To set up a single unit will require 3-4 x 350 micron screens, 4-6 x 500 micron screens and 6-8 1000 micron screens. A 670 micron and 1250 micron grading screen would be valuable, along with either a 2mm or 3mm grading screen – depending on the size at which spat are to be removed from the system to go to the estuary.

As with screens, some nursery operators have chosen to build their own tanks, otherwise the cost will depend on the type of tank chosen and can vary from \$500 to \$1500 for a bare tank without fittings.

Providing the upweller unit with a cover helps to prevent the growth of algal fouling in the system and helps to keep out other wind-borne contaminants (leaves and dust). The cover can be as simple as a sheet of shade mesh.

10.4.7. *Selecting a nursery site*

There are no guarantees for a good nursery site, but when deciding on a site some questions to consider are:

- In your experience as an oyster farmer would you choose this site to grow small spat?
- Does the site have the necessary infrastructure (power and water)?
- You may have to visit the site twice a day, every day. Is the site readily accessible and will it be comfortable to work there in all weather conditions?
- Is the site prone to high levels of silt or frequently prone to freshwater inundation?
- If prone to freshwater inundation is it sufficiently deep and stratified to reliably access deeper, higher salinity water during such occasions?
- Is the site suitably secure?
- Spat growth is highly temperature dependent. Warmer sites will extend the season over which the nursery can operate.

10.4.8. *Technical assistance*

Should you require any technical assistance or advice regarding the handling or on-growing of hatchery spat, please do not hesitate to contact one of the following DPI staff:

- Dr Wayne O'Connor (02) 4916 3906
- Dr Michael Dove (02) 4916 3807

There are now several well-run nurseries in NSW and if you cannot visit the Port Stephens Fisheries Centre, we strongly recommend visiting a nursery near you to see the systems first hand, discuss their operation and appreciate what is involved.

(NSW DPI Advisory Note – Distributed to all NSW nursery operators)

10.5. Procedures for routine oyster spat sampling

10.5.1. Introduction

Procedures to collect and fix spat or juvenile oysters for disease investigation are listed below. Demand for hatchery-produced oyster spat is increasing as more growers move from naturally caught spat to faster growing or disease resistant stock. Currently, there are more than a dozen nursery operators in New South Wales receiving spat from a number of different bivalve hatcheries, including interstate hatcheries under permits issued by NSW DPI.

Spat mortalities can occur, particularly at the time of transport to field nurseries, and are generally caused by environmental factors and/or disease. Regular sampling of spat is essential as it protects the interests of nursery operators and, more importantly, helps to detect diseases and prevent their translocation.

Spat are usually smaller than 1 mm when they are delivered from a hatchery to a nursery and are therefore very vulnerable. Hatcheries provide spat with stable food and water quality conditions. However, when spat are moved to field nurseries they are exposed to widely fluctuating and abrupt water quality changes for the first time in their lives.

10.5.1.1. The importance of regular spat sampling

Regular sampling of spat is very important. This provides nursery operators rearing hatchery spat with a record of spat health while they are in nursery systems. Should problems occur, a set of regular samples means that the cause or causes can be explored, which will assist in preventing future problems, and help guide management decisions.

It is also a permit requirement that “The permit holder shall notify the Department within 24 hours of the discovery of any declared disease, unusual disease or any significant event associated with the welfare of the fish (including oysters) on the premises”.

Water quality information is extremely useful when investigating a problem in a nursery. Regular (daily) monitoring of water quality in the nursery is therefore recommended. Physico-chemical variables to measure include: water temperature, salinity, pH and dissolved oxygen.

10.5.1.2. Sampling frequency

Spat should be sampled when received from the hatchery before being placed into the nursery system for the first time. Samples from the nursery should be collected 1 – 2 times a week. More frequent sampling will be needed if problems are noticed, for example 4 – 5 times a week. Samples should be stored in a well-ventilated, dry and cool location that is secure and cannot be accessed by children.

10.5.1.3. Identifying a problem

Some symptoms of health problems can include:

- spat cease growing,
- spat do not produce any faeces,
- shell colour lightens, or,
- spat do not close their shell when removed from water.

A microscope enables rapid assessment of spat health. A dissecting microscope that can magnify objects 20 to 40 times and is fitted with a ruler in the eyepiece (graticule) to measure the growth of spat is a very useful asset to detect problems.

Always check the volume and number of spat received from the hatchery and estimate the total number of spat removed from the nursery system. This allows comparison of the number of spat reared in the nursery against the number of spat originally ordered from the hatchery. If there is a significant shortfall there also may be a significant problem.

10.5.1.4. What to do if there is a problem

If a problem is suspected it is best to firstly, take samples of spat on all screens in the nursery system and secondly, call NSW DPI Fisheries (PH: 02 4982 1232) to speak with personnel from the bivalve hatchery for further advice.

Additional information, including methods to preserve larger oysters, can be found in the 'Collecting preserving and packaging oysters for disease testing' pamphlet available from the Animal and Plant Biosecurity Branch, NSW DPI (PH: 02 4982 1232). There are also other more detailed references that specify the methods to preserve spat listed at the end of this document.

The process of collecting and preserving a spat sample that can be used for further investigation is described below.

10.5.2. Method for spat sampling

1. Sample spat from screen.

Remove spat from the screen either by using a large pipette (Figure 1) to 'suck' the spat from the screen or gently scrape a Petri dish (Figure 1) over the screen.

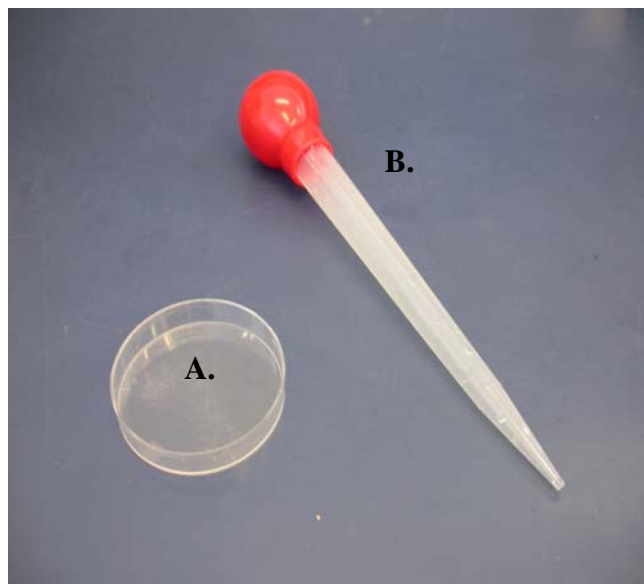

Figure 1. Petri dish (A) and pipette (B) used to sample spat off screens.

2. Empty spat into a specimen container.

These are usually 5 ml (for smaller spat) or 70 ml (for larger spat) in volume (Figure 2). It is important to ensure that spat only take up 10% of the total volume of the container so that there is enough fixative to preserve spat properly. About 30 – 50 spat, depending on size, will be needed in the sample. Figure 2 shows a good spat volume to fixative volume ratio.

3. Fill specimen container with the fixative.

Two fixatives are used to enable different diagnostic techniques. Therefore, two samples of spat need to be collected on each occasion (one sample in each fixative). The fixatives used are 10% formalin and seawater and 70% ethanol. Please refer to the following section (Formaldehyde/formalin and ethanol) for more details about handling and using these chemicals.

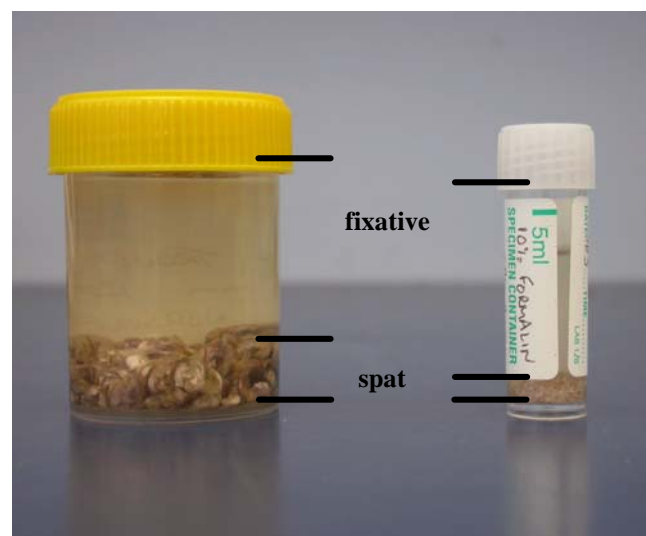

Figure 2. Example of spat samples in a 70 ml (left) and 5 ml (right) specimen container. Note the volume of spat to fixative ratio and the size difference of spat in each container.

4. Clearly label each container and store in a well-ventilated, dry, cool and secure place.

Label the container with: the species of oyster (e.g., Sydney rock oyster or Pacific oyster); the date that the sample was collected; the type of fixative (e.g., 10% formalin or 70% ethanol) and other general observations if a problem is suspected.

10.5.3. *Disease investigation*

If you have spat health concerns samples should be submitted to a Regional Veterinary Laboratory. All submissions must be accompanied with a NSW DPI Veterinary Laboratory Advice form and an Oyster Mortality History Details form. Both forms are available from NSW DPI (phone: 02 4982 1232) or the following website:

www.fisheries.nsw.gov.au/aquaculture/oysters

Oyster Packaging Guidelines are included with these forms and must be adhered to. Address samples for delivery to either:

Regional Veterinary Laboratory
Elizabeth Macarthur Agricultural Institute
Woodbridge Road
MENANGLE NSW 2568

Telephone Enquiries: 02 4640 6327
Facsimile: 02 4640 6400
Email: menangle.rvl@agric.nsw.gov.au

or

Regional Veterinary Laboratory
Wollongbar Agricultural Institute
Bruxner Highway
WOLLONGBAR NSW 2477

Telephone Enquiries: 02 6626 1262
Facsimile: 02 6626 1276
Email: wollongbar.rvl@agric.nsw.gov.au

Veterinarians may not always be able to provide definitive answers as to the exact cause or causes of the problem; however, they may be able to rule out particular infectious diseases. The cost of testing ten samples is around \$200.

10.5.4. Chemical Safety and Compliance

Chemicals used to preserve spat are toxic and hazardous at varying degrees. Use of these chemicals requires adequate training and full compliance with occupational health and safety requirements. For information on the specific risks, safe handling and safety equipment for these chemicals please read the appropriate Material Safety Data Sheet available from chemical suppliers or the internet.

Contact with eyes and skin should be prevented. Do not breathe fumes, use only in a well-ventilated area and always wear suitable protective clothing. Chemicals for fixation can be obtained from aquacultural supply companies, chemical suppliers, chemists or veterinarians. The recipe for 10% formalin and seawater solution is one volume of concentrated formalin (usually supplied as 37% formaldehyde solution) to nine volumes of clean, filtered seawater.

10.5.5. Technical assistance and further information

Should you require any further technical assistance or advice regarding oyster spat health or sampling please do not hesitate to contact either Dr Wayne O'Connor or Dr Michael Dove (NSW DPI staff) on 02 4982 1232.

The following two references contain a wealth of information on methods for sampling and preserving juvenile and adult oysters:

- Elston, R.A. 1999. 'Health Management, Development and Histology of Seed Oysters.' World Aquaculture Society, Louisiana, USA. 110 pp.
- Howard, D.W., E.J. Lewis, B.J. Keller & C.S. Smith. 2004. 'Histological Techniques for Marine Bivalve Mollusks and Crustaceans.' NOAA Technical Memorandum NOS NCCOS 5: Massachusetts, USA. 97 pp.

(NSW DPI Advisory Note – Distributed to all NSW nursery operators)

10.6. Key changes to production methodology for SRO larval and spat rearing

Progressive changes to production technology for SRO spat are inevitable and have accelerated during this research program. While the independent impacts of these changes have not been quantified, collectively they have led to improvements in growth, survival and commercial viability of SRO production. The following list has been compiled to highlight some of the major changes undertaken. For further information on these changes, reference should be made to the hatchery manual or appropriate chapter within this report.

Changes	Details	Research reference
<i>Seawater supply</i>	A dedicated seawater supply point has been installed at a fixed location in Port Stephens. Seawater is now routinely filtered to 5µm before storage in tanks at the PSFC.	Hatchery manual
<i>Hatchery plumbing</i>	The hatchery seawater system has been dramatically simplified to the extent that the system can be dismantled and all points visually inspected for cleanliness. A duplicate system has been constructed so that between batches the entire supply system is dismantled and dried while a second system is used.	Hatchery manual
<i>Spawning</i>	Spawnings must occur within three temperature cycles or oysters are returned to the conditioning systems.	Hatchery manual
<i>Larval diet</i>	Late larval diets have been amended to incorporate a new algal species mix. From Day 7, <i>Chaetoceros calcitrans</i> is removed from the diet and replaced with <i>Chaetoceros Muelleri</i> .	Chapter 4.3
<i>Hatchery chemicals</i>	A review of hatchery chemicals has removed a number of cleaning agents, placed a reliance on Virkon S and changed freshwater usage.	Chapter 4.2
<i>Heaters</i>	Heaters are only used to raise the initial temperature of the incoming seawater. Heaters are not used in tanks when culturing larvae. The tank rooms are now heated to reduce water temperature fluctuations.	Chapter 4.1
<i>Epinephrine set</i>	Crushed scallop shell is no longer used as a settlement substrate for routine production of SRO spat.	Hatchery manual
<i>Set systems</i>	Spat bottle systems have been introduced for use during commercial scale production.	Chapter 4.5

Other titles in this series:**ISSN 1440-3544 (NSW Fisheries Final Report Series)**

- No. 1 Andrew, N.L., Graham, K.J., Hodgson, K.E. and Gordon, G.N.G., 1998. Changes after 20 years in relative abundance and size composition of commercial fishes caught during fishery independent surveys on SEF trawl grounds. Final Report to Fisheries Research and Development Corporation. Project No. 96/139.
- No. 2 Virgona, J.L., Deguara, K.L., Sullings, D.J., Halliday, I. and Kelly, K., 1998. Assessment of the stocks of sea mullet in New South Wales and Queensland waters. Final Report to Fisheries Research and Development Corporation. Project No. 94/024.
- No. 3 Stewart, J., Ferrell, D.J. and Andrew, N.L., 1998. Ageing Yellowtail (*Trachurus novaezelandiae*) and Blue Mackerel (*Scomber australasicus*) in New South Wales. Final Report to Fisheries Research and Development Corporation. Project No. 95/151.
- No. 4 Pethebridge, R., Lugg, A. and Harris, J., 1998. Obstructions to fish passage in New South Wales South Coast streams. Final report to Cooperative Research Centre for Freshwater Ecology. 70pp.
- No. 5 Kennelly, S.J. and Broadhurst, M.K., 1998. Development of by-catch reducing prawn-trawls and fishing practices in NSW's prawn-trawl fisheries (and incorporating an assessment of the effect of increasing mesh size in fish trawl gear). Final Report to Fisheries Research and Development Corporation. Project No. 93/180. 18pp + appendices.
- No. 6 Allan, G.L. and Rowland, S.J., 1998. Fish meal replacement in aquaculture feeds for silver perch. Final Report to Fisheries Research and Development Corporation. Project No. 93/120-03. 237pp + appendices.
- No. 7 Allan, G.L., 1998. Fish meal replacement in aquaculture feeds: subprogram administration. Final Report to Fisheries Research and Development Corporation. Project No. 93/120. 54pp + appendices.
- No. 8 Heasman, M.P., O'Connor, W.A. and O'Connor, S.J., 1998. Enhancement and farming of scallops in NSW using hatchery produced seedstock. Final Report to Fisheries Research and Development Corporation. Project No. 94/083. 146pp.
- No. 9 Nell, J.A., McMahon, G.A. and Hand, R.E., 1998. Tetraploidy induction in Sydney rock oysters. Final Report to Cooperative Research Centre for Aquaculture. Project No. D.4.2. 25pp.
- No. 10 Nell, J.A. and Maguire, G.B., 1998. Commercialisation of triploid Sydney rock and Pacific oysters. Part 1: Sydney rock oysters. Final Report to Fisheries Research and Development Corporation. Project No. 93/151. 122pp.
- No. 11 Watford, F.A. and Williams, R.J., 1998. Inventory of estuarine vegetation in Botany Bay, with special reference to changes in the distribution of seagrass. Final Report to Fishcare Australia. Project No. 97/003741. 51pp.
- No. 12 Andrew, N.L., Worthington D.G., Brett, P.A. and Bentley N., 1998. Interactions between the abalone fishery and sea urchins in New South Wales. Final Report to Fisheries Research and Development Corporation. Project No. 93/102.
- No. 13 Jackson, K.L. and Ogburn, D.M., 1999. Review of depuration and its role in shellfish quality assurance. Final Report to Fisheries Research and Development Corporation. Project No. 96/355. 77pp.
- No. 14 Fielder, D.S., Bardsley, W.J. and Allan, G.L., 1999. Enhancement of Mulloway (*Argyrosomus japonicus*) in intermittently opening lagoons. Final Report to Fisheries Research and Development Corporation. Project No. 95/148. 50pp + appendices.
- No. 15 Otway, N.M. and Macbeth, W.G., 1999. The physical effects of hauling on seagrass beds. Final Report to Fisheries Research and Development Corporation. Project No. 95/149 and 96/286. 86pp.
- No. 16 Gibbs, P., McVea, T. and Loudon, B., 1999. Utilisation of restored wetlands by fish and invertebrates. Final Report to Fisheries Research and Development Corporation. Project No. 95/150. 142pp.
- No. 17 Ogburn, D. and Ruello, N., 1999. Waterproof labelling and identification systems suitable for shellfish and other seafood and aquaculture products. Whose oyster is that? Final Report to Fisheries Research and Development Corporation. Project No. 95/360. 50pp.
- No. 18 Gray, C.A., Pease, B.C., Stringfellow, S.L., Raines, L.P. and Walford, T.R., 2000. Sampling estuarine fish species for stock assessment. Includes appendices by D.J. Ferrell, B.C. Pease, T.R. Walford, G.N.G. Gordon, C.A. Gray and G.W. Liggins. Final Report to Fisheries Research and Development Corporation. Project No. 94/042. 194pp.
- No. 19 Otway, N.M. and Parker, P.C., 2000. The biology, ecology, distribution, abundance and identification of marine protected areas for the conservation of threatened Grey Nurse Sharks in south east Australian waters. Final Report to Environment Australia. 101pp.
- No. 20 Allan, G.L. and Rowland, S.J., 2000. Consumer sensory evaluation of silver perch cultured in ponds on meat meal based diets. Final Report to Meat & Livestock Australia. Project No. PRCOP.009. 21pp + appendices.
- No. 21 Kennelly, S.J. and Scandol, J. P., 2000. Relative abundances of spanner crabs and the development of a population model for managing the NSW spanner crab fishery. Final Report to Fisheries Research and Development Corporation. Project No. 96/135. 43pp + appendices.
- No. 22 Williams, R.J., Watford, F.A. and Balashov, V., 2000. Kooragang Wetland Rehabilitation Project: History of changes to estuarine wetlands of the lower Hunter River. Final Report to Kooragang Wetland Rehabilitation Project Steering Committee. 82pp.

- No. 23 Survey Development Working Group, 2000. Development of the National Recreational and Indigenous Fishing Survey. Final Report to Fisheries Research and Development Corporation. Project No. 98/169. (Volume 1 – 36pp + Volume 2 – attachments).
- No.24 Rowling, K.R and Raines, L.P., 2000. Description of the biology and an assessment of the fishery of Silver Trevally *Pseudocaranx dentex* off New South Wales. Final Report to Fisheries Research and Development Corporation. Project No. 97/125. 69pp.
- No. 25 Allan, G.L., Jantrarotai, W., Rowland, S., Kosuturak, P. and Booth, M., 2000. Replacing fishmeal in aquaculture diets. Final Report to the Australian Centre for International Agricultural Research. Project No. 9207. 13pp.
- No. 26 Gehrke, P.C., Gilligan, D.M. and Barwick, M., 2001. Fish communities and migration in the Shoalhaven River – Before construction of a fishway. Final Report to Sydney Catchment Authority. 126pp.
- No. 27 Rowling, K.R. and Makin, D.L., 2001. Monitoring of the fishery for Gemfish *Rexea solandri*, 1996 to 2000. Final Report to the Australian Fisheries Management Authority. 44pp.
- No. 28 Otway, N.M., 1999. Identification of candidate sites for declaration of aquatic reserves for the conservation of rocky intertidal communities in the Hawkesbury Shelf and Batemans Shelf Bioregions. Final Report to Environment Australia for the Marine Protected Areas Program. Project No. OR22. 88pp.
- No. 29 Heasman, M.P., Goard, L., Diemar, J. and Callinan, R., 2000. Improved Early Survival of Molluscs: Sydney Rock Oyster (*Saccostrea glomerata*). Final report to the Aquaculture Cooperative Research Centre. Project No. A.2.1. 63pp.
- No. 30 Allan, G.L., Dignam, A and Fielder, S., 2001. Developing Commercial Inland Saline Aquaculture in Australia: Part 1. R&D Plan. Final Report to Fisheries Research and Development Corporation. Project No. 1998/335.
- No. 31 Allan, G.L., Banens, B. and Fielder, S., 2001. Developing Commercial Inland Saline Aquaculture in Australia: Part 2. Resource Inventory and Assessment. Final report to Fisheries Research and Development Corporation. Project No. 1998/335. 33pp.
- No. 32 Bruce, A., Grown, I. and Gehrke, P., 2001. Woronora River Macquarie Perch Survey. Final report to Sydney Catchment Authority, April 2001. 116pp.
- No. 33 Morris, S.A., Pollard, D.A., Gehrke, P.C. and Pogonoski, J.J., 2001. Threatened and Potentially Threatened Freshwater Fishes of Coastal New South Wales and the Murray-Darling Basin. Report to Fisheries Action Program and World Wide Fund for Nature. Project No. AA 0959.98. 177pp.
- No. 34 Heasman, M.P., Sushames, T.M., Diemar, J.A., O'Connor, W.A. and Foulkes, L.A., 2001. Production of Microalgal Concentrates for Aquaculture Part 2: Development and Evaluation of Harvesting, Preservation, Storage and Feeding Technology. Final Report to Fisheries Research and Development Corporation. Project No. 1993/123 and 1996/342. 150pp + appendices.
- No. 35 Stewart, J. and Ferrell, D.J., 2001. Mesh selectivity in the NSW demersal trap fishery. Final Report to Fisheries Research and Development Corporation. Project No. 1998/138. 86pp.
- No. 36 Stewart, J., Ferrell, D.J., van der Walt, B., Johnson, D. and Lowry, M., 2001. Assessment of length and age composition of commercial kingfish landings. Final Report to Fisheries Research and Development Corporation. Project No. 1997/126. 49pp.
- No. 37 Gray, C.A. and Kennelly, S.J., 2001. Development of discard-reducing gears and practices in the estuarine prawn and fish haul fisheries of NSW. Final Report to Fisheries Research and Development Corporation. Project No. 1997/207. 151pp.
- No. 38 Murphy, J.J., Lowry, M.B., Henry, G.W. and Chapman, D., 2002. The Gamefish Tournament Monitoring Program – 1993 to 2000. Final report to Australian Fisheries Management Authority. 93pp.
- No. 39 Kennelly, S.J. and McVea, T.A. (Ed), 2002. Scientific reports on the recovery of the Richmond and Macleay Rivers following fish kills in February and March 2001. 325pp.
- No. 40 Pollard, D.A. and Pethebridge, R.L., 2002. Report on Port of Botany Bay Introduced Marine Pest Species Survey. Final Report to Sydney Ports Corporation. 69pp.
- No. 41 Pollard, D.A. and Pethebridge, R.L., 2002. Report on Port Kembla Introduced Marine Pest Species Survey. Final Report to Port Kembla Port Corporation. 72pp.
- No. 42 O'Connor, W.A, Lawler, N.F. and Heasman, M.P., 2003. Trial farming the akoya pearl oyster, *Pinctada imbricata*, in Port Stephens, NSW. Final Report to Australian Radiata Pty. Ltd. 170pp.
- No. 43 Fielder, D.S. and Allan, G.L., 2003. Improving fingerling production and evaluating inland saline water culture of snapper, *Pagrus auratus*. Final Report to the Aquaculture Cooperative Research Centre. Project No. C4.2. 62pp.
- No. 44 Astles, K.L., Winstanley, R.K., Harris, J.H. and Gehrke, P.C., 2003. Experimental study of the effects of cold water pollution on native fish. A Final Report for the Regulated Rivers and Fisheries Restoration Project. 55pp.
- No. 45 Gilligan, D.M., Harris, J.H. and Mullen-Cooper, M., 2003. Monitoring changes in the Crawford River fish community following replacement of an effective fishway with a vertical-slot fishway design: Results of an eight year monitoring program. Final Report to the Cooperative Research Centre for Freshwater Ecology. 80pp.
- No. 46 Pollard, D.A. and Rankin, B.K., 2003. Port of Eden Introduced Marine Pest Species Survey. Final Report to Coasts & Clean Seas Program. 67pp.

- No. 47 Otway, N.M., Burke, A.L., Morrison, N.S. and Parker, P.C., 2003. Monitoring and identification of NSW Critical Habitat Sites for conservation of Grey Nurse Sharks. Final Report to Environment Australia. Project No. 22499. 62pp.
- No. 48 Henry, G.W. and Lyle, J.M. (Ed), 2003. The National Recreational and Indigenous Fishing Survey. Final Report to Fisheries Research and Development Corporation. Project No. 1999/158. 188 pp.
- No. 49 Nell, J.A., 2003. Selective breeding for disease resistance and fast growth in Sydney rock oysters. Final Report to Fisheries Research and Development Corporation. Project No. 1996/357. 44pp. (Also available – a CD-Rom published in March 2004 containing a collection of selected manuscripts published over the last decade in peer-reviewed journals).
- No. 50 Gilligan, D. and Schiller, S., 2003. Downstream transport of larval and juvenile fish. A final report for the Natural Resources Management Strategy. Project No. NRMS R7019. 66pp.
- No. 51 Liggins, G.W., Scandol, J.P. and Kennelly, S.J., 2003. Recruitment of Population Dynamacist. Final Report to Fisheries Research and Development Corporation. Project No. 1993/214.05. 44pp.
- No. 52 Steffe, A.S. and Chapman, J.P., 2003. A survey of daytime recreational fishing during the annual period, March 1999 to February 2000, in Lake Macquarie, New South Wales. NSW Fisheries Final Report. 124pp.
- No. 53 Barker, D. and Otway, N., 2003. Environmental assessment of zinc coated wire mesh sea cages in Botany Bay NSW. Final Report to OneSteel Limited. 36pp.
- No. 54 Growsns, I., Astles, A. and Gehrke, P., 2003. Spatial and temporal variation in composition of riverine fish communities. Final Report to Water Management Fund. Project No. SW1 part 2. 24pp.
- No. 55 Gray, C. A., Johnson, D.D., Young, D.J. and Broadhurst, M. K., 2003. Bycatch assessment of the Estuarine Commercial Gill Net Fishery in NSW. Final Report to Fisheries Research and Development Corporation. Project No. 2000/172. 58pp.
- No. 56 Worthington, D.G. and Blount, C., 2003. Research to develop and manage the sea urchin fisheries of NSW and eastern Victoria. Final Report to Fisheries Research and Development Corporation. Project No. 1999/128. 182pp.
- No. 57 Baumgartner, L.J., 2003. Fish passage through a Deelder lock on the Murrumbidgee River, Australia. NSW Fisheries Final Report. 34pp.
- No. 58 Allan, G.L., Booth, M.A., David A.J. Stone, D.A.J. and Anderson, A.J., 2004. Aquaculture Diet Development Subprogram: Ingredient Evaluation. Final Report to Fisheries Research and Development Corporation. Project No. 1996/391. 171pp.
- No. 59 Smith, D.M., Allan, G.L. and Booth, M.A., 2004. Aquaculture Diet Development Subprogram: Nutrient Requirements of Aquaculture Species. Final Report to Fisheries Research and Development Corporation. Project No. 1996/392. 220pp.
- No. 60 Barlow, C.G., Allan, G.L., Williams, K.C., Rowland, S.J. and Smith, D.M., 2004. Aquaculture Diet Development Subprogram: Diet Validation and Feeding Strategies. Final Report to Fisheries Research and Development Corporation. Project No. 1996/393. 197pp.
- No. 61 Heasman, M.H., 2004. Sydney Rock Oyster Hatchery Workshop 8 – 9 August 2002, Port Stephens, NSW. Final Report to Fisheries Research and Development Corporation. Project No. 2002/206. 115pp.
- No. 62 Heasman, M., Chick, R., Savva, N., Worthington, D., Brand, C., Gibson, P. and Diemar, J., 2004. Enhancement of populations of abalone in NSW using hatchery-produced seed. Final Report to Fisheries Research and Development Corporation. Project No. 1998/219. 269pp.
- No. 63 Otway, N.M. and Burke, A.L., 2004. Mark-recapture population estimate and movements of Grey Nurse Sharks. Final Report to Environment Australia. Project No. 30786/87. 53pp.
- No. 64 Creese, R.G., Davis, A.R. and Glasby, T.M., 2004. Eradicating and preventing the spread of the invasive alga *Caulerpa taxifolia* in NSW. Final Report to the Natural Heritage Trust's Coasts and Clean Seas Introduced Marine Pests Program. Project No. 35593. 110pp.
- No. 65 Baumgartner, L.J., 2004. The effects of Balranald Weir on spatial and temporal distributions of lower Murrumbidgee River fish assemblages. Final Report to the Department of Agriculture, Fisheries & Forestry – Australia (National Heritage Trust MD2001 Fishrehab Program). 30pp.
- No. 66 Heasman, M., Diggles, B.K., Hurwood, D., Mather, P., Pirozzi, I. and Dworjanyan, S., 2004. Paving the way for continued rapid development of the flat (angasi) oyster (*Ostrea angasi*) farming in New South Wales. Final Report to the Department of Transport & Regional Services. Project No. NT002/0195. 40pp.

ISSN 1449-9967 (NSW Department of Primary Industries – Fisheries Final Report Series)

- No. 67 Kroon, F.J., Bruce, A.M., Housefield, G.P. and Creese, R.G., 2004. Coastal floodplain management in eastern Australia: barriers to fish and invertebrate recruitment in acid sulphate soil catchments. Final Report to Fisheries Research and Development Corporation. Project No. 1998/215. 212pp.
- No. 68 Walsh, S., Copeland, C. and Westlake, M., 2004. Major fish kills in the northern rivers of NSW in 2001: Causes, Impacts & Responses. NSW Department of Primary Industries – Fisheries Final Report. 55pp.
- No. 69 Pease, B.C. (Ed), 2004. Description of the biology and an assessment of the fishery for adult longfinned eels in NSW. Final Report to Fisheries Research and Development Corporation. Project No. 1998/127. 168pp.

- No. 70 West, G., Williams, R.J. and Laird, R., 2004. Distribution of estuarine vegetation in the Parramatta River and Sydney Harbour, 2000. Final Report to NSW Maritime and the Australian Maritime Safety Authority. 37pp.
- No. 71 Broadhurst, M.K., Macbeth, W.G. and Wooden, M.E.L., 2005. Reducing the discarding of small prawns in NSW's commercial and recreational prawn fisheries. Final Report to the Fisheries Research & Development Corporation. Project No. 2001/031. NSW Department of Primary Industries – Fisheries Final Report Series No. 71. 202pp.
- No. 72. Graham, K.J., Lowry, M.B. and Walford, T.R., 2005. Carp in NSW: Assessment of distribution, fishery and fishing methods. NSW Department of Primary Industries – Fisheries Final Report Series No. 72. 88pp.
- No. 73 Stewart, J., Hughes, J.M., Gray, C.A. and Walsh, C., 2005. Life history, reproductive biology, habitat use and fishery status of eastern sea garfish (*Hyporhamphus australis*) and river garfish (*H. regularis ardelio*) in NSW waters. Final report on the Fisheries Research & Development Corporation Project No. 2001/027. 180pp.
- No. 74 Grouns, I. and Gehrke, P., 2005. Integrated Monitoring of Environmental Flows: Assessment of predictive modelling for river flows and fish. NSW Department of Primary Industries – Fisheries Final Report Series No. 74. 33pp.
- No. 75 Gilligan, D., 2005. Fish communities of the Murrumbidgee catchment: Status and trends. Final report to the Murrumbidgee Catchment Management Authority. Project No. BG4_03. 138pp.
- No. 76 Ferrell, D.J., 2005. Biological information for appropriate management of endemic fish species at Lord Howe Island. NSW Department of Primary Industries – Fisheries Final Report Series No. 76. 18 pp.
- No. 77 Gilligan, D., Gehrke, P. and Schiller, C., 2005. Testing methods and ecological consequences of large-scale removal of common carp. Final report to the Water Management Fund – Programs MFW6 and MUR5. 46pp.
- No. 78 Boys, C.A., Esslemont, G. and Thoms, M.C., 2005. Fish habitat and protection in the Barwon-Darling and Paroo Rivers. Final report to the Department of Agriculture, Fisheries and Forestry – Australia (AFFA). 118pp.
- No. 79 Steffe, A.S., Murphy, J.J., Chapman, D.J. and Gray, C.C., 2005. An assessment of changes in the daytime recreational fishery of Lake Macquarie following the establishment of a 'Recreational Fishing Haven'. NSW Department of Primary Industries – Fisheries Final Report Series No. 79. 103pp.
- No. 80 Gannassin, C. and Gibbs, P., 2005. Broad-Scale Interactions Between Fishing and Mammals, Reptiles and Birds in NSW Marine Waters. Final Report for a project undertaken for the NSW Biodiversity Strategy. NSW Department of Primary Industries – Fisheries Final Report Series No. 80. 171pp.
- No. 81 Steffe, A.S., Murphy, J.J., Chapman, D.J., Barrett, G.P. and Gray, C.A., 2005. An assessment of changes in the daytime, boat-based, recreational fishery of the Tuross Lake estuary following the establishment of a 'Recreational Fishing Haven'. NSW Department of Primary Industries – Fisheries Final Report Series No. 81. 70pp.
- No. 82 Silberschnieder, V. and Gray, C.A., 2005. Arresting the decline of the commercial and recreational fisheries for mulloway (*Argyrosomus japonicus*). Final report on the Fisheries Research & Development Corporation Project No. 2001/027. 71pp.
- No. 83 Gilligan, D., 2005. Fish communities of the Lower Murray-Darling catchment: Status and trends. Final report to the Lower Murray Darling Catchment Management Authority. Project No. MD 005.03. 106pp.
- No. 84 Baumgartner, L.J., Reynoldson, N., Cameron, L. and Stanger, J., 2006. Assessment of a Dual-frequency Identification Sonar (DIDSON) for application in fish migration studies. NSW Department of Primary Industries – Fisheries Final Report Series No. 84. 33pp.
- No. 85 Park, T., 2006. FishCare Volunteer Program Angling Survey: Summary of data collected and recommendations. NSW Department of Primary Industries – Fisheries Final Report Series No. 85. 41pp.
- No. 86 Baumgartner, T., 2006. A preliminary assessment of fish passage through a Denil fishway on the Edward River, Australia. Final report to the Lower Murray Darling Catchment Management Authority, Project No. MD524. 23pp.
- No. 87 Stewart, J., 2007. Observer study in the Estuary General sea garfish haul net fishery in NSW. NSW Department of Primary Industries – Fisheries Final Report Series No. 87. 23pp.
- No. 88 Faragher, R.A., Pogonoski, J.J., Cameron, L., Baumgartner, L. and van der Walt, B., 2007. Assessment of a stocking program: Findings and recommendations for the Snowy Lakes Trout Strategy. NSW Department of Primary Industries – Fisheries Final Report Series No. 88. 46pp.
- No. 89 Gilligan, D., Rolls, R., Merrick, J., Lintermans, M., Duncan, P. and Kohen, J., 2007. Scoping knowledge requirements for Murray crayfish (*Euastacus armatus*). Final report to the Murray Darling Basin Commission for Project No. 05/1066 NSW Department of Primary Industries – Fisheries Final Report Series No. 89. 103pp.
- No. 90 Kelleway, J., Williams, R.J. and Allen, C.B., 2007. An assessment of the saltmarsh of the Parramatta River and Sydney Harbour. Final report to NSW Maritime Authority. NSW DPI – Fisheries Final Report Series No. 90. 100pp.
- No. 91 Williams, R.J. and Thiebaud, I., 2007. An analysis of changes to aquatic habitats and adjacent land-use in the downstream portion of the Hawkesbury Nepean River over the past sixty years. Final report to the Hawkesbury-Nepean Catchment Management Authority. NSW DPI – Fisheries Final Report Series No. 91. 97pp.
- No. 92 Baumgartner, L., Reynoldson, N., Cameron, L. and Stanger, J. The effects of selected irrigation practices on fish of the Murray-Darling Basin. Final report to the Murray Darling Basin Commission for Project No. R5006. NSW Department of Primary Industries – Fisheries Final Report Series No. 92. 90pp.
- No. 93 Rowland, S.J., Landos, M., Callinan, R.B., Allan, G.L., Read, P., Mifsud, C., Nixon, M., Boyd, P. and Tally, P., 2007. Development of a health management strategy for the Silver Perch Aquaculture Industry. Final report on the

- Fisheries Research & Development Corporation, Project No. 2000/267 and 2004/089. NSW DPI – Fisheries Final Report Series No. 93. 219pp.
- No. 94 Park, T., 2007. NSW Gamefish Tournament Monitoring – Angling Research Monitoring Program. Final report to the NSW Recreational Fishing Trust. NSW DPI – Fisheries Final Report Series No. 94. 142pp.
- No. 95 Heasman, M.P., Liu, W., Goodsell, P.J., Hurwood D.A. and Allan, G.L., 2007. Development and delivery of technology for production, enhancement and aquaculture of blacklip abalone (*Haliotis rubra*) in New South Wales. Final Report to Fisheries Research and Development Corporation for Project No. 2001/33. NSW DPI – Fisheries Final Report Series No. 95. 226pp.
- No. 96 Ganassin, C. and Gibbs, P.J., 2007. A review of seagrass planting as a means of habitat compensation following loss of seagrass meadow. NSW Department of Primary Industries – Fisheries Final Report Series No. 96. 41pp.
- No. 97 Stewart, J. and Hughes, J., 2008. Determining appropriate harvest size at harvest for species shared by the commercial trap and recreational fisheries in New South Wales. Final Report to the Fisheries Research & Development Corporation for Project No. 2004/035. NSW Department of Primary Industries – Fisheries Final Report Series No. 97. 282pp.
- No. 98 West, G. and Williams, R.J., 2008. A preliminary assessment of the historical, current and future cover of seagrass in the estuary of the Parramatta River. SW Department of Primary Industries – Fisheries Final Report Series No. 98. 61pp.
- No. 99 Williams, D.L. and Scandol, J.P., 2008. Review of NSW recreational fishing tournament-based monitoring methods and datasets. NSW Department of Primary Industries – Fisheries Final Report Series No. 99. 83pp.
- No. 100 Allan, G.L., Heasman, H. and Bennison, S., 2008. Development of industrial-scale inland saline aquaculture: Coordination and communication of R&D in Australia. Final Report to the Fisheries Research & Development Corporation for Project No. 2004/241. NSW Department of Primary Industries – Fisheries Final Report Series No. 100. 245pp.
- No. 101 Gray, C.A and Barnes, L.M., 2008. Reproduction and growth of dusky flathead (*Platycephalus fuscus*) in NSW estuaries. NSW Department of Primary Industries – Fisheries Final Report Series No. 101. 26pp.
- No. 102 Graham, K.J., 2008. The Sydney inshore trawl-whiting fishery: codend selectivity and fishery characteristics. NSW Department of Primary Industries – Fisheries Final Report Series No. 102. 153pp.
- No. 103 Macbeth, W.G., Johnson, D.D. and Gray, C.A., 2008. Assessment of a 35-mm square-mesh codend and composite square-mesh panel configuration in the ocean prawn-trawl fishery of northern New South Wales. Final Report to the Northern Rivers Catchment Management Authority for Project No. IS7-8-243-06. NSW Department of Primary Industries – Fisheries Final Report Series No. 103. 104pp.
- No. 104 O'Connor, W.A., Dove, M. and Finn, B., 2008. Sydney rock oysters: Overcoming constraints to commercial scale hatchery and nursery production. Final Report to the Fisheries Research & Development Corporation for Project No. 2003/209. NSW Department of Primary Industries – Fisheries Final Report Series No. 104. 119pp.